

# 51.2V 280Ah Floor Standing Lithium Energy Storage Battery



## USER INSTRUCTION











This manual introduces 51.2V 280Ah Floor Standing Lithium Energy Storage Battery. Please read this manual before you install the battery and follow the instruction carefully during installation process. Please contact immediately for advice and clarification if you have any question.

## Catalogue

<b>1. Symbol Description</b> .....	<b>4</b>
<b>2. Safety Precautions</b> .....	<b>5</b>
2.1 Before Connecting .....	5
2.2 In Using .....	5
<b>3. Introduction</b> .....	<b>6</b>
<b>4. Product Function Description</b> .....	<b>7</b>
4.1 Dimensions .....	7
4.2 Product Specifications .....	8
4.3 Equipment interface instruction .....	9
4.4 Parallel Connection .....	11
4.5 LED Indication Function .....	12
4.6 LCD introduction .....	13
4.7 Sleep Mode .....	16
4.8 Awake Mode .....	16
<b>5. Electrical Specification</b> .....	<b>16</b>
<b>6. BMS</b> .....	<b>17</b>
6.1 BMS System Schematic Diagram .....	17
6.2 BMS Parameter .....	17
<b>7. Product Life</b> .....	<b>18</b>
<b>8. Transportation</b> .....	<b>18</b>
<b>9. Emergency Situations</b> .....	<b>18</b>
9.1 Battery Leakage .....	18
9.2 On Fire .....	18
9.3 Wet Batteries .....	18
9.4 Damaged Batteries .....	18
<b>10. Remarks</b> .....	<b>19</b>
10.1 Recycle and Disposal .....	19
<b>Parts List</b> .....	<b>19</b>
<b>Maintenance Record</b> .....	<b>20</b>
Dear user,thank you for selecting our product,Please fill in and keep the warranty card for better services. ....	20



## 1. Symbol Description

	Do not place near open fire or flammable materials.
	A potential hazard exists when the equipment is working. Wear personal protective equipment during operation.
	Warning electric shock. Power off the equipment before any operation.
	Grounding: indicate PE cable connection position.
	Do not place in areas accessible to children.
	Keep the battery away from open fire or ignition sources.
	Read the product and operation manual before operating the battery system.
	Label for Waste Electrical and Electronic Equipment (WEEE) Directive (2012/19/EU).
	The certificate label for CE.
	Recycle label.

## 2. Safety Precautions



### Alert

- 1) It is important and necessary to read the user manual carefully (and attachment) before installing or using battery. Failure to do so or to follow any instruction or warning in this document can result in electrical shock, serious injury, and death, or damage battery, potentially rendering it unusable.
- 2) When battery is stored for a long time, it is required to charge once every 6 months, and the SOC should be no less than 50%.
- 3) After battery module cannot be discharged, it needs to be recharged within 12h.
- 4) Do not connect power terminal reversely.
- 5) All power supplies must be disconnected during maintenance.
- 6) Please contact the supplier within 24 hours if there is something abnormal.
- 7) Do not use any liquid to clean the battery.
- 8) Do not expose battery to flammable or irritating chemicals or vapor.
- 9) Do not paint any part of battery, including any internal or external components.
- 10) Do not connect battery with PV solar wiring directly.
- 11) Do not install or use this product beyond provisions of the manual.
- 12) Direct or indirect damages caused by the above reasons are not covered by warranty claim.

### 2.1 Before Connecting



### Warning

- 1) Please check the external packaging condition before unpacking. If it is damaged, contact corresponding local retailer.
- 2) After unpacking, please check the products and spare parts according to spare parts list. If the product is damaged or missing, please contact your local retailer.
- 3) Connect to specified matching inverter.
- 4) Before installation, be sure to cut off the grid power and make sure battery switch is on OFF mode.
- 5) It is prohibited to connect the battery and AC power directly.
- 6) All electrical wiring must be connected in accordance with local regulations.
- 7) Please ensure that electrical performance of battery system is compatible with the equipment.
- 8) The installation onsite shall be equipped with fire-fighting facilities that meet relevant requirements, such as fire sand, dry powder fire extinguisher, etc.

### 2.2 In Using

- 1) If battery system needs to be moved or repaired, power must be cut off and battery is completely shut down.

- 2) It is prohibited to connect battery with different types of battery.
- 3) Do not connect battery to faulty inverter.
- 4) Except for personnel from Company or other authorized personnel, batteries shall not be opened, repaired or disassembled. The company shall not bear any liability or responsibility caused by violation of any safety operation or design standard, production standard, equipment safety standards or any other standards or requirements.

### 3. Introduction

This stand mode LifePo4 lithium battery belongs to one of the series of house hold energy storage products that are independently designed and developed. It has long cycle life, high safety standard BMS software protection and strong housing, exquisite looks, and easy installation, etc. It is widely used in energy storage system with off- grid inverters, on-off grid inverters and hybrid inverters.

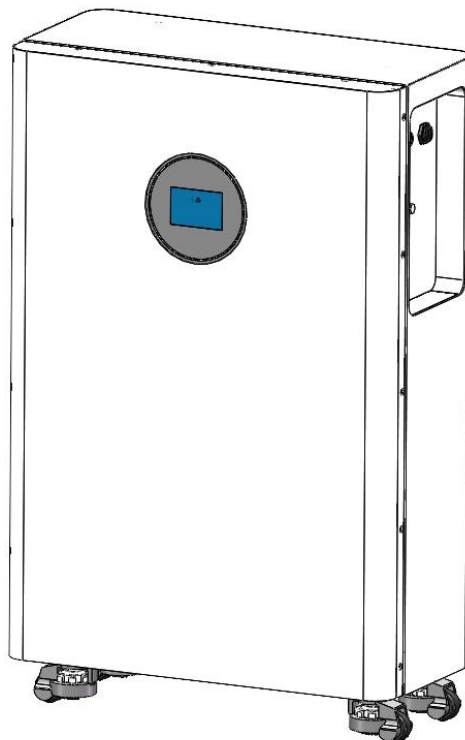

## 4. Product Function Description

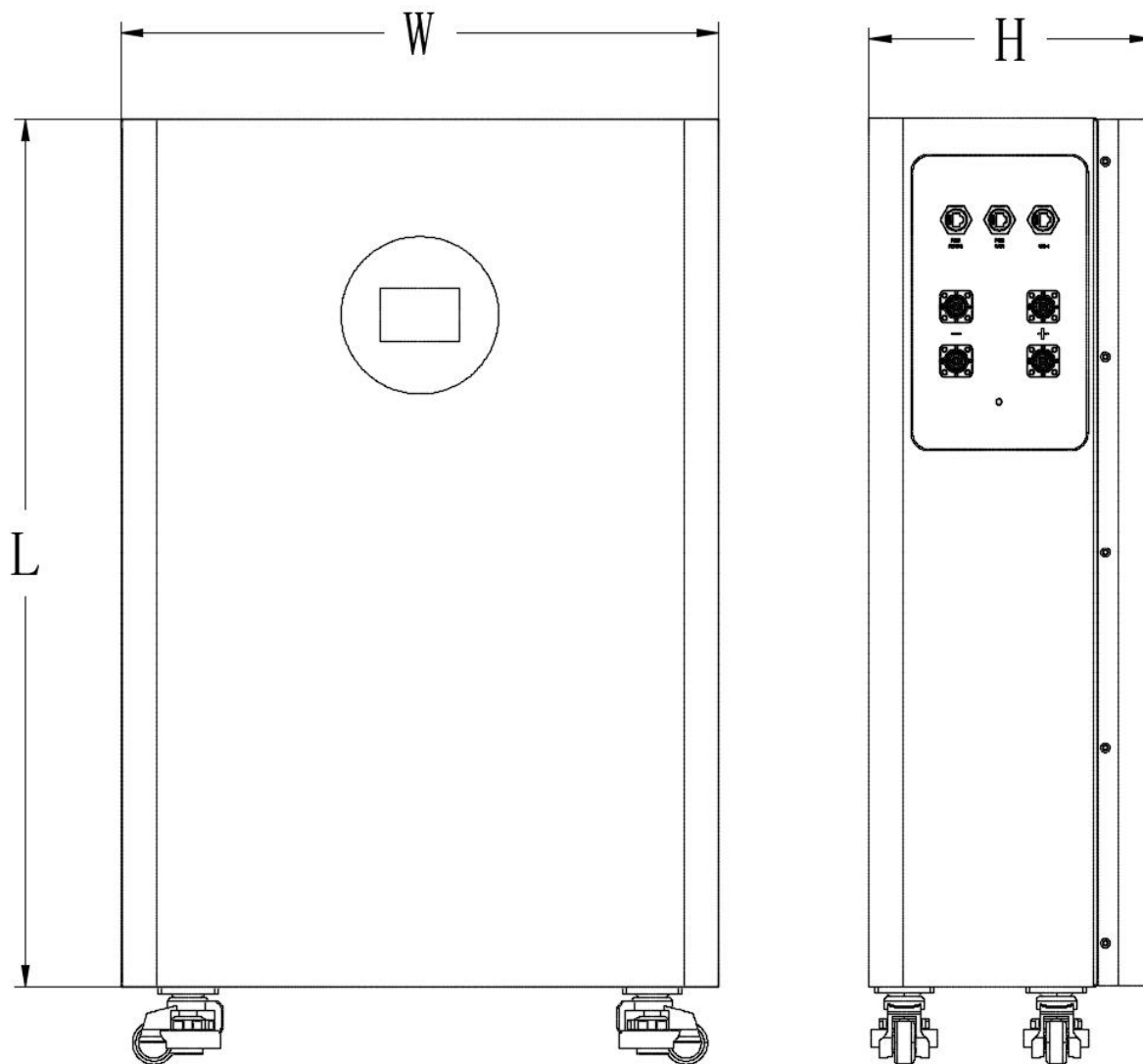

Figure 4-1

### 4.1 Dimensions

product model			
Specification	Length (L)	Width(W)	High (H)
51.2V280Ah	800mm	550mm	260mm

## 4.2 Product Specifications

Items		Condition	Specification
Nominal Capacity		Standard charge/discharge	280.0Ah
Nominal Voltage		Average	51.2V
Standard Charging Refer to 5.1		Constant current Constant voltage End current(Cut off)	100A 57.6V 1A
Charging Voltage		/	57.6V
Max. Continuous Charge Current		25±3°C	200.0A
Standard Discharging Refer to 5.2		Constant current End voltage(Cut off)	150.0A 43.2V
Max Continuous Discharge Current		25±3°C	200.0A
Nominal Energy		25±3°C	14.336kWh
Available Energy		25±3°C	12.9kWh
Operating Temperature	Charge	/	0°C ~ 55°C
	Discharge	/	-30°C ~ 55°C
Storage Temperature		/	-20°C ~ 55°C
Weight		/	~125kg



### 4.3 Equipment interface instruction

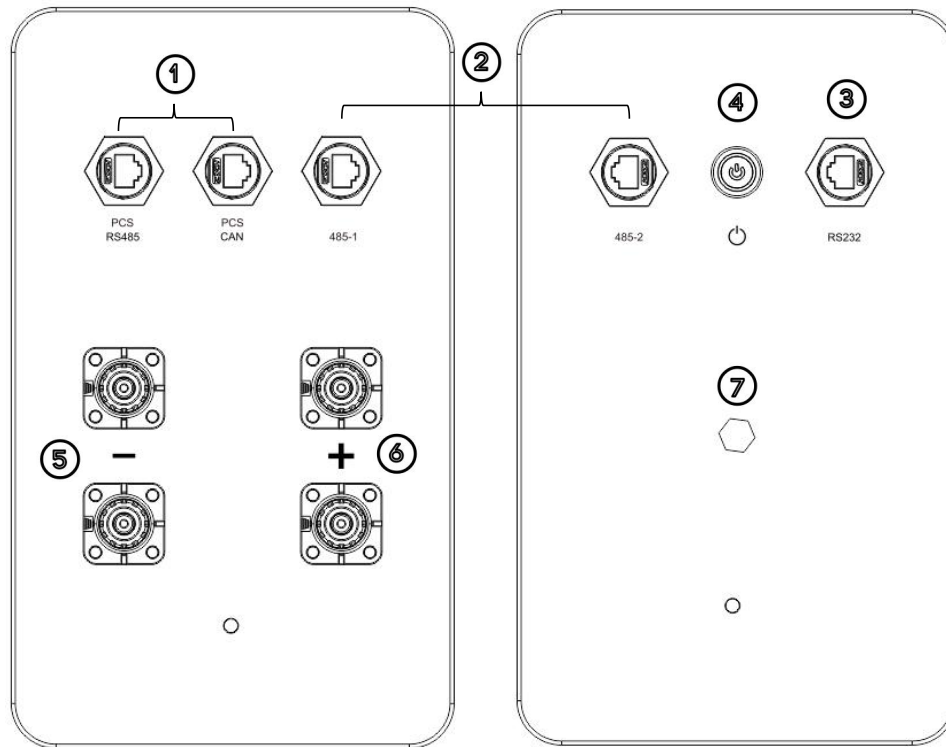
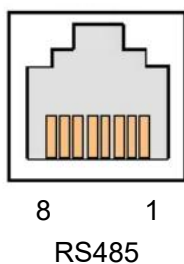

Figure 4-2

- ① **PCS: battery communication with PCS by RJ45 8P8C**
- ② **485-1/485-2: battery parallel communication**
- ③ **RS232: Communicate with the upper computer**
- ④ **Start: System start switch, Press the button BMS will works**
- ⑤ **Negative terminal: battery negative output--Connect 2AWG cable**
- ⑥ **Positive terminal: battery positive output--Connect 2AWG cable**
- ⑦ **Exhaust valve**

#### ➤ **RS485:**

The default baud rate is 9600bps, which is used for communication with the inverter. When this battery is the host, it can summarize slave data and communicate with the inverter.



Pin	Definition
1、 8	RS485-B
2、 7	RS485-A
3、 6	GND
4、 5	NC

➤ **CAN:**

The default baud rate is 500K, and this interface is used for communication with the inverter. When this battery is the host, it can summarize slave data and communicate with the inverter.

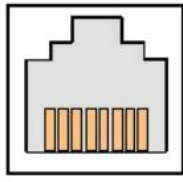

8 1  
CAN

Pin	Definition
1、3、6、7、8	NC
2	GND
4	CAN-H
5	CAN-L

➤ **Parallel RS485**

You can view the information of the PACK, with a default baud rate of 9600bps. To communicate with the monitoring device through RS485, the monitoring device serves as the host and sets the address range from 2 to 15 based on address polling data.

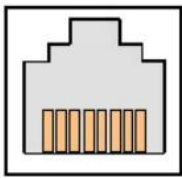

8 1  
485-1

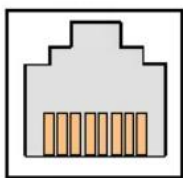

8 1  
485-2

Pin	485-1 Definition
1、8	RS485-B
2、7	RS485-A
3、6	GND
4	GND
5	UP -IN

Pin	485-2 Definition
1、8	RS485-B
2、7	RS485-A
3、6	GND
4	GND
5	DN -OP+

The parallel machine has dual RS485 interfaces. The first battery that communicates with the inverter serves as the main unit, and the 485-2 of the main unit is connected to the 485-1 of the next slave unit. The communication interfaces of each battery are connected in this staggered order, so that the main battery can read the information of each battery.

➤ **RS232**

BMS can communicate with the upper computer through RS232 interface, so that it can monitor all kinds of battery information, including battery voltage, current and temperature, working status etc. The default baud rate is 9600bps.

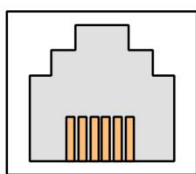

6 1  
RS232

Pin	RS232 Definition
1、2、6	NC(empty)
3	TX(computer receives data)
4	RX(computer sends data)
5	GND(ground)

#### 4.4 Parallel Connection

When Connect the batteries in parallel, connect the positive terminal and positive terminal (red colour) in parallel, and the negative terminal and negative terminal (black colour) in parallel, the max parallel quantity is 15pcs, as shown in the figure below.the parallel communication line between the battery and the inverter is connected in a staggered manner, with one end at the second 485 port and the other end at the first 485 port of the parallel battery.

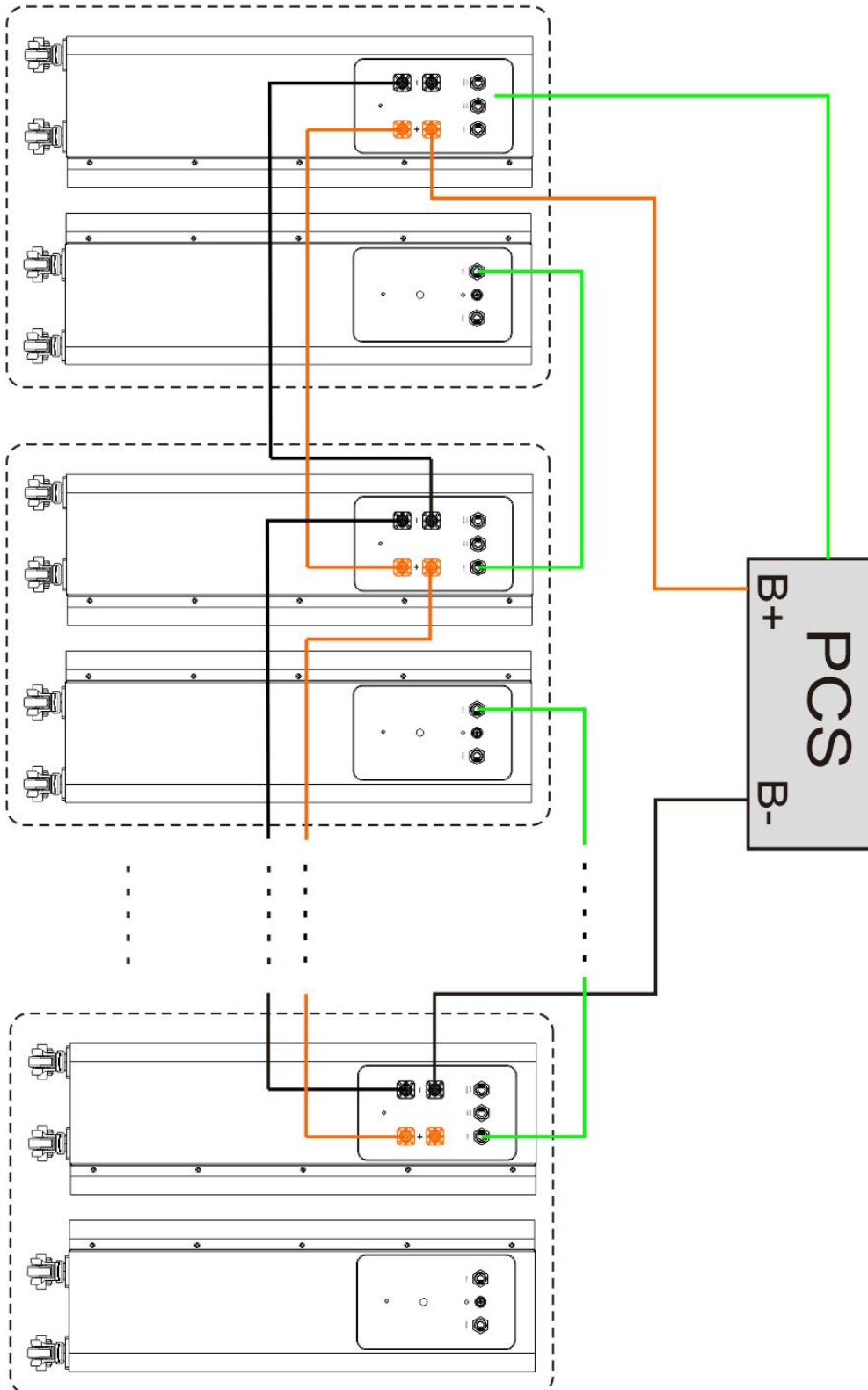

### 4.5 LED Indication Function

The current power consumption and operation status of the product are shown through LED indicator Light (See Table 1, Table 2, and Table 3 for details) Working status indication

State	Normal / Alarm / Protection	ON/OFF	RUN	ALM	SOC Indication LED						Instructions	
		●	●	●	●	●	●	●	●	●		
Power Off	Sleep	OFF	OFF	OFF	OFF	OFF	OFF	OFF	OFF	OFF	OFF	All off
Standby	Normal	ON	flash1	OFF	Indication by SOC						Standby	
	Alarm	ON	flash1	Flash3							Cell low voltage	
Charge	Normal	ON	ON	OFF	Indication by SOC (The top SOC Led Flash 2)						Maximum power LED flash(flash 2),ALM does not flash for over-charge warning	
	Alarm	ON	ON	Flash3								
	Over Charge Protection	ON	ON	OFF	ON	ON	ON	ON	ON	ON	If no mains supply, LED as standby	
	Temperature. Over-current Fault Protection	ON	OFF	ON	OFF	OFF	OFF	OFF	OFF	OFF	OFF	Close charge
Discharge	Normal	ON	Flash3	OFF	Indication by SOC							
	Alarm	ON	Flash3	Flash3								
	Under Discharge Protection	ON	OFF	OFF	OFF	OFF	OFF	OFF	OFF	OFF	OFF	Close discharge
	Temperature. Over-current. Short Circuit Fault Protection	ON	OFF	ON	OFF	OFF	OFF	OFF	OFF	OFF	OFF	Close discharge
Fault		OFF	OFF	ON	OFF	OFF	OFF	OFF	OFF	OFF	Close charge Close discharge	

## Capacity Indicator

State		Charge						Discharge					
Capacity indicator light		L6	L5	L4	L3	L2	L1	L6	L5	L4	L3	L2	L1
		●	●	●	●	●	●	●	●	●	●	●	●
electricity (%)	0 ~ 16.6%	OFF	OFF	OFF	OFF	OFF	flash 2	OFF	OFF	OFF	OFF	OFF	ON
	16.6 ~ 33.2%	OFF	OFF	OFF	OFF	flash 2	ON	OFF	OFF	OFF	OFF	ON	ON
	33.2 ~ 49.8%	OFF	OFF	OFF	flash 2	ON	ON	OFF	OFF	OFF	ON	ON	ON
	49.8 ~ 66.4%	OFF	OFF	flash 2	ON	ON	ON	OFF	OFF	ON	ON	ON	ON
	66.4 ~ 83.0%	OFF	flash 2	ON	ON	ON	ON	OFF	ON	ON	ON	ON	ON
	83.0 ~ 100%	flash 2	ON	ON	ON	ON	ON	ON	ON	ON	ON	ON	ON
Running light ●		ON						flash(flash 3)					

### LED Flashing Instructions

Flash way	ON	OFF
Flash 1	0.25S	3.75S
Flash 2	0.5S	0.5S
Flash 3	0.5S	1.5S

**Note:**

The LED indicator alarm can be enabled or disabled through the host computer. The factory default is enabled.

## 4.6 LCD introduction

### 4.6.1 Icon Description



Main menu icon, click to enter the HOME interface of the main menu



Main state icon, click to enter the Main State interface



Parallel data icon, click to enter the parallel data interface

### 4.6.2 HOME page

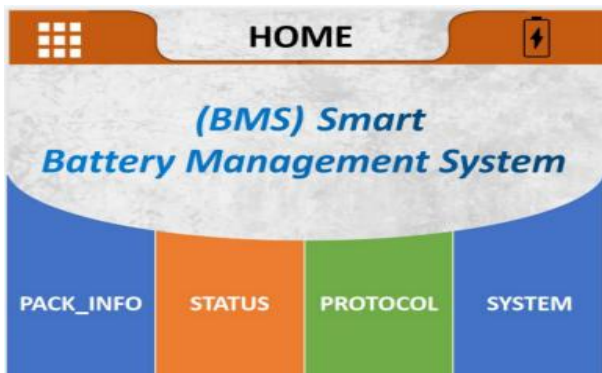

#### 4.6.3 Main State page

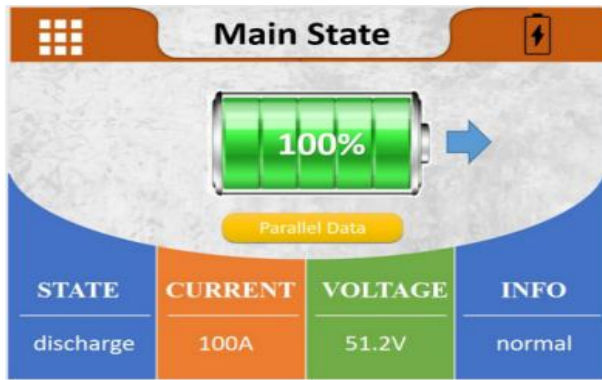

#### 4.6.4 Parallel Data page

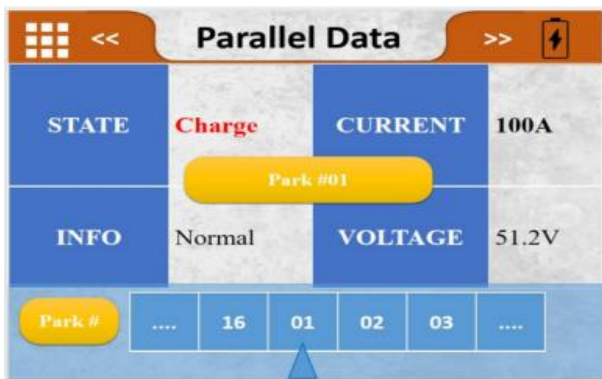

#### 4.6.5 Menu structure

- Menu
- main state page
  - SOC(Total)
  - Current
  - Voltage
  - BMS INFO
  - Warning
  - Parallel data
    - ❖ SOC(each pack)
    - ❖ Current
    - ❖ Voltage
    - ❖ BMS INFO
- HOME
  - PACK Info (pack Cell data)
    - ◆ Voltage
      - Cell01 voltage
      - Cell02 voltage
      - .....
      - Cell16 voltage
    - ◆ Temperature
      - NT1
      - NT2
      - NT3
      - NT4
      - Mos\_T
      - ENV\_T
      - .....

- BMS Status
  - ◆ Warning
    - Over Current
    - Over Voltage
    - Under Voltage
    - Over Temperature
    - Under Temperature
  - ◆ Protect
    - Over Voltage Protection
    - Under Voltage Protection
    - Short Circuit Protection
    - Over Current Protection
    - Over Temperature Protection

- PROTOCOL

- ◆ (Note: The protocol list is read from the BMS motherboard.

The following is a case study, taking into account the contents of each BMS motherboard.)Based on the list, change the protocol. The first time you need to enter the permission password, the initial password is 123456,Exit the protocol interface, permissions take effect, modify the protocol again, and verify permissions again )

- ◆ CAN

- GOOD WE PROTOCOL
- LV BMS Protocol(CAN) for Solar Inverter Family EN\_V 1.5
- PYLON PROTOCOL 2.0
- Pylon CAN bus protocol V 2.0.420211122
- SMA PROTOCOL
- SMAF SS-Connecting Bat-TI-en-20W
- GROW ATT\_PROTOCOL
- Grow ATT BMS CAN-Bus-protocol-low-voltage

- ◆ RS485

- USER\_485\_VOLTRON
- Voltaic Inverter and BMS 485 communication protocol 20200325(1)
- PYLON
- RS 485-protocol-pylon-low-voltag
- Lux power TEK Battery Protocol RS 485\_V 01

- SYSTEM

- ◆ (Language select)

- English
- 中文
- (繁体中文)

- ◆ PACK SN

- ◆ (BLUETOOTH SN)

#### 4.7 Sleep Mode

The system enters a low-power mode when any of the following conditions is met:

- 1.The monomer or overall over release protection is not removed within 30 seconds.
- 2.Press the button (3~6S) and release the button.
3. The lowest unit voltage is lower than the dormancy voltage, and the duration reaches the dormancy delay time (at the same time, meet the no communication, no protection, no equilibrium, no current).
- 4.The standby time is more than 24 hours (no communication, no charge and discharge, no city power).
5. Force the shutdown through the upper computer software. Before entering hibernation, ensure that the input is not connected with external voltage, otherwise it cannot enter the low power mode.

#### 4.8 Awake Mode

When the system is in the low power mode and meets any of the following conditions, the system will exit the low power mode and enter the normal operation mode:

- 1.Access to the charger, and the output voltage of the charger shall be greater than 48V.
- 2.Press the button (3~6S) and release the button.

### 5. Electrical Specification

( Unless there is special requirement, the test shall be done under temperature of  $25 \pm 2$ C and with relative humidity of 45~85%. )

Items	Test Condition				Standard
5.1 Standard Charge	The standard charge means charge the battery in temperature below $25 \pm 3$ °C with initial charge current of 100A(280Ah) and with constant voltage of 57.6V, then charge with constant voltage of 57.6V and with floating current taper to 1A(280Ah) cut-off (Charger should be exclusively designed for lithium battery, with an accuracy of $\pm 0.05$ V) within 6 hours.				/
5.2 Standard Discharge	After battery is charged fully in accordance with the standard and then discharge to voltage 43.2V with discharge current 150A(280Ah).The minimum gap time between charge and discharge period is 30 minutes.				Minimum Capacity $\geq 95\%$ Capacity
5.3 Cycle Life	After the completion of 0.2C charge and 30 minutes' rest, discharge to 80% DOD with constant current of 0.2C in the ( $25 \pm 3$ °C) environment, then carry out the next cycle, after 6000 cycles, rest it for 1 day and test the capacity.				Capacity $\geq 80\%$ Minimum Capacity
	Discharge current	Discharge Temperature			At -10 °C : Discharge
	0.5C	-10 °C	0 °C	25 °C	



<p>5.4 Discharge Character</p>	<p>Batteries shall be charged according to 5.1 and discharged in accordance with the above mentioned temperature. The discharge capacity shall meet the standard. Batteries shall be stored for 6~8 hours at the test temperature.</p>	<p>Capacity<math>\geq</math>50%</p> <p>At 0°C: Discharge capacity<math>\geq</math>80%</p> <p>At 25°C Discharge capacity<math>\geq</math> 100%</p> <p>At 40°C Discharge capacity<math>\geq</math> 100%</p>
--------------------------------	--	---

## 6. BMS

### 6.1 BMS System Schematic Diagram

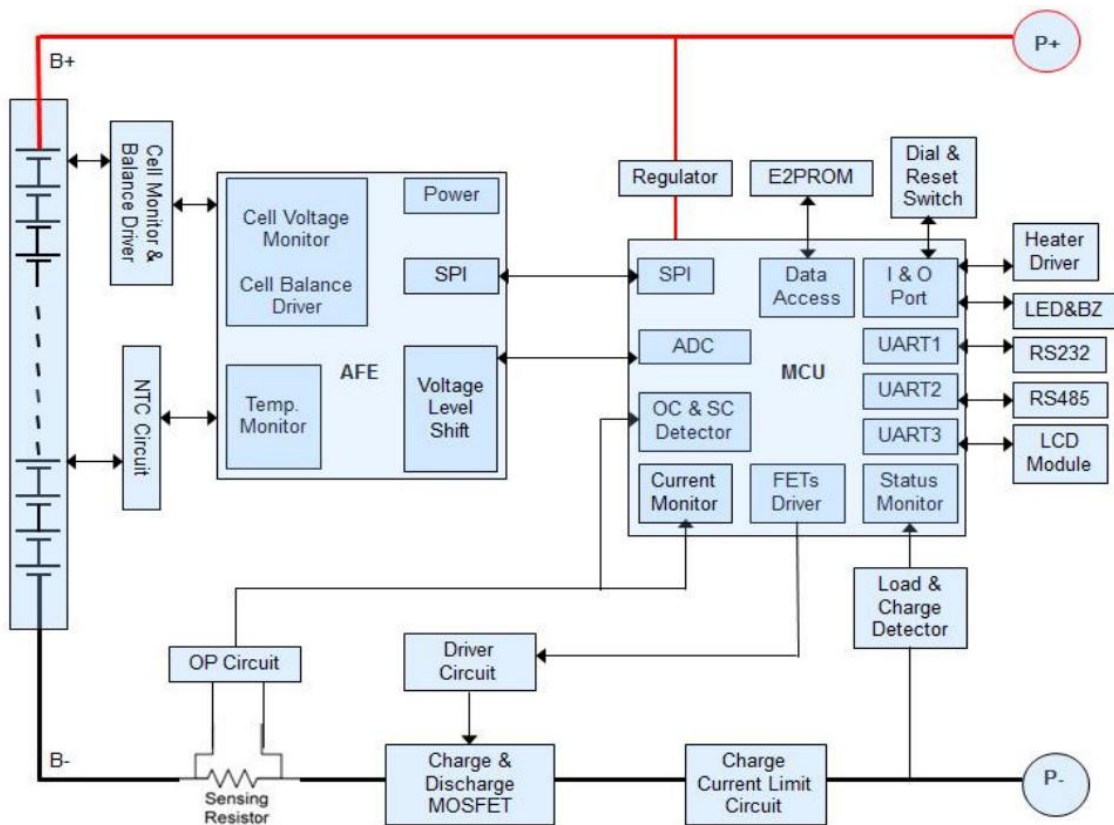

### 6.2 BMS Parameter

No.	Item		51.2V 280Ah
1	Power Consumption	Low power consumption mode	$\leq 100\mu\text{A}$
2	Over charge Protection	Over charge detection voltage	3.65V
		Over charge release voltage	3.38V
3	Over discharge protection	Over discharge detection voltage	2.7V
		Over discharge release voltage	2.95V

4	Over current protection	Charging over current detection current (detection time)	205A (1S)
		Discharging over current detection current 1 (detection time)	205A (1S)
		Discharging over current Detection current2 (detection time)	≥250A 500ms
5	Temp. Protection	Detection temperature	65± 2C
6	Balance	Balance voltage	3.5V

## 7. Product Life

The design life of this product is 10 years.

## 8. Transportation

During transportation, please keep the battery from acutely vibration, impacting, over-exposure to the sun and drenching.

## 9. Emergency Situations

### 9.1 Battery Leakage

If the battery pack leaks electrolyte, avoid contact with the leaking liquid or gas. If one is exposed to the leaked substance, immediately perform the actions described below.

- 1) Inhalation: Evacuate contaminated area and seek medical aid.
  - 2) Contact with eyes: Rinse eyes with flowing water for 15 minutes and seek medical aid.
  - 3) Contact with skin: Wash affected area thoroughly with soap water and seek medical aid.
- Ingestion: Induce vomiting and seek medical aid.

### 9.2 On Fire

**NO WATER!**

Only dry powder fire or carbon dioxide extinguisher can be used; if possible, move the battery module to a safe area before it catches fire.

### 9.3 Wet Batteries

If the module is wet or submerged in water, do not let people access it, then contact us or an authorized dealer for technical support. Cut off all power switch on inverter side.

### 9.4 Damaged Batteries

Damaged batteries are dangerous and must be handled with utmost care. They are not fit for use and may pose a danger to people or property. If the module seems to be damaged, pack it in its original container, then return it to authorized dealer.



### **Warning**

Damaged batteries may leak electrolyte or produce flammable gas.

## 10. Remarks

### 10.1 Recycle and Disposal

In case a battery (normal condition or damaged) needs disposal or needs recycling, it shall follow the local recycling regulation (Suggest Regulation (EC) N° 1013/2006 among European Union) to process, and using the best available techniques to achieve a relevant recycling efficiency.

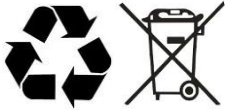

### Parts List

Item	Part Name	Description	Unit	Quantity
1	Network line	1 meters network line	PCS	1
2	Network cable	2 meters of inverter communication network cable	PCS	1
3	Positive and negative pole line	A pair of red and black 1 meters parallel positive and negative electrode line 4	PCS	1
4				
5				
6				
7				
8				
9				

## Maintenance Record

Dear user.thank you for selecting our product,Please fill in and keep the warranty card for better services.

Attn: \_\_\_\_\_ Product No.: \_\_\_\_\_

Tel: \_\_\_\_\_ E-mail: \_\_\_\_\_

Purchase Date: \_\_\_\_\_

Address: \_\_\_\_\_

Maintenance Record			
Date of repair	Content	Maintenance Personnel	Note



## Suzhou Preta Intelligence and Technology Co.,Ltd

---

Add: No..55 Shangxiang Road, Huaqiao Corporation Head Quarter Centre, Kunshan City, Suzhou City, China

Tel: 0512-36684019

Email: [info@pretapower.com](mailto:info@pretapower.com)

Web: <https://pretapower.com/>