

# Hybrid Solar Inverter

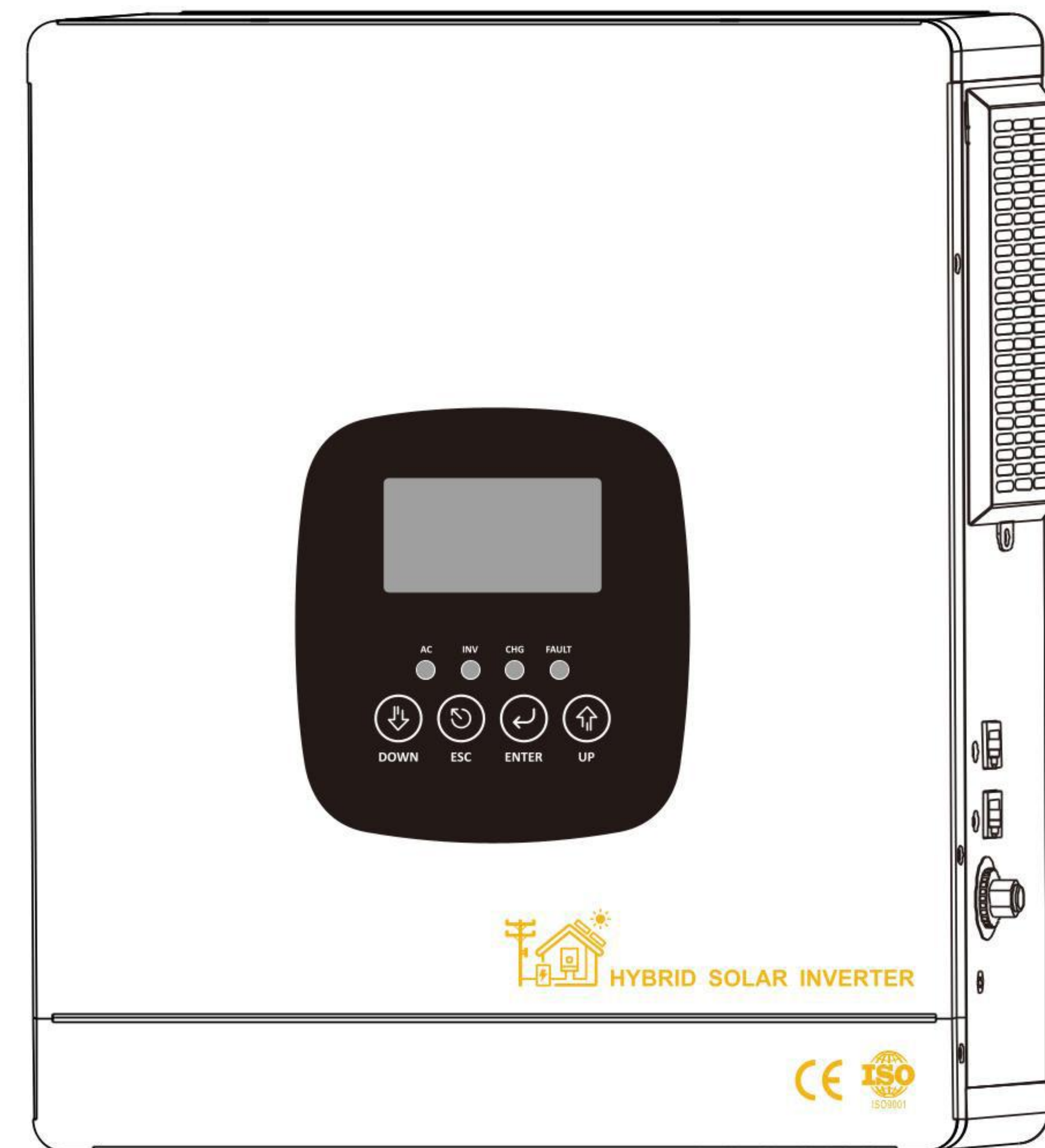

**User Manual**

# Content

1. Installation Instructions-----	2
2. Outlook/Overview of Inverter-----	9
3. Wiring -----	13
4. LCD Display-----	21
5. Error and Solution-----	35
6. Output Priority&Working Mode -----	37
7. Maintenance -----	41
8. Technical Specification-----	42
9. Appendix: 485 Communication Port -----	44
10. Appendix: WIFI/GPRS Communication Port----- (WIFI/GPRS/4G data collector is optional)	44
11. Appendix(Maintenance Record&Certificate)-----	45



## Warning

**This is A class inverter. It might cause slightly radio interference in daily life. And practical measure isrequired to take under this condition.**

### Preface

Thank you for the purchase of on/off grid hybrid solar inverter (Hereinafter referred to as inverter). Please read this manual carefully before installing and using the inverter!

### Copyright





We have been devoted to technological innovation and aims to meet the demands of its customers with better product and services. And product design and specification would be updated without prior notice. Please in kind prevail.

### Safety instructions

1.1: How to use this manual

This manual contains important information, guidelines, operation and maintenance of the product users must follow the contents of this manual.

#### Meaning of symbols in the manual:

Symbol	Description
 <b>DANGER</b>	<b>DANGER</b> indicates a hazardous situation happen, if not be voided, will result in death or serious injury
 <b>WARNING</b>	<b>WARNING</b> indicates a hazardous situation happen, if not be avoided, could result in death or serious injury
 <b>CAUTION</b>	<b>CAUTION</b> indicates a hazardous situation happen, if not be avoided, may result in minor or moderate injury
 <b>NOTICE</b>	<b>NOTICE</b> provides some tips on operation of products

1.2: Safety instructions:

This chapter contains important safety instructions. Please read and save this manual for future reference.

- Be sure to comply with local requirements and regulations when installing this inverter.
- Beware of high voltage. Before and during installation, please turn off the switch of each power source to avoid electric shock.
- In order to achieve optimal operation of this inverter, please select appropriate cable sizes and necessary protection devices in accordance with regulations.
- Do not connect or disconnect any connections while the inverter is working.
- Do not open the terminal cover when the inverter is working.
- Make sure the inverter is well grounded.
- Do not short-circuit the AC output and DC input.
- Do not disassemble the machine. For all repairs and maintenance, please send it to a professional repair center.
- Never charge a frozen battery.

### Overview





Please read the product manual carefully before installation, operation and maintenance. This manual contains important safety instructions and installation instructions. The contents of the instructions must be followed during equipment installation and maintenance.

### Who should read this manual

This manual is intended for professional electrical technicians responsible for the installation and commissioning of inverters in photovoltaic power generation systems.

## Symbols used in this manual

In order to ensure the personal and property safety of users when using solar inverters, as well as efficient use of this product, the manual provides relevant safe operation information and uses corresponding symbols to highlight it. This emphasized information must be fully understood and absolutely adhered to to avoid personal injury and property damage. The symbols used in this manual are listed below.

 <b>DANGER</b>	" <b>DANGER</b> " indicates a highly potential hazard that, if not be avoided, will result in personal injury or death.
 <b>WARNING</b>	" <b>WARNING</b> " indicates a moderately potentially hazardous hazard happened, if not be avoided, will result in personal injury or death.
 <b>CAUTION</b>	" <b>CAUTION</b> " indicates a mild potential hazard that, if not be avoided, will result in moderate or minor personal injury.
 <b>NOTE</b>	" <b>NOTE</b> " indicates a mild potential hazard that, if not be avoided, may result in moderate or minor personal injury.
 <b>TIPS</b>	" <b>TIPS</b> " are additional information in the manual, which emphasize and supplement the content. They may also provide tips or tricks for optimizing the use of the product, which can help you solve a certain problem or save time.

## Installation Instructions

### 1-1: Open-package inspection

After opening the package, please check random accessories, including user manual (contains conformity certificate and warranty card) and accessories for optional functions. And check whether the inverter is still kept well after transportation, if find any broken or component missing, do not turn on the machine, feedback to the carrier and distributor.

#### Note:

- Please keep the packing box and packing material, can be used for next delivery if needed.
- This series of product is very heavy (check appendix as reference), please handle with care when carrying.

### 1-2: Installation notice

- 1) Install in an area of well ventilated, free of water, burning gas and corrodent.
- 2) The installation method of the machine is wall-mounted, and the air inlet of the fan and the air outlet on the side and top of the box should be kept unobstructed.
- 3) Around environment temperature should remain 0–40 centigrade.
- 4) If disassembling and operate under low temperature environment, may happen water condense, only can work till thorough dry of machine inside and outside, otherwise will be shock risk.
- 5) If the machine is placed for a long time, it should be confirmed that the machine is completely dry and no corrosion can be installed and used.

### 1-3: Installation steps

#### 1) Environmental requirements

Open the package and place the inverter in a reasonable working environment. Refer to the “Installation Precautions” for specific requirements.

#### 2) Wire diameter selection

Use a cable with a suitable wire diameter, which can not be lower than the national safety standard. The general wire diameter is selected according to the current density of not more than 5A/mm<sup>2</sup>, and the length of the connecting wire is minimized to reduce the loss.

#### 3) Connect the battery

Determine the appropriate number of battery cells according to the rated battery voltage of the inverter. Connect the battery cable to a circuit breaker that meets the breaking capacity, and then connect it to the BATTERY terminal of the inverter. Note that the positive and negative poles cannot be reversed. Otherwise, the product may be damaged.

#### 4) Connect load

First turn off all loads, connect the AC load to the AC output of the inverter, and ensure that the load power is lower than the rated power of the inverter.

#### 5) Connect PV

Connect the PV cable to the circuit breaker that meets the breaking capacity first, and then connect it to the PV input end of the inverter. The open circuit voltage/short-circuit current of the PV array should be lower than the maximum PV input voltage/current of the inverter. Note that its positive and negative poles cannot be reversed.

#### 6) Connect mains power

Connect the mains power input cable to the circuit breaker that meets the breaking capacity first, and then connect it to the AC input end of the inverter. Note that its phase and polarity should not be reversed.

#### 7) Selection of circuit breaker

- a. The circuit breaker at the battery end shall be a DC circuit breaker, and the working voltage of the circuit breaker shall be greater than the rated voltage of the battery; The circuit breaker at the PV input end shall be a DC circuit breaker whose working voltage shall be greater than the voltage of the PV array. The circuit breaker at the AC input end shall be an AC circuit breaker whose working voltage shall be greater than the rated voltage of the mains supply.
- b. The rated current of the circuit breaker should be about 1.5 times of the maximum current when the inverter is working.

#### Note:

- Before connecting the load to the machine, please turn to the loads firstly.
- This product can only protect high-voltage surges with low energy. In areas with high lighting output, it is recommended to install lightning protection devices outside the mains input terminals and PV input terminals.
- To ensure the personal safety of the user and ensure the correct use of the product, please confirm that it is properly grounded before starting the machine.
- If user want to load an inductive load such as a motor or a laser printer which operating power is too large, the inverter rated capacity should be selected according to its peak power . The load starting power is generally 2 to 3 times of its rated power.

**1-4: Placement:**

Please leave 100mm of space for each side of inverter to keep good air circulation.

**(Only suitable for installation on concrete or other non-combustible surfaces with objects with appropriate load-bearing capacity, and ensure that the inverter is placed vertically. A suitable place for installing electrical equipment should be selected to ensure sufficient fire escape space for repairs in the event of a failure. Maintain Proper ventilation conditions to ensure sufficient air circulation required for cooling, air humidity < 90% during assembly.)**

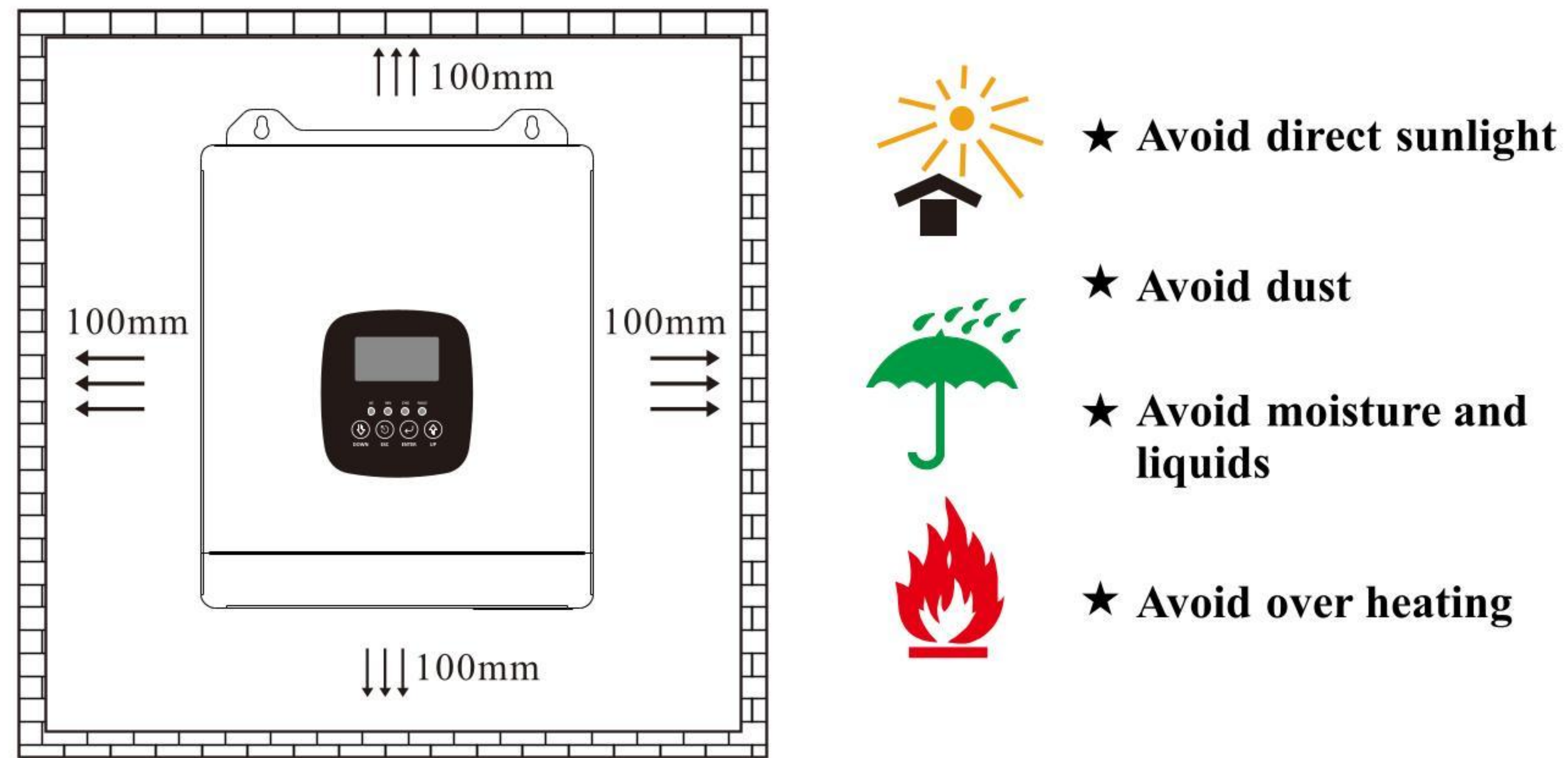

**1-5 Installation size & Wall mounted installation**

1) Installation size

a. 3.3KW

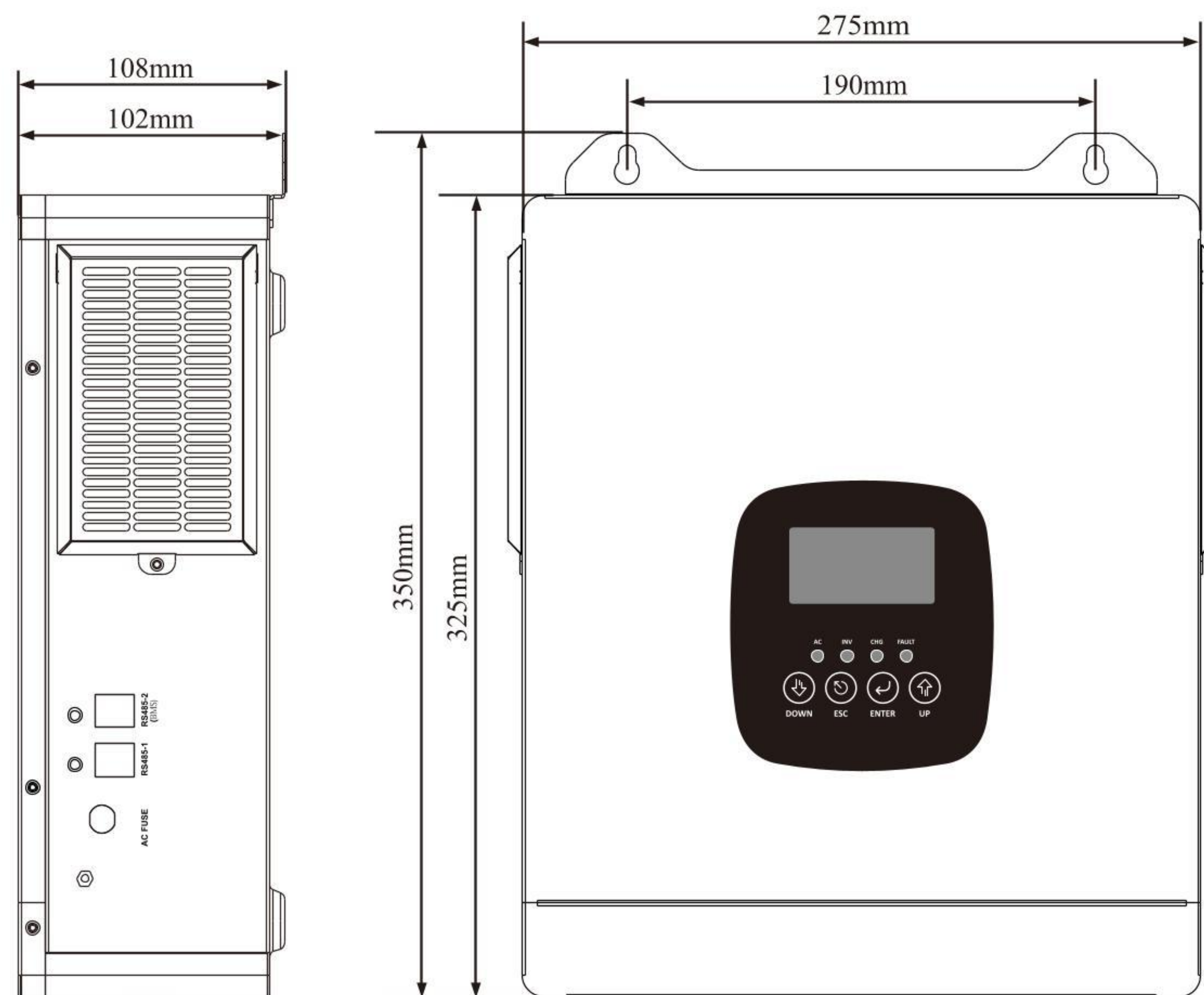

b. 4.3KW

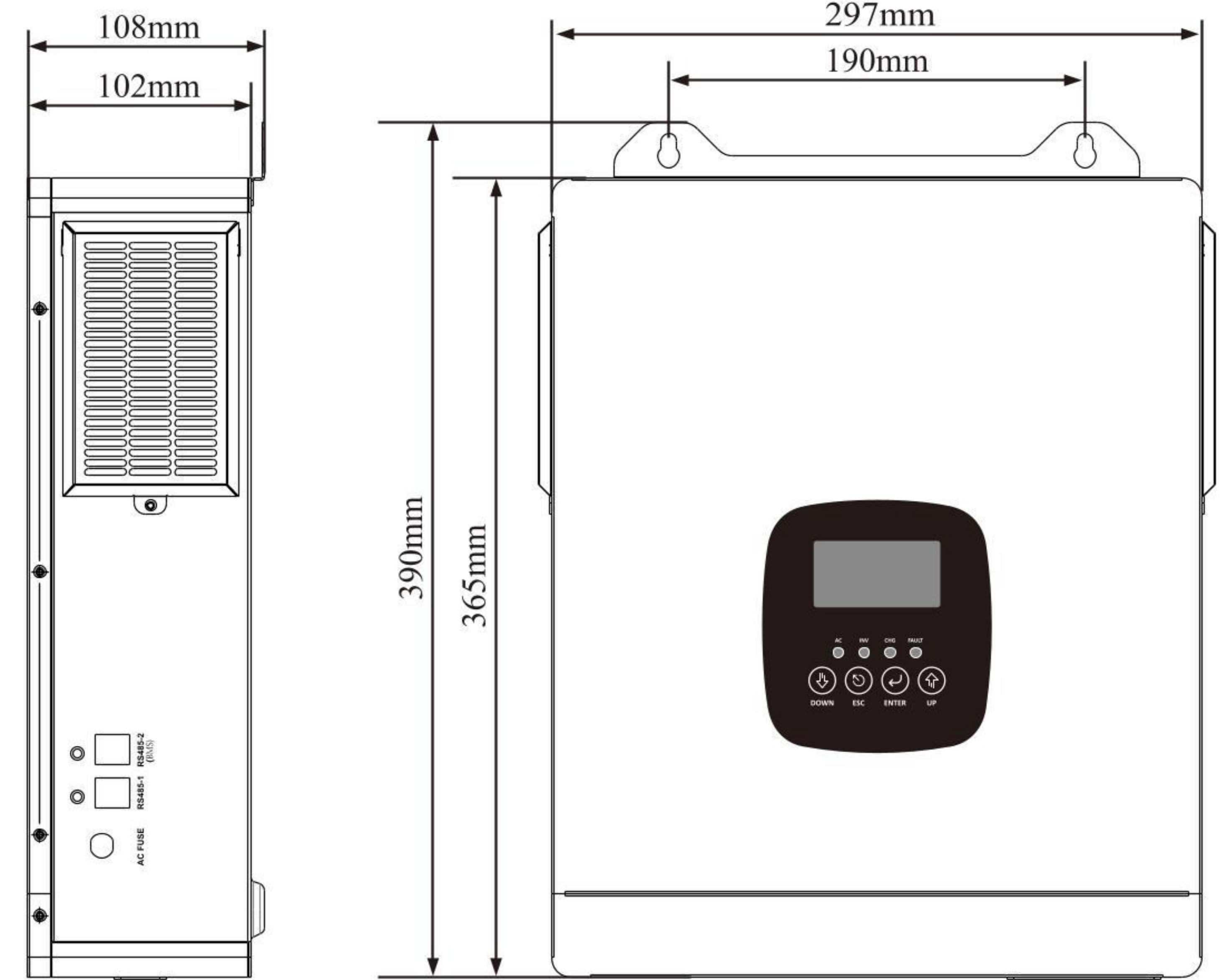

c. 6.3KW

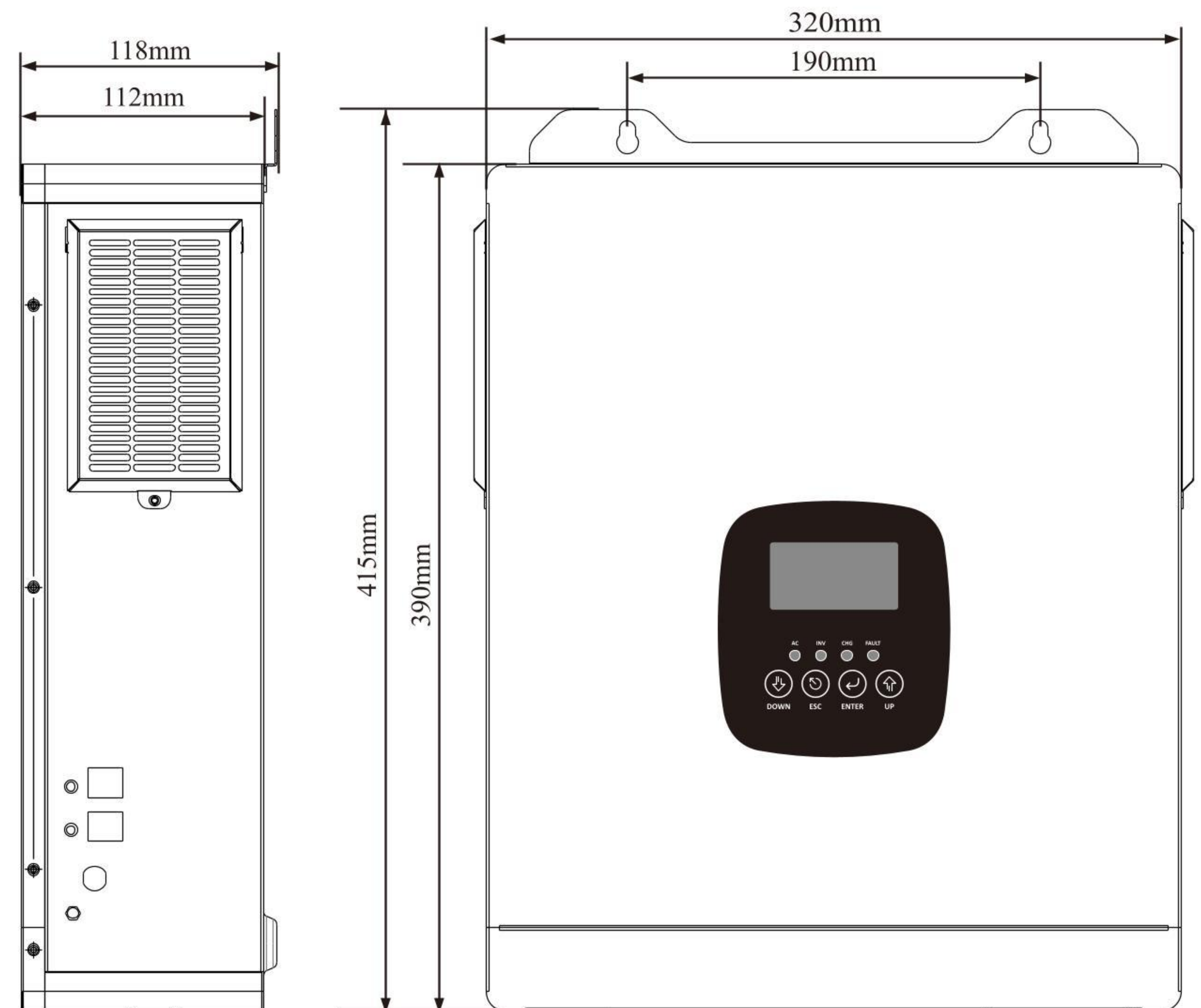

d. 8.3KW

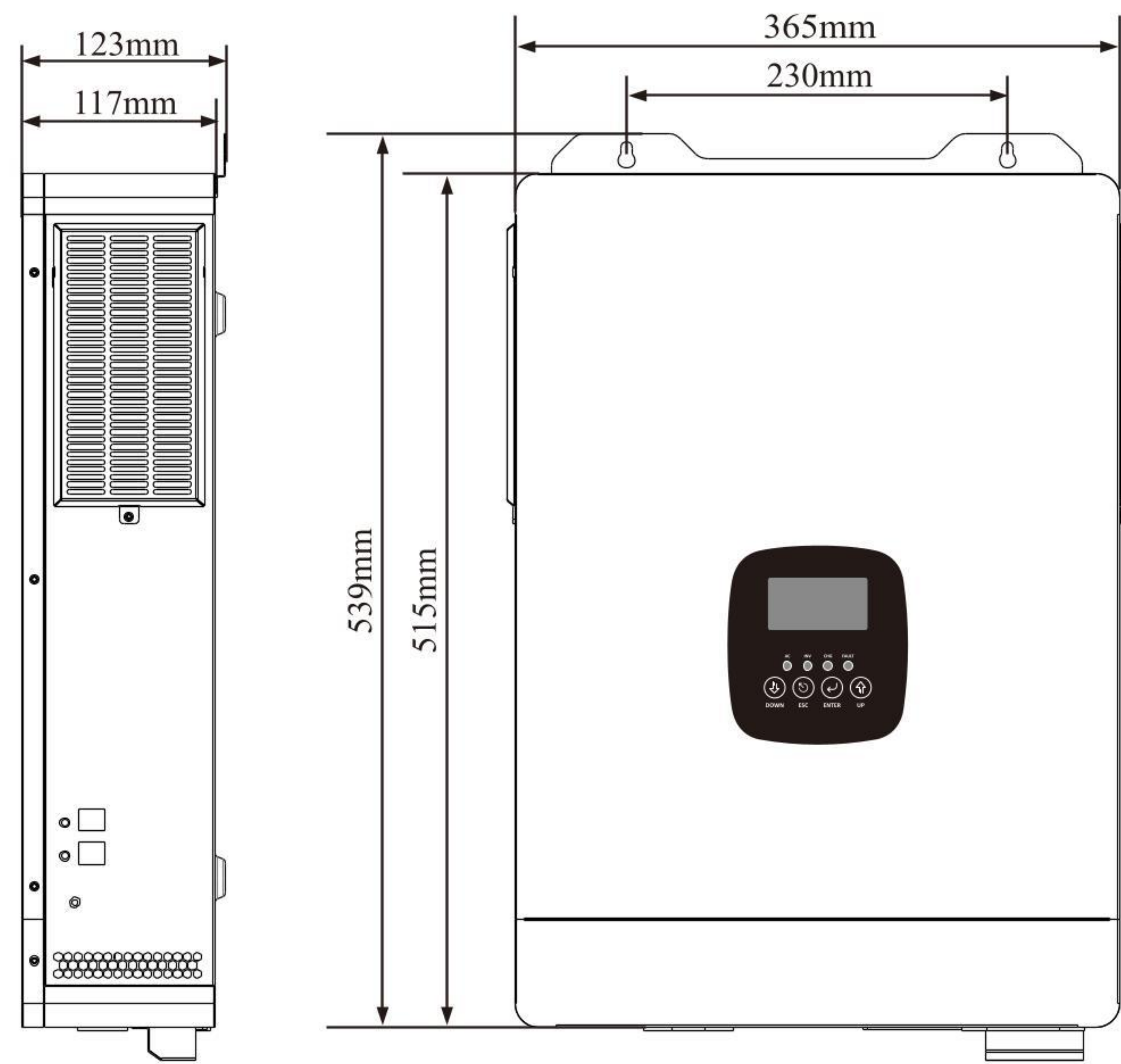

f. 12.3KW

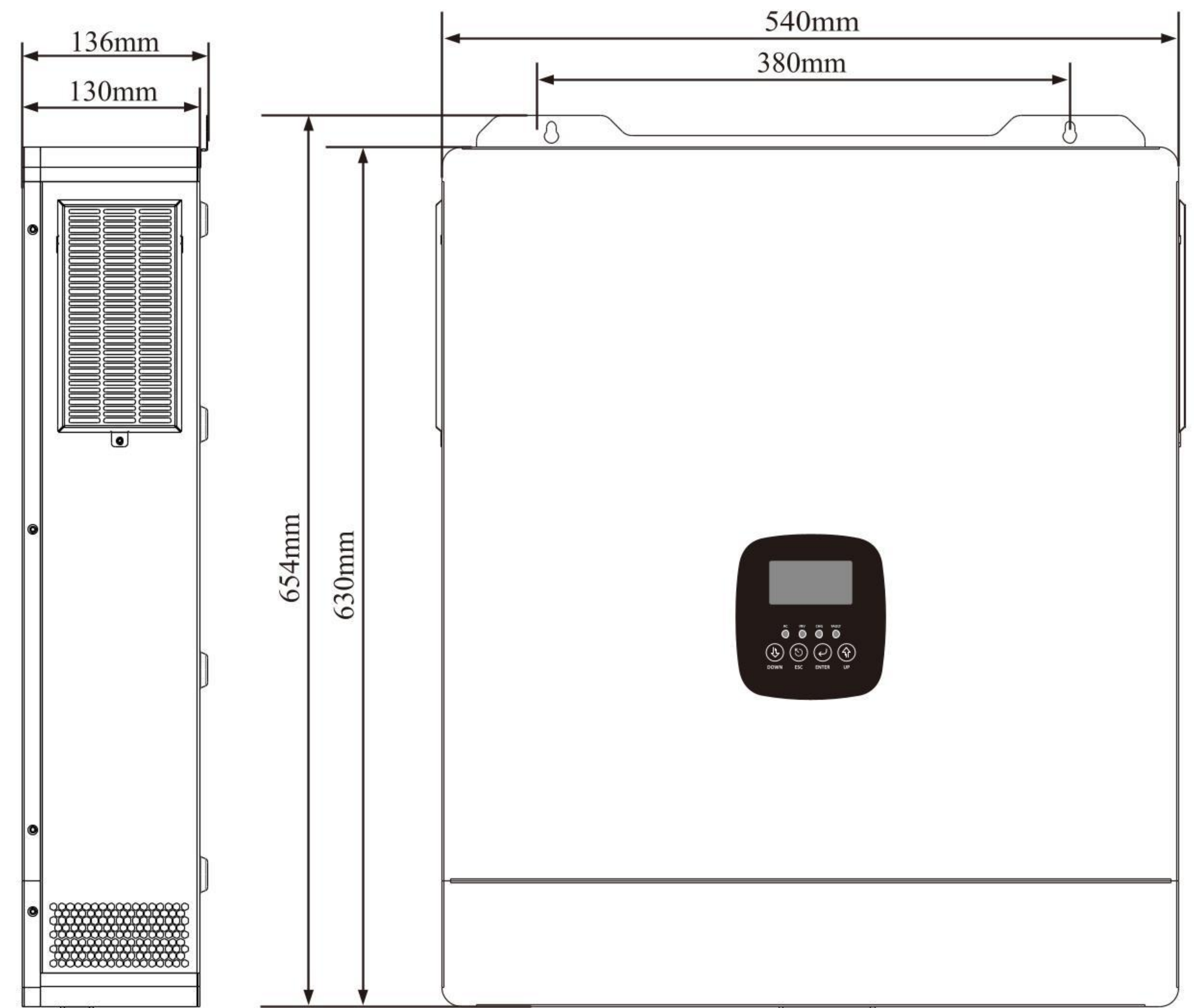

e. 10.3KW

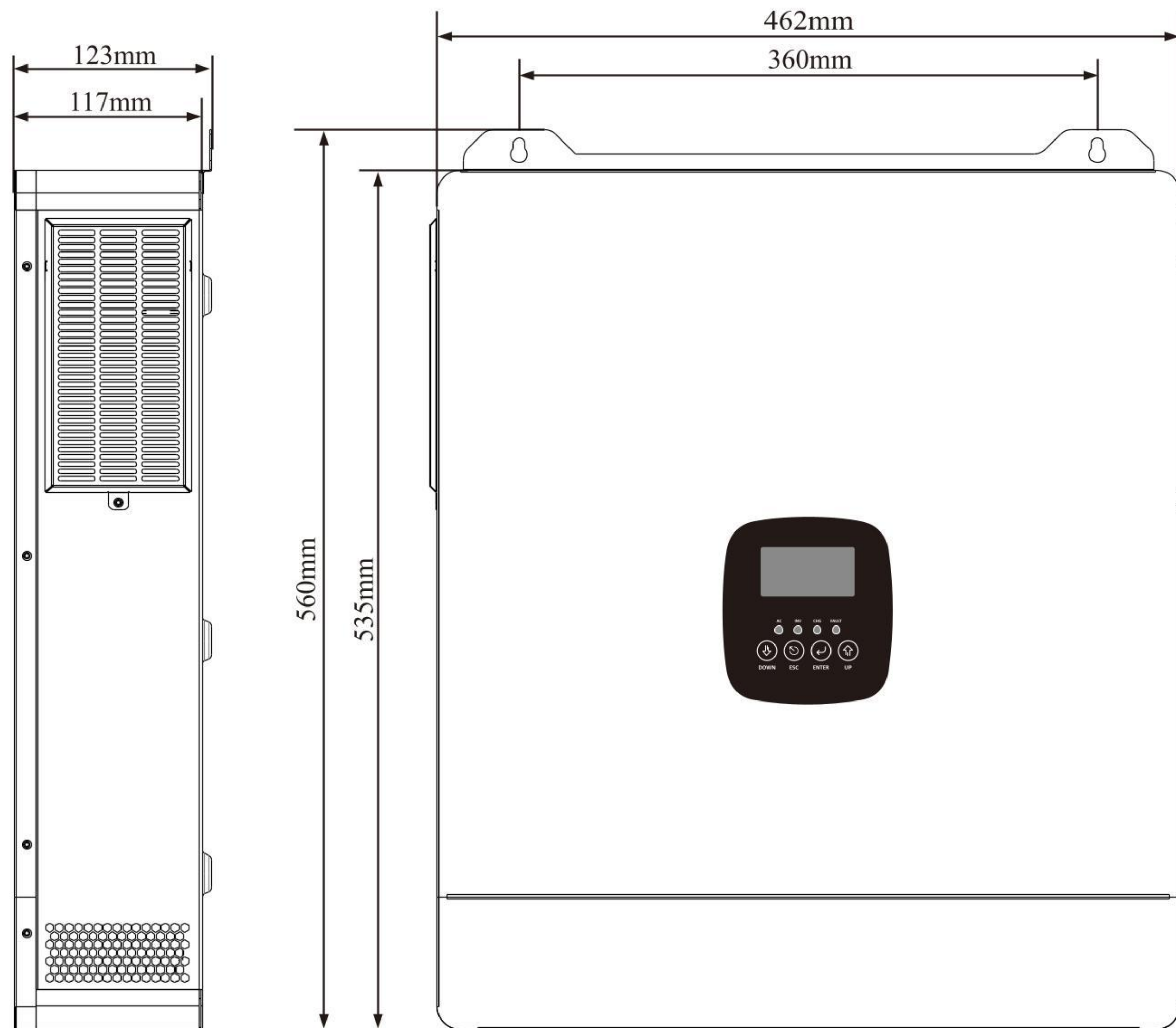

2) Wall mounting

a. Fix the wall mount on the machine with M4x6 screws (the wall mount and screws are shipped randomly)

3.3KW/4.3KW

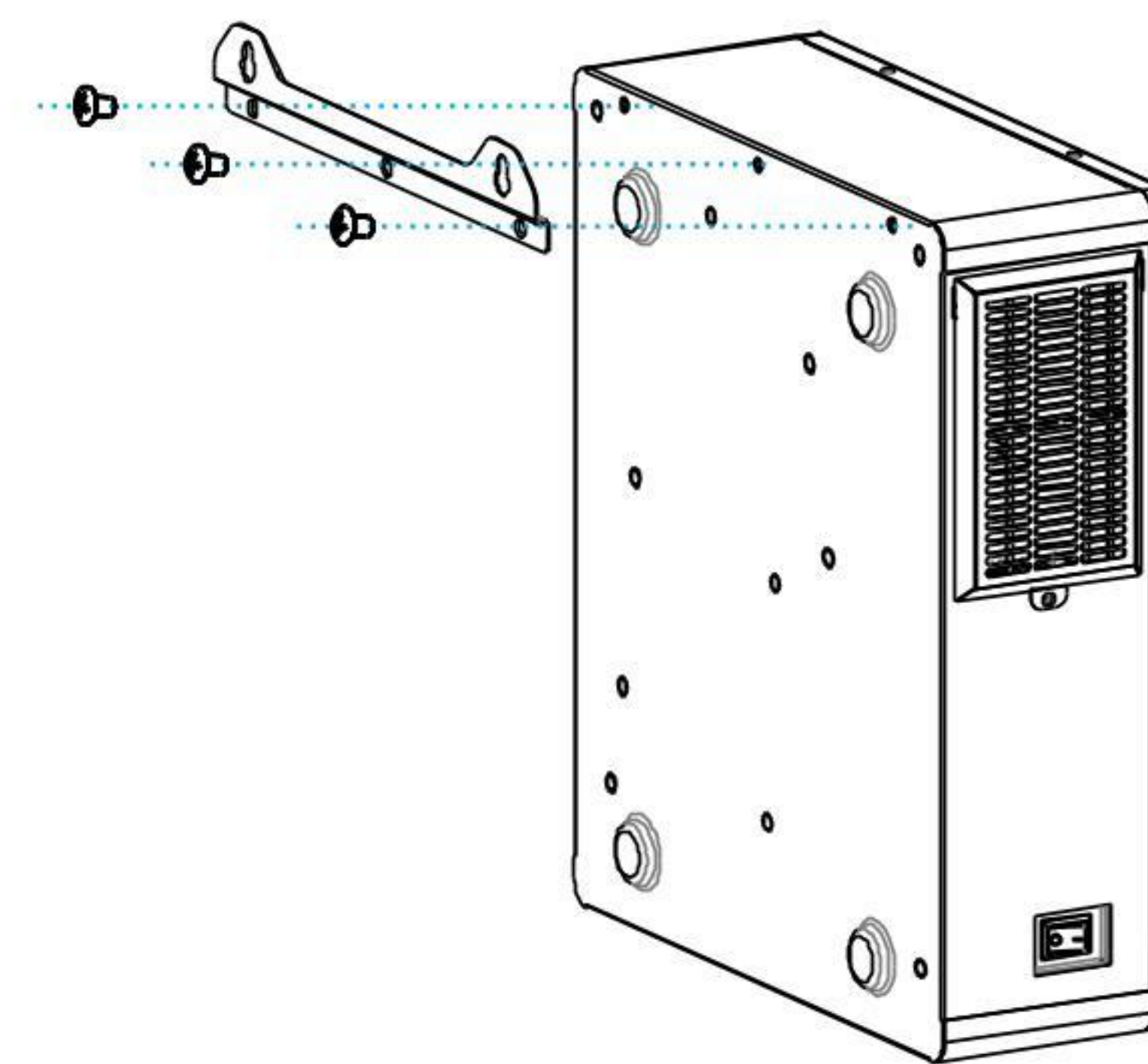

6.3KW

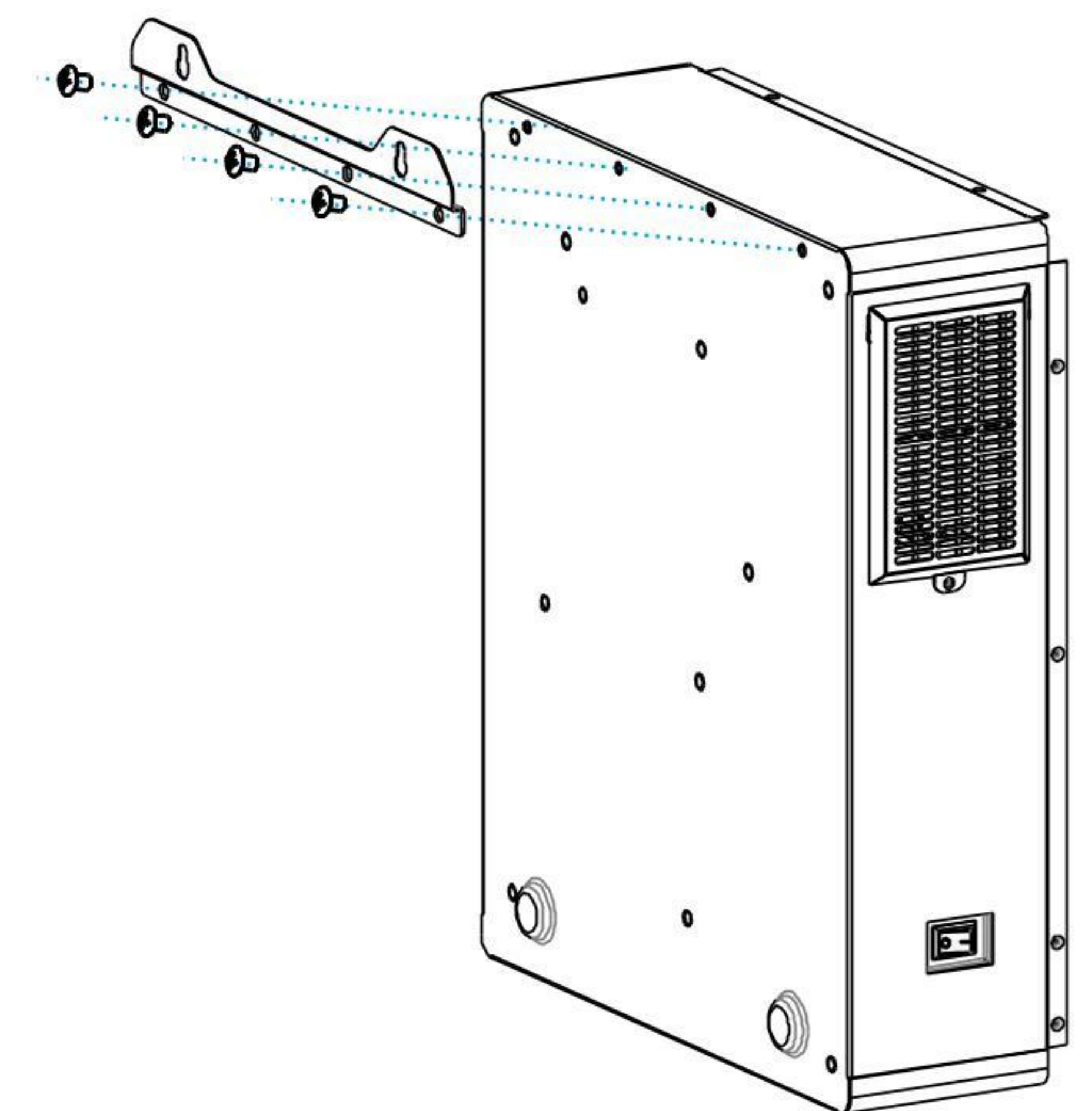

8.3KW/10.3KW/12.3KW

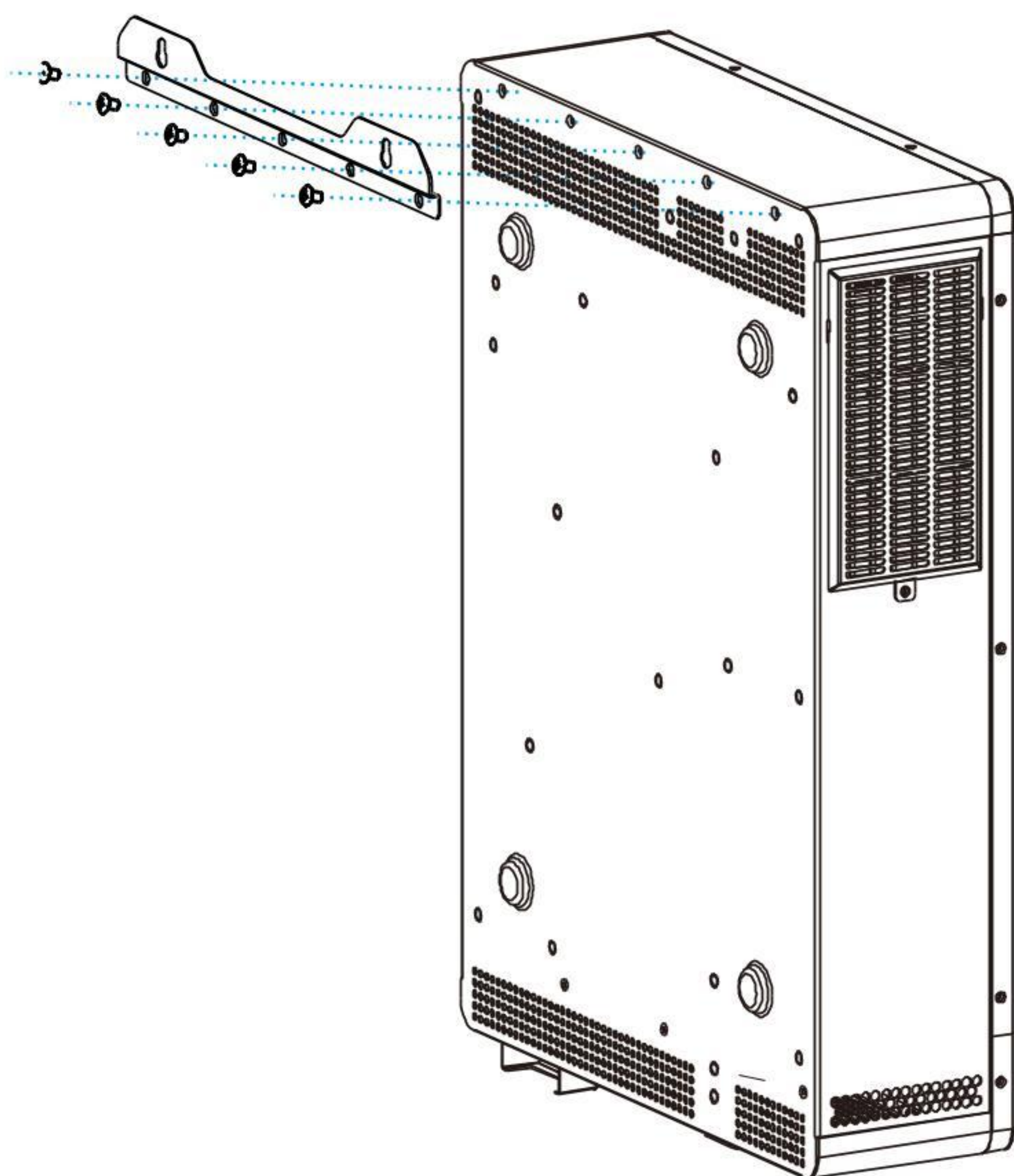

b. Tighten 2 screws to install the inverter. It is recommended to use M6 expansion screws (the screws need to be purchased by the user. For the specific installation hole distance, please check the markings on the machine size diagram)

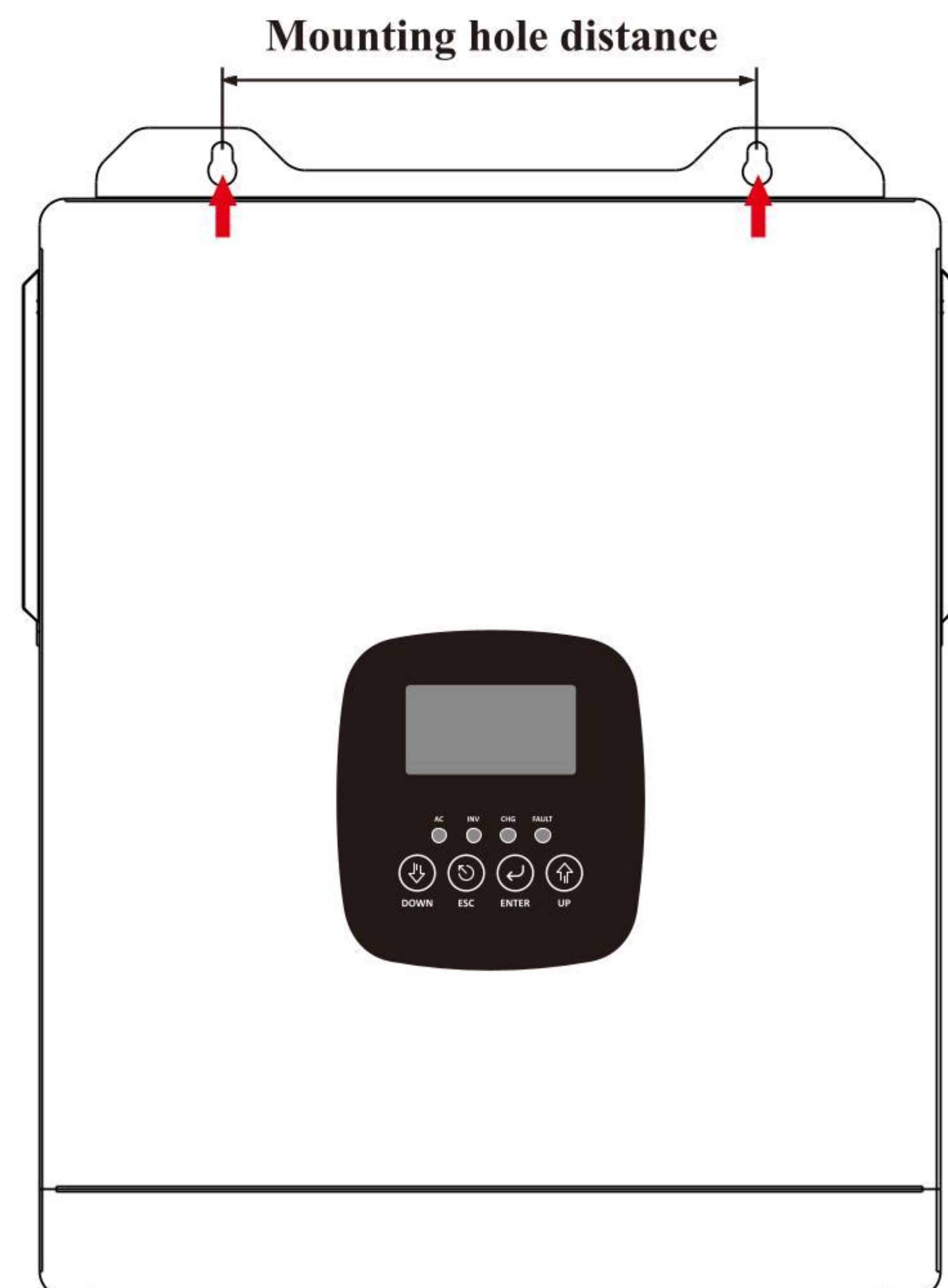

## 2. Outlook/Overview of Inverter

### 2.1 3.3KW/4.3KW/6.3KW

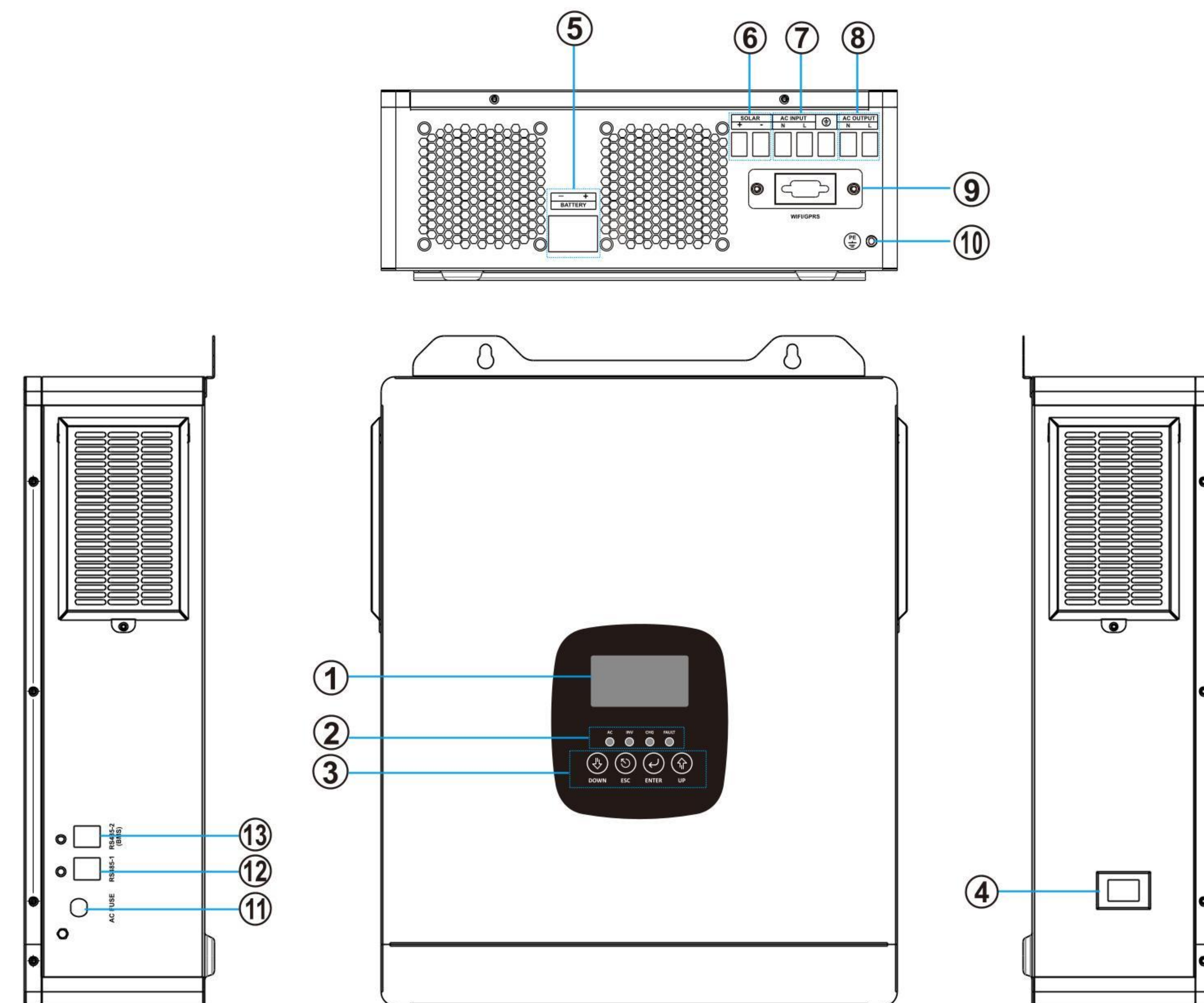

1. LCD display	2. LED indicator	3. Function button
4. Power on/off switch	5: Battery terminal port	6: PV input terminal port
7: AC input (on-grid) terminal		
8: AC output (backup output/uninterrupted output) wiring terminal port		
9: APP data collector module interface (WIFI/GPRS)		
10: Earth	11: AC Input fuse	
12: RS485-1 communication interface	13: RS485-2 communication interface (BMS communication)	

#### Notice:

\* Please see the appendix below for the interface definition.

\* The pictures may be different from the real products, please refer to the real product!

2.2 8.3KW

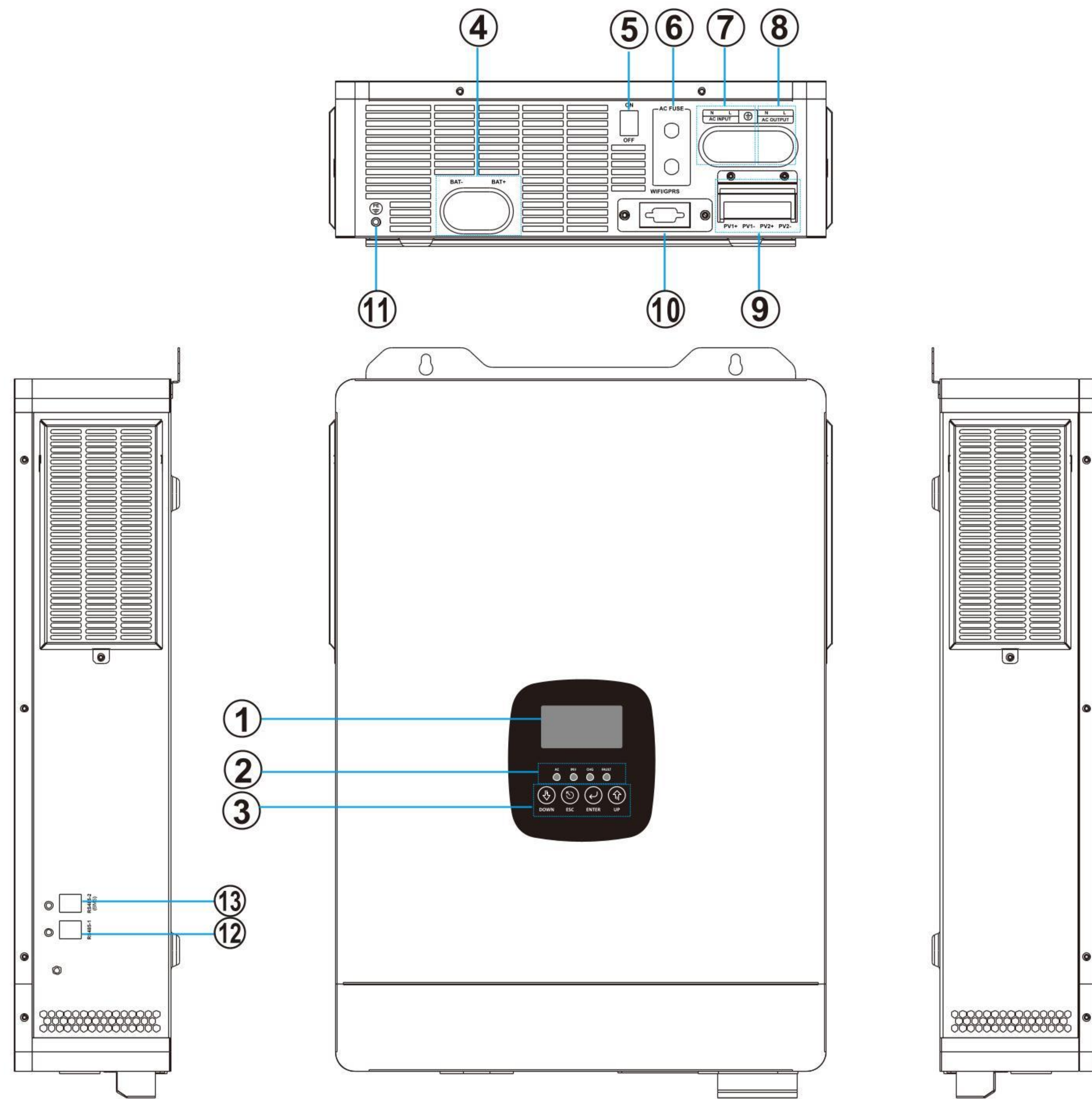

1. LCD display	2. LED indicator	3. Function button
4: Battery terminal port	5. Power on/off switch	6: AC Input fuse
7: AC input (on-grid) terminal		
8: AC output (backup output/uninterrupted output) wiring terminal port		
9: PV input terminal port	10: APP data collector module interface (WIFI/GPRS)	
11: Earth	12: RS485-1 communication interface	
13: RS485-2 communication interface (BMS communication)		

**Notice:**

- \* Please see the appendix below for the interface definition.
- \* The pictures may be different from the real products, please refer to the real product!

2.4 10.3KW

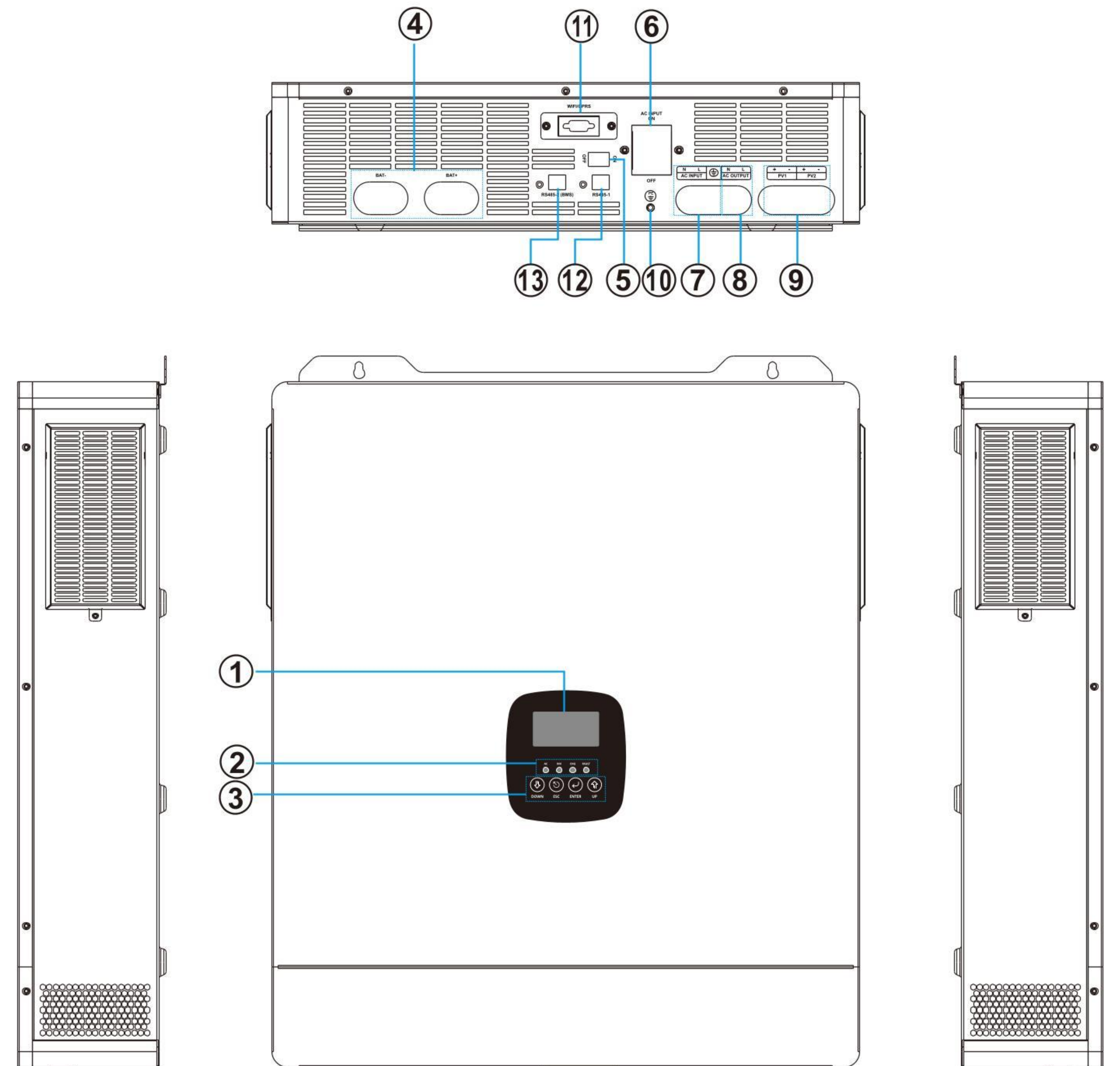

1. LCD display	2. LED indicator	3. Function button
4: Battery terminal port	5. Power on/off switch	6: Input circuit breaker
7: AC input (on-grid) terminal		
8: AC output (backup output/uninterrupted output) wiring terminal port		
9: PV input terminal port	10: Earth	
11: APP data collector module interface (WIFI/GPRS)	12: RS485-1 communication interface	
13: RS485-2 communication interface (BMS communication)		

**Notice:**

- \* Please see the appendix below for the interface definition.
- \* The pictures may be different from the real products, please refer to the real product!

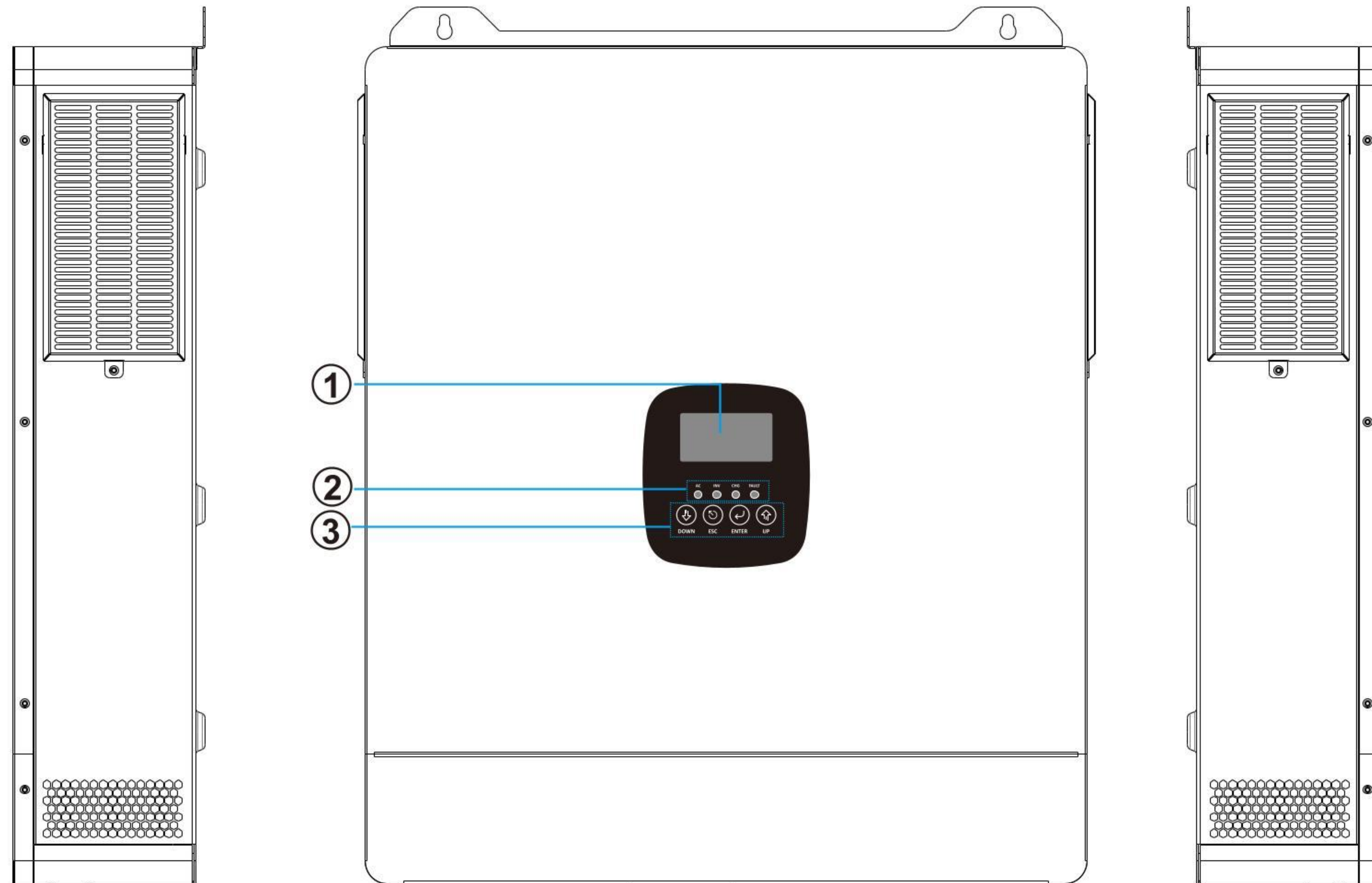
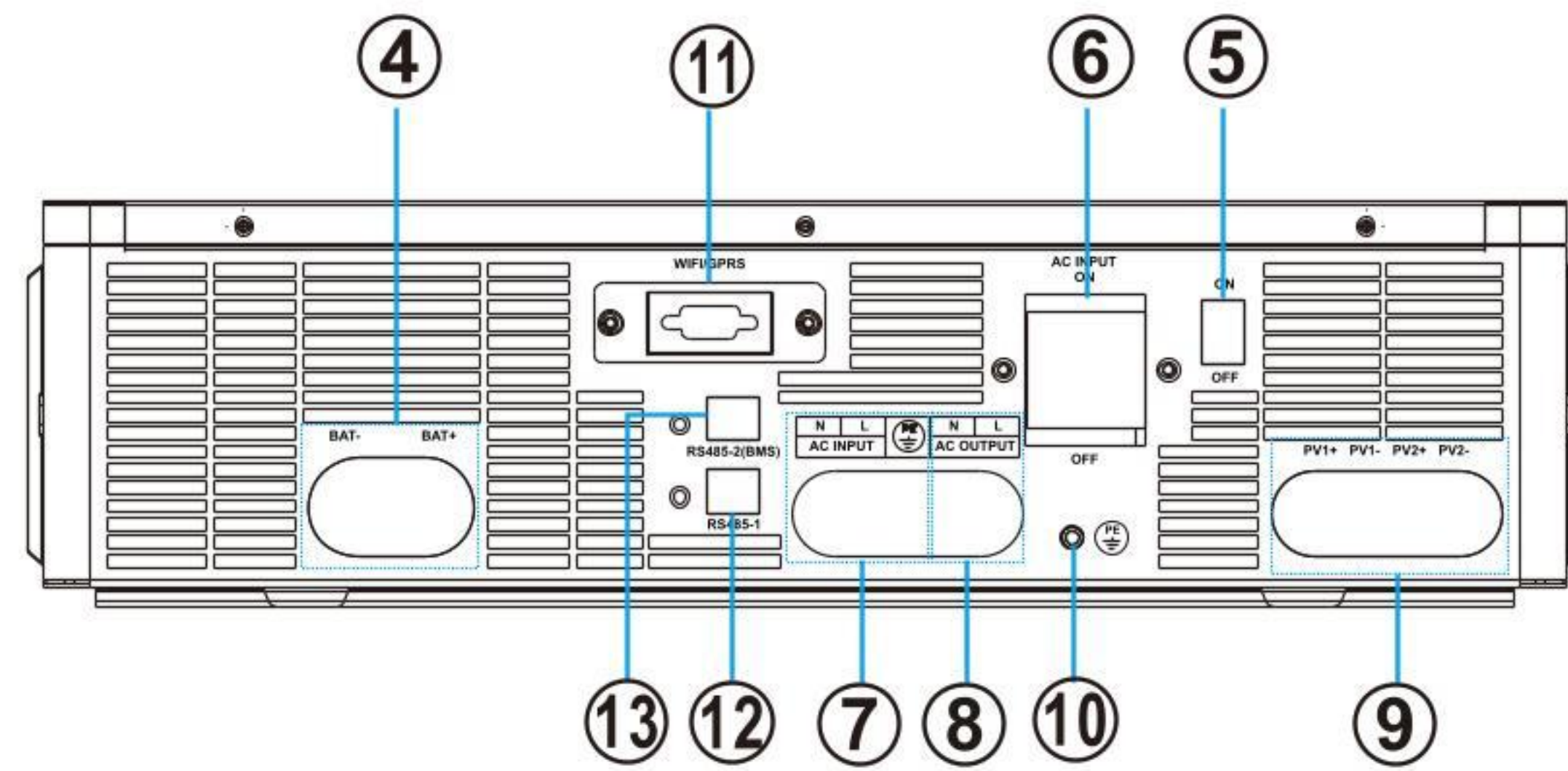

1. LCD display	2. LED indicator	3. Function button
4: Battery terminal port	5. Power on/off switch	6: Input circuit breaker
7: AC input (on-grid) terminal		
8: AC output (backup output/uninterrupted output) wiring terminal port		
9: PV input terminal port	10: Earth	
11: APP data collector module interface (WIFI/GPRS)	12: RS485-1 communication interface	
13: RS485-2 communication interface (BMS communication)		

**Notice:**

- \* Please see the appendix below for the interface definition.
- \* The pictures may be different from the real products, please refer to the real product!

### 3. Wiring instructions

#### Electrical connection precautions

When inverter connect with electrical, observe all current national regulations regarding the prevention of electrical accidents.ard that, if not be avoided, will result in personal injury or death.

	<ul style="list-style-type: none"> <li>• Always cover the PV panels with light-tight material or disconnect the DC side circuit breaker before making electrical connections.</li> <li>• When exposed to sunlight, photovoltaic arrays will generate dangerous voltages.</li> <li>• When install the battery, please confirm the positive and negative poles of the battery are connected in right way and break the battery connection.</li> </ul>
<b>DANGER</b>	
	<ul style="list-style-type: none"> <li>• All installation operations must be performed only by professional electrical engineers.</li> <li>• Must undergo training.</li> <li>• Read this manual completely and understand the relevant safety matters.</li> </ul>
<b>WARNING</b>	

#### Operation precautions

	<ul style="list-style-type: none"> <li>• Touching the terminals of the mains or equipment may result in death by electric shock or a fire!</li> <li>• Do not touch terminals or conductors connected to the mains circuit.</li> <li>• Pay attention to any instructions or safety documentation regarding grid connection.</li> </ul>
<b>DANGER</b>	
	Some internal components will become hot during operation, please wear protective gloves.
<b>NOTE</b>	

#### Maintenance and repair precautions

	<ul style="list-style-type: none"> <li>• Before carrying out any maintenance work, first disconnect the inverter from the electrical grid and then disconnect the DC side electrical connection.</li> <li>• Wait at least 5 minutes until the internal components are discharged before proceeding with maintenance work.</li> </ul>
<b>DANGER</b>	
	<ul style="list-style-type: none"> <li>• Any fault that affects the safety performance of the inverter must be eliminated before the inverter can be turned on again. If any maintenance work is required, please contact our maintenance center.</li> <li>• Do not disassemble or assemble the internal components of the inverter without authorization. Our company will not be responsible for the warranty and joint liability for the resulting losses.</li> </ul>
<b>NOTE</b>	



### 3. Wiring instructions

(Note: Please see the technical parameter table for specific battery voltage, AC voltage and solar panel parameters. This picture is only a wiring diagram.)

#### 3.1 3.3KW/4.3KW/6.3KW

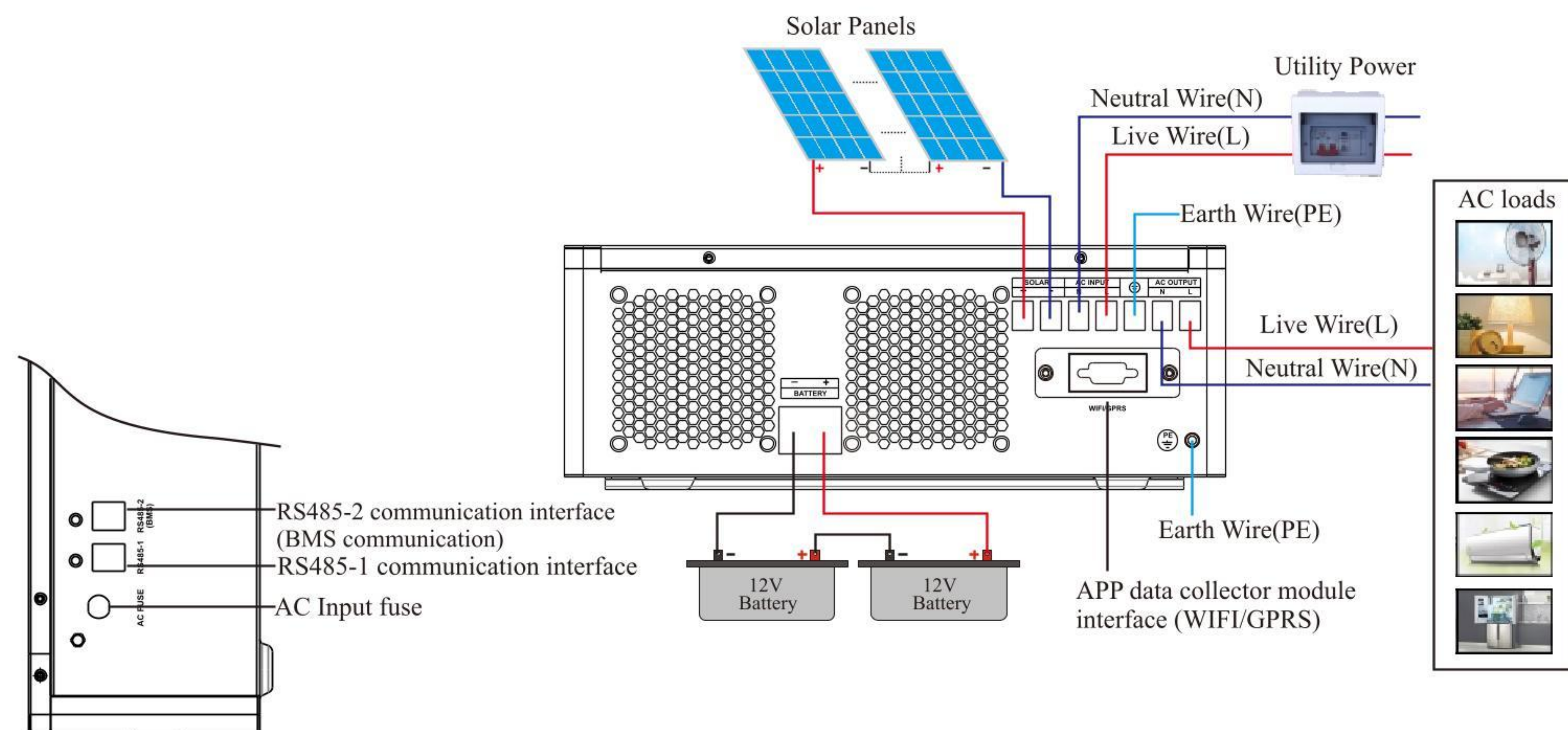

#### 3.2 8.3KW

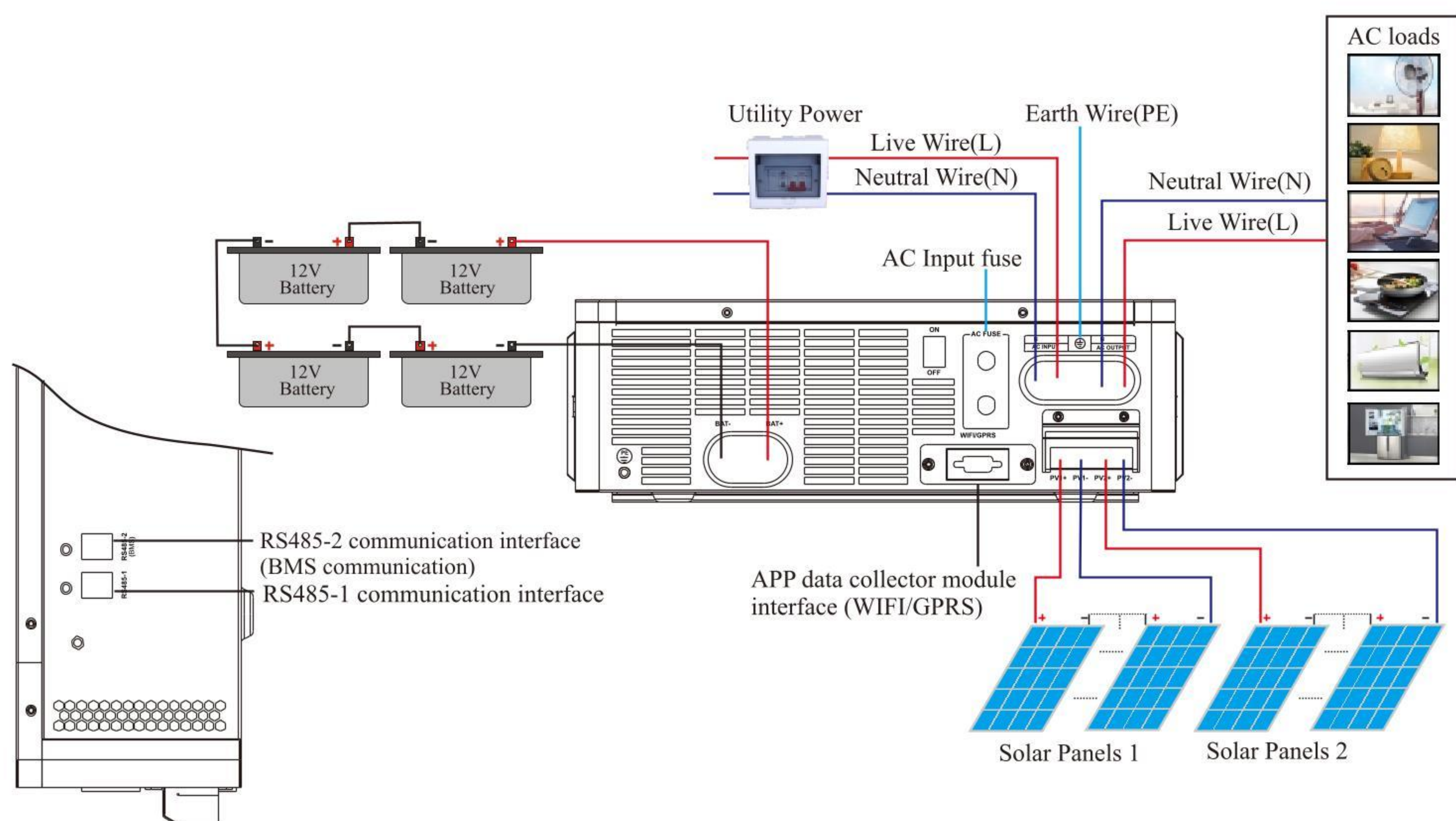

#### 3.3 10.3KW

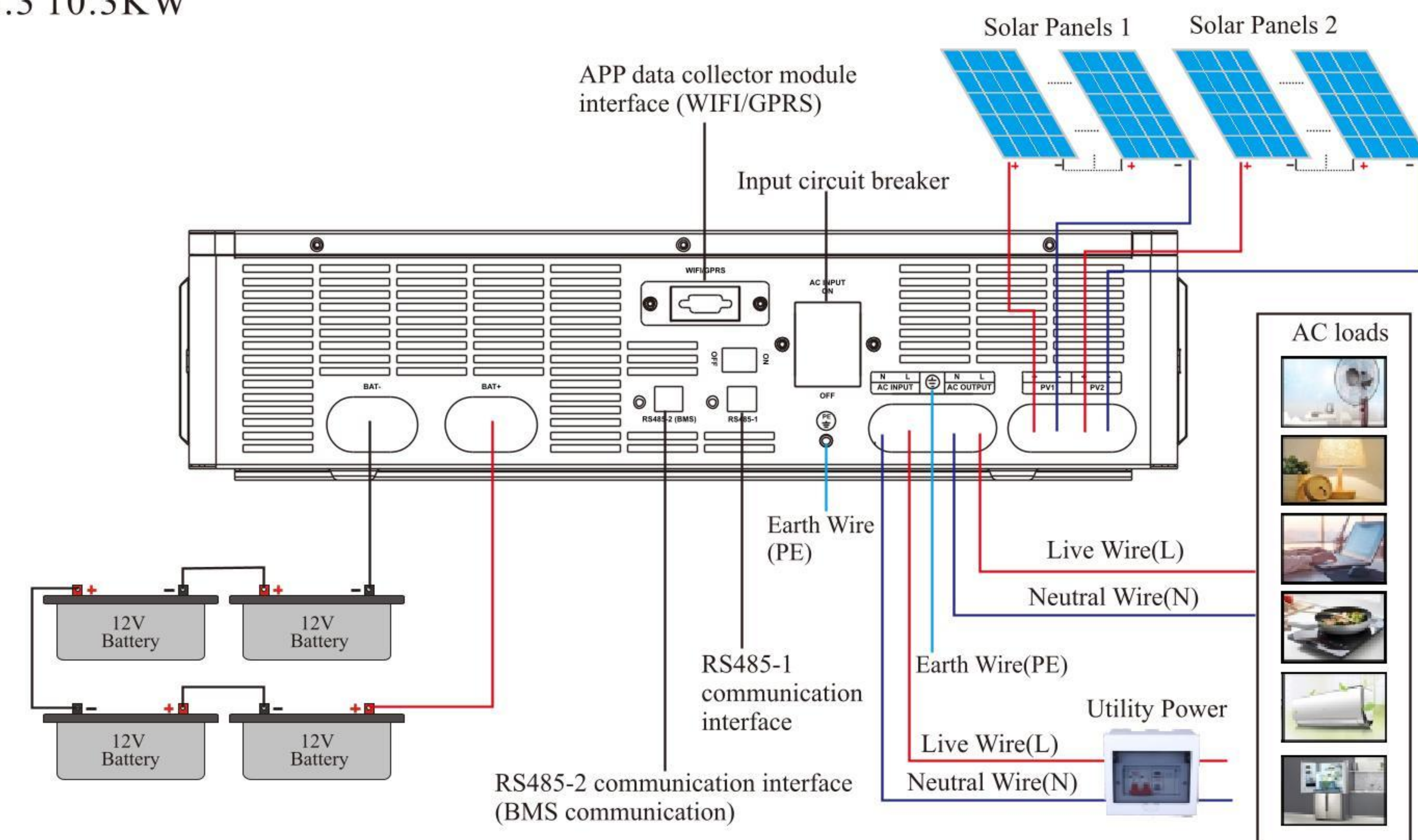

#### 3.4 12.3KW

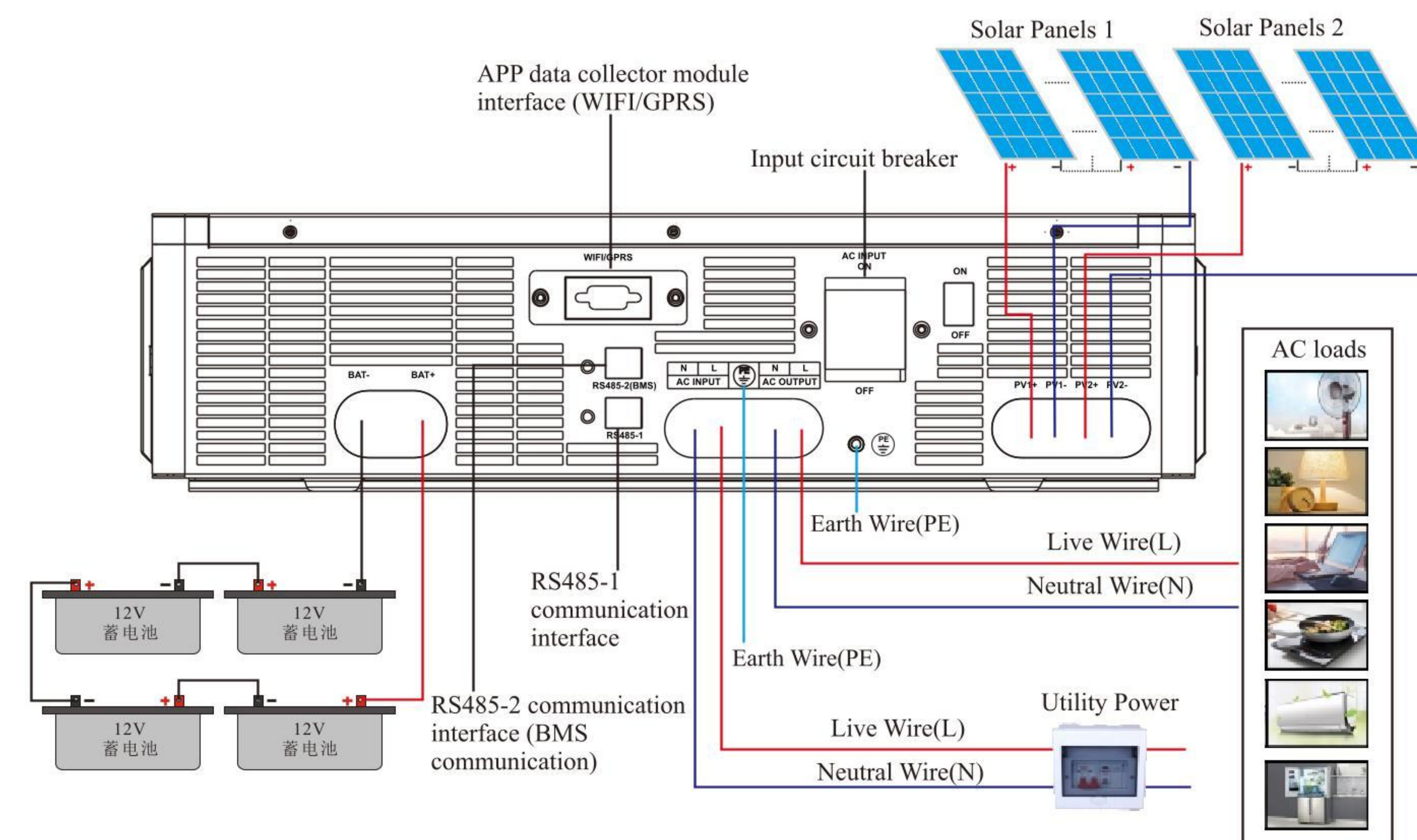

#### Note:

- When connecting the battery and photovoltaic, pay attention to the positive and negative poles of the cable, and do not connect them reversely;
- If connecting a generator, please start the generator first, and then connect to the inverter mains input after it runs stably. If to the output end of the generator, then start the inverter, and finally connect to the user equipment after the inverter becomes normal;
- It is recommended that the generator capacity is  $\geq$  three times the inverter rated capacity.

### 3.3KW/4.3KW/6.3KW

#### Preparation

Before connecting all wirings, please take off bottom cover by removing screws as shown below.

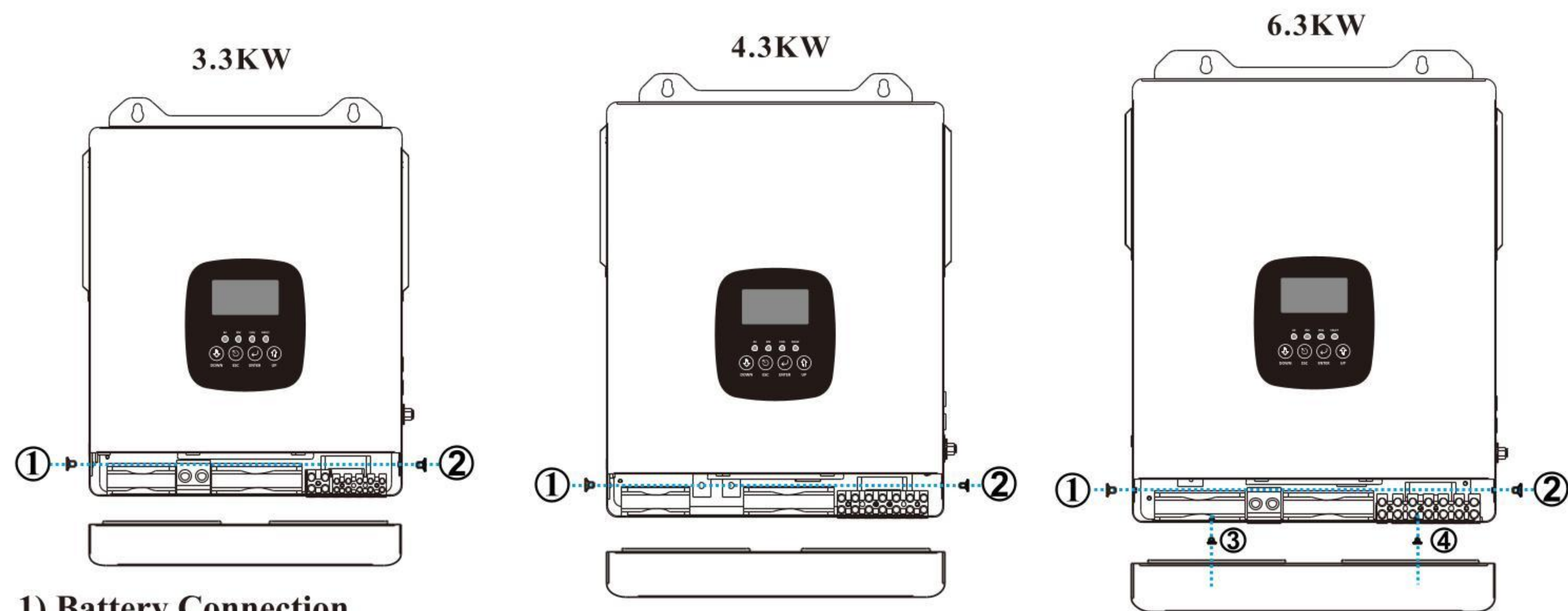

#### 1) Battery Connection

Please follow below steps to implement battery connection:

- Remove insulation sleeve 6 mm for positive and negative conductors.(4.3KW model, positive and negative wires need to assemble ring terminals)
- Check correct polarity of connection cable from battery modules and battery input connectors. Then, connect positive pole (+) of connection cable to positive pole (+) of BATTERY input connector. Connect negative pole (-) of connection cable to negative pole (-) of BATTERY input connector.
- Make sure the polarity of the wiring is correct and the connection is firm. Make sure there is no short circuit between the positive and negative electrodes.

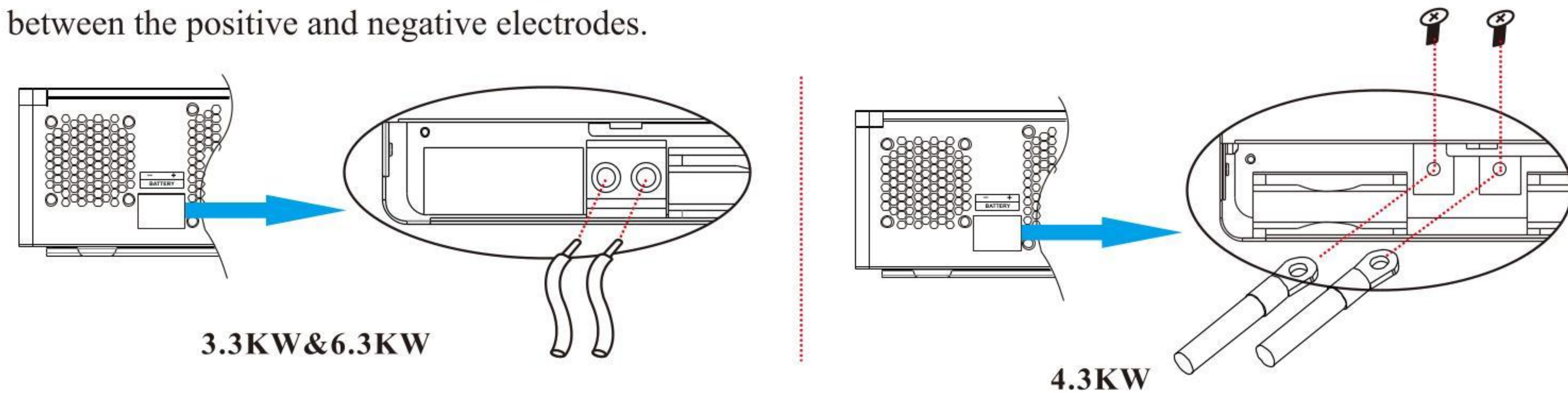

#### 2)AC input (grid tie terminal/connected to mains power), AC output (uninterrupted output/connected to AC load) connection

**CAUTION!! There are two terminal blocks with “INPUT” and “OUTPUT” markings. Please do NOT mis-connect input and output connectors.**

Please follow the following steps to connect the AC input / AC output cable:

- Before connecting to AC input power source, please install a separate AC breaker between inverter and AC input power source. This will ensure the inverter can be securely disconnected .
- Remove insulation sleeve 10mm for five conductors.
- Insert AC Input wires according to polarities indicated on terminal block and tighten the terminal screws. Be sure to connect PE protective conductor first.

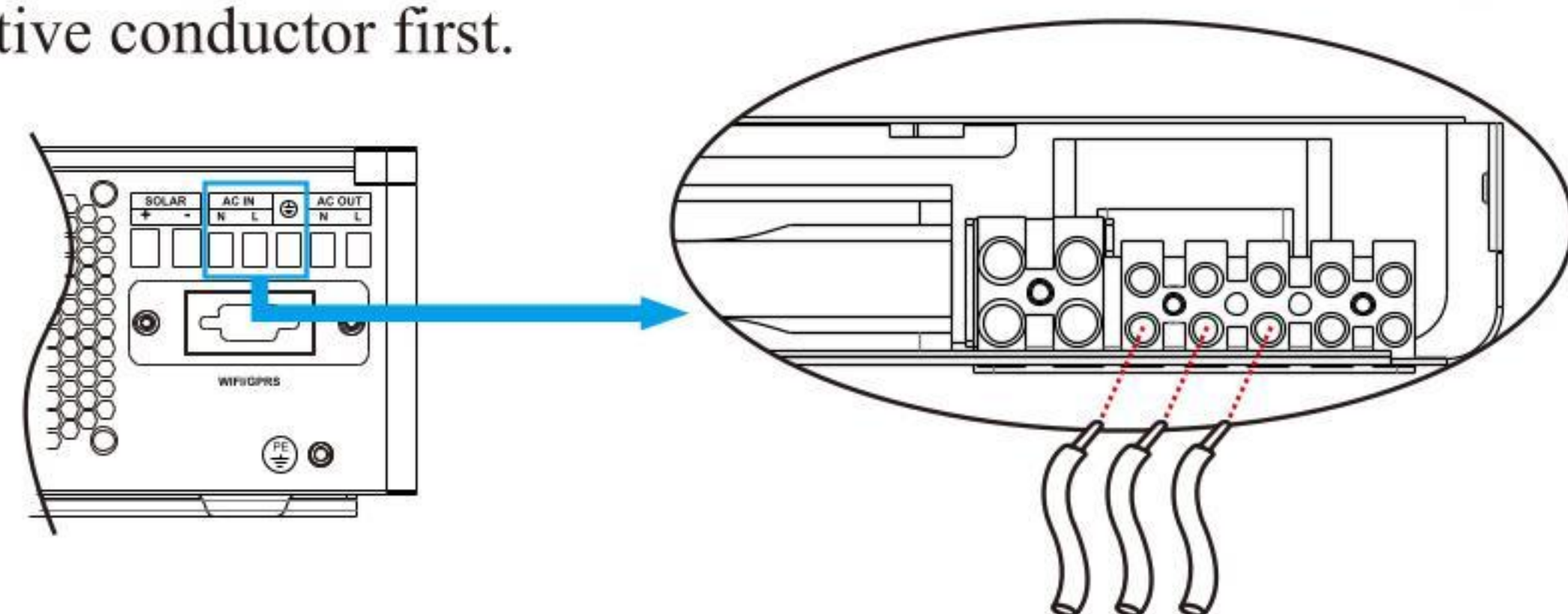

- Then, insert AC output wires according to polarities indicated on terminal block and tighten terminal screws.

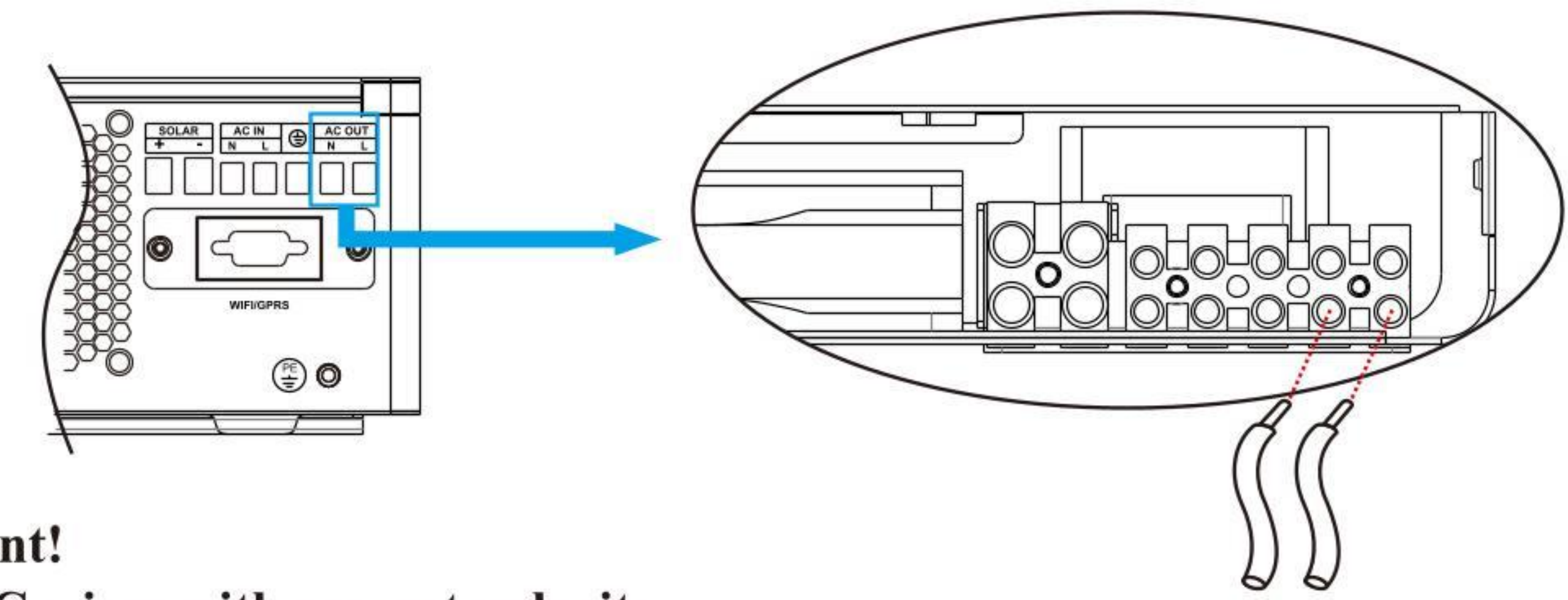

#### CAUTION: Important!

Be sure to connect AC wires with correct polarity.

#### 3) PV Connection

Please follow below steps to implement PV module connection:

- Remove insulation sleeve 10 mm for positive and negative conductors.
- Check correct polarity of connection cable from PV modules and PV input connectors. Then, connect positive pole (+) of connection cable to positive pole (+) of SOLAR input connector. Connect negative pole (-) of connection cable to negative pole (-) of SOLAR input connector.
- Make sure the polarity of the wiring is correct and the connection is firm.

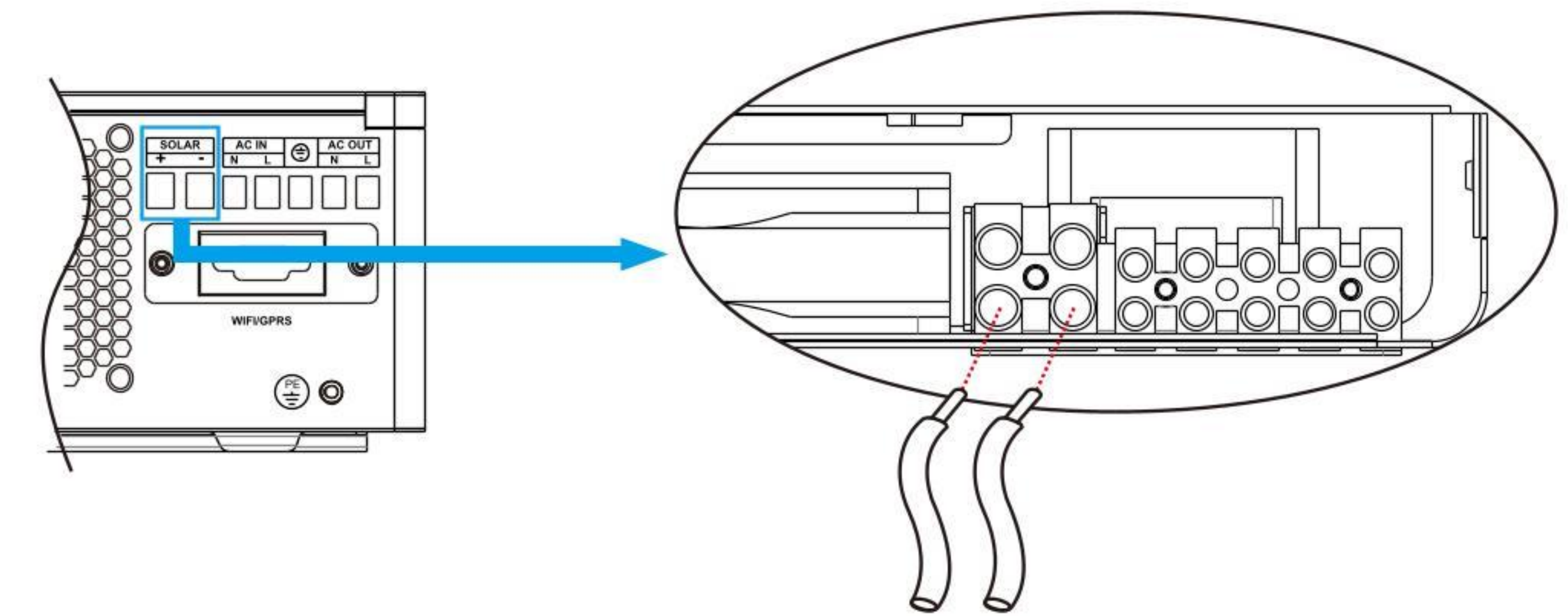

#### Final Assembly

After connecting all wirings, please put bottom cover back by screwing screws as shown below.

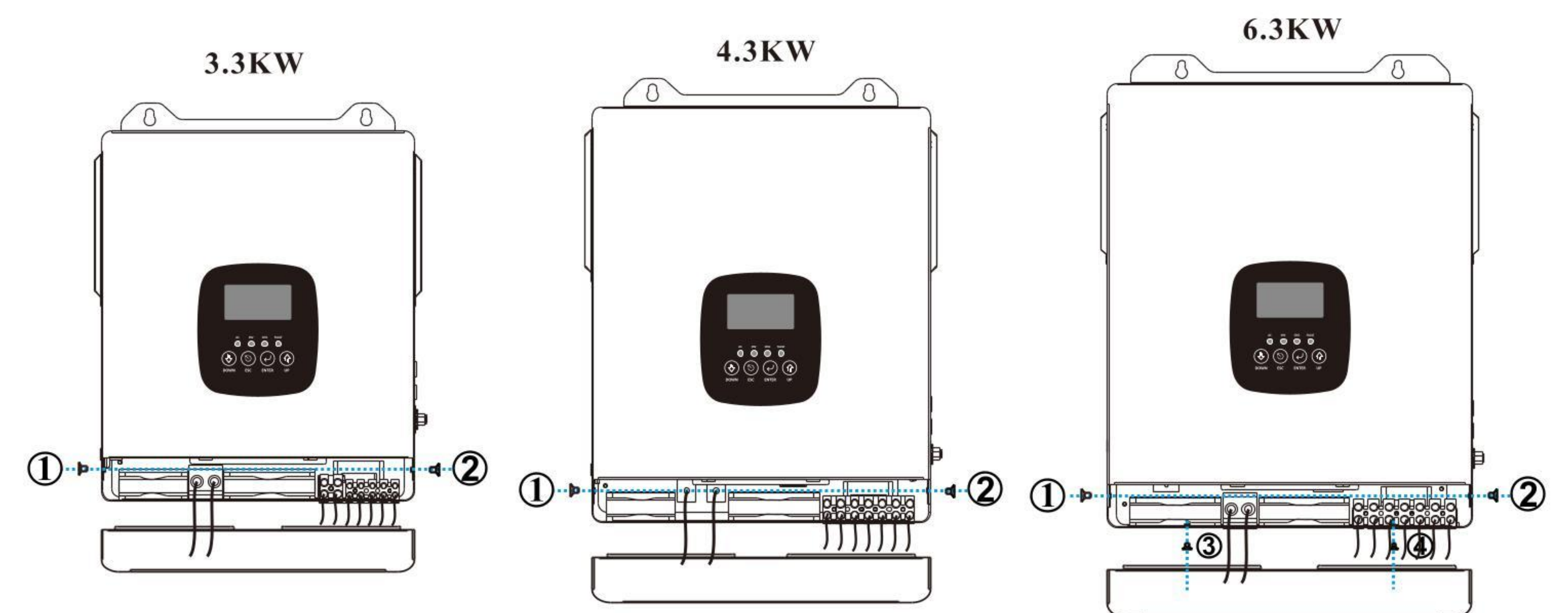

Note : The image shown here is indicative only. The actual product may differ.



#### WARNING:

Be sure that AC power source is disconnected before attempting to hardwire it to the unit.

## 8.3KW/10.3KW/12.3KW

### Prepare:

Before wiring, please remove the 4 screws on the bottom cover and move the cover away, as shown in the figure below

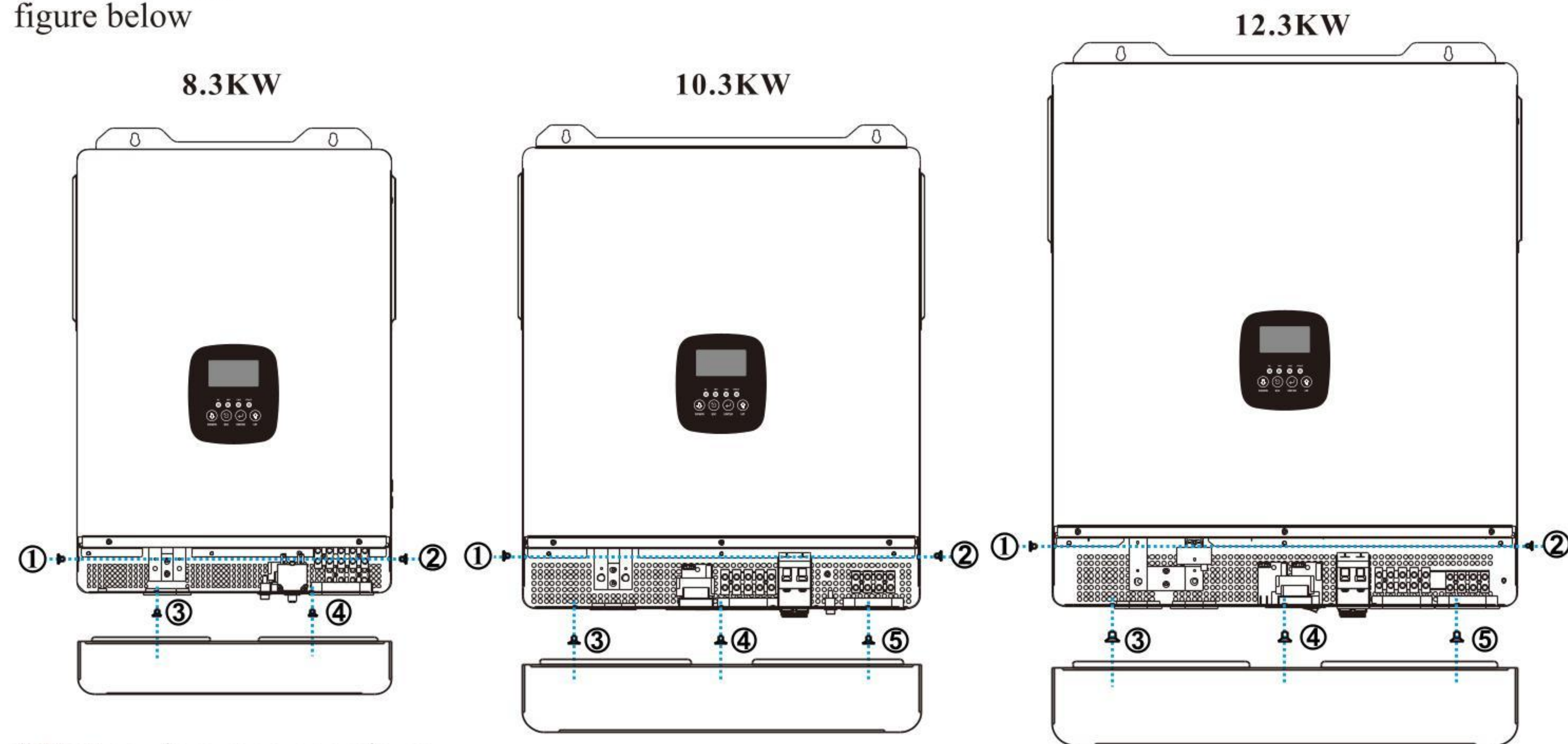

### 1) Battery input connections

Please follow the steps below to complete the battery connection

- Assemble the battery ring terminals and wiring according to the recommended battery wire diameter and terminal specifications.
- Whether the positive and negative poles of the connecting cable connecting the battery assembly and the battery input connector are correct. First unscrew the screws at the battery terminal port, insert the assembled battery wiring ring terminal flatly into the battery port of the inverter, and then tighten the screws.
- Confirm that the wiring polarity is correct and the ring terminal is locked with the battery terminal of the inverter. Make sure there is no short circuit between the positive and negative electrodes.

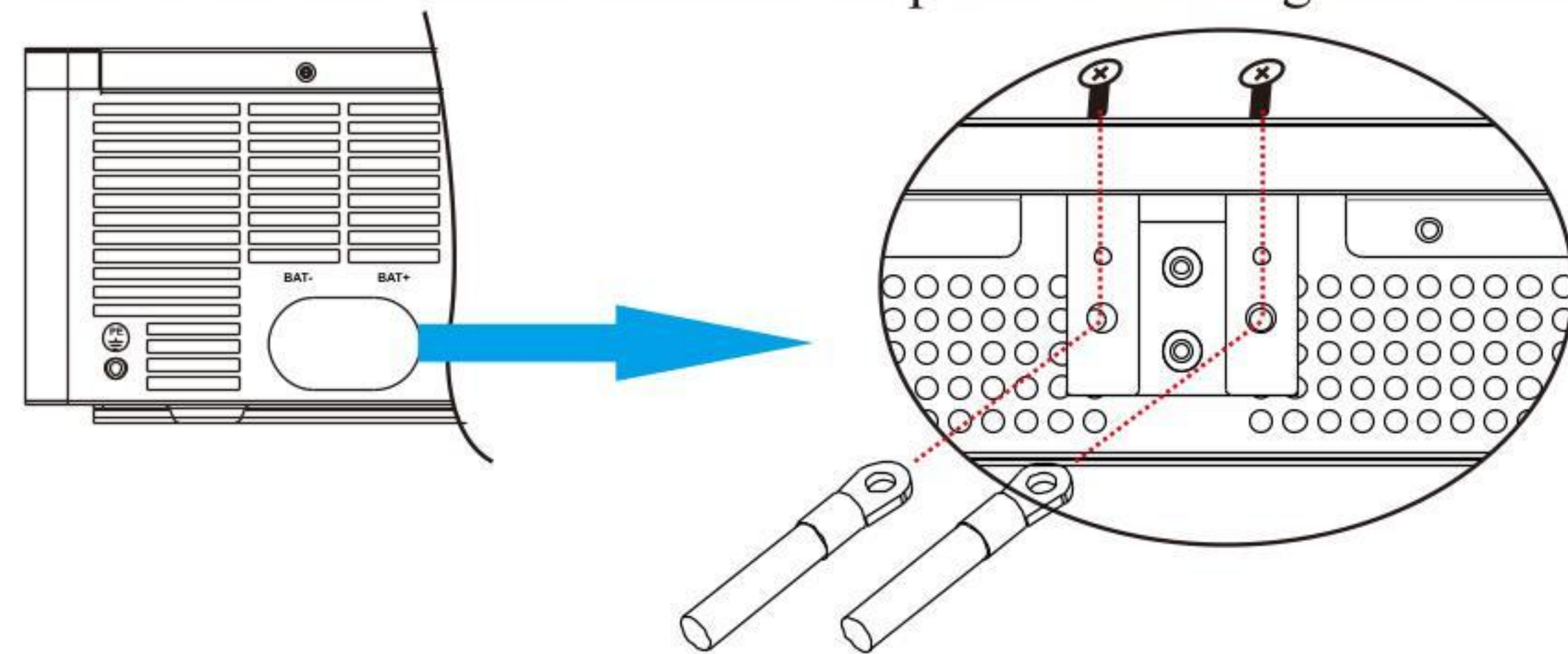

### 2) AC input (grid tie terminal/connected to mains power), AC output (uninterrupted output/connected to AC load) connection

**Attention! The terminal blocks are marked "INPUT" and "OUTPUT", please do not connect the input and output terminals incorrectly**

Please follow the steps below to connect the AC input/AC output cables:

- Before connecting the AC input and output, make sure the battery circuit breaker is disconnected.
- Peel off the insulation of the five wires by approximately 10mm.
- According to the polarity markings on the terminal block of the AC input end (INPUT), insert the AC cable into the terminal block and tighten the terminal block screws. Please connect the ground wire (PE) first

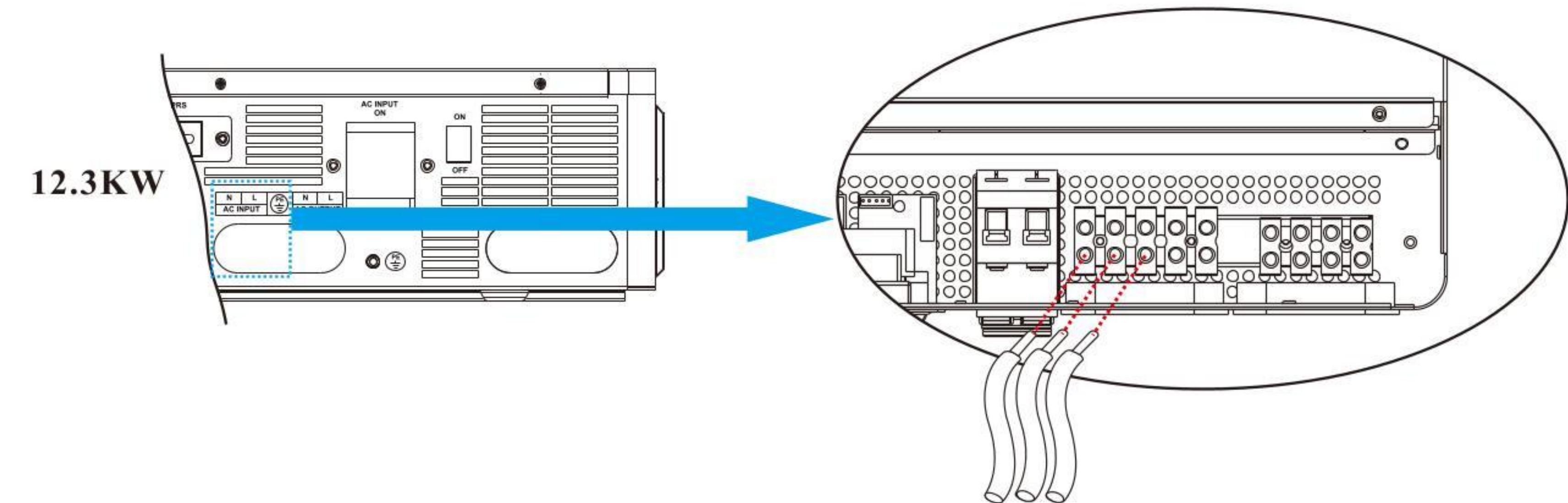
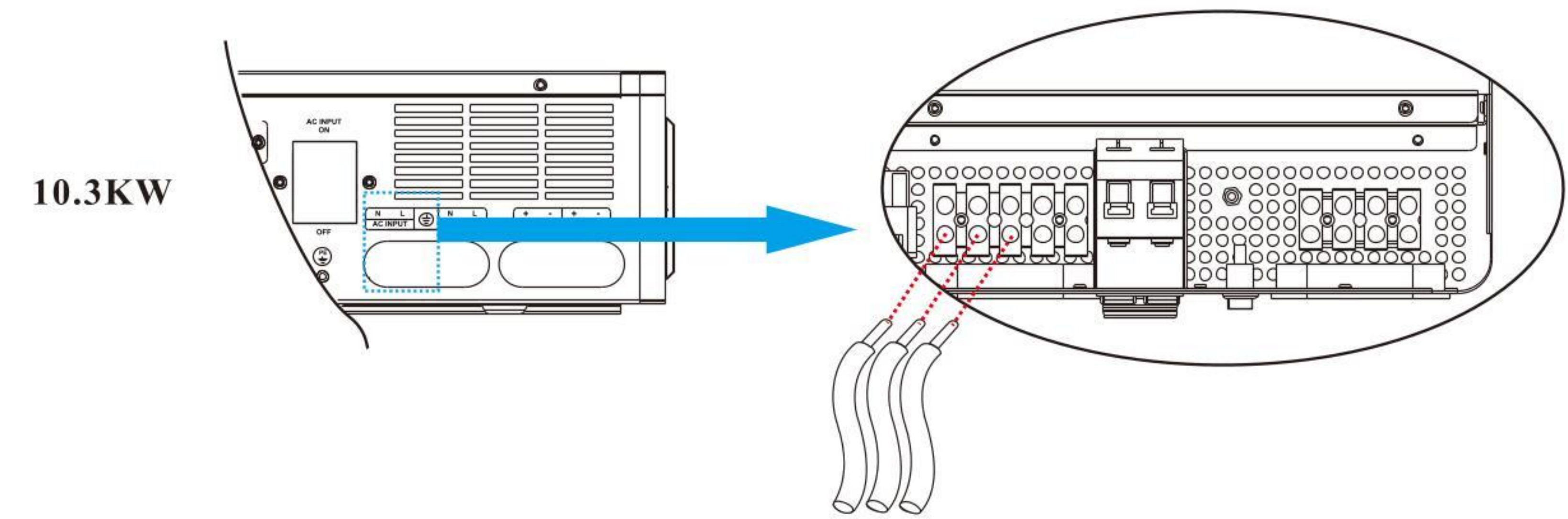
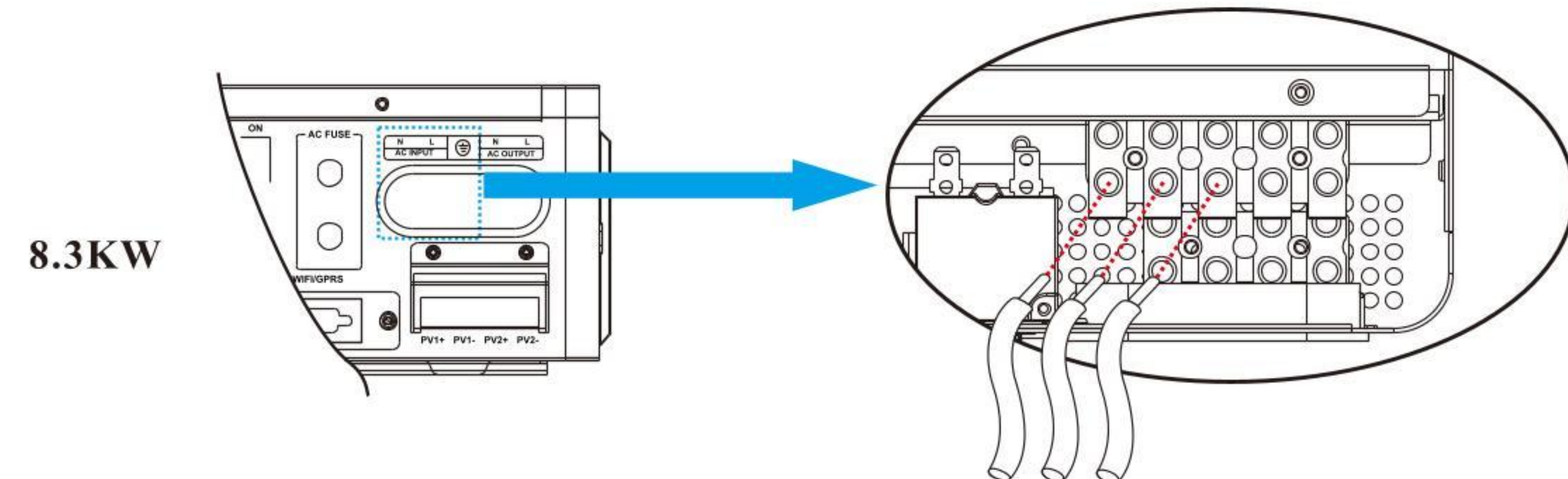

- According to the polarity markings on the AC output terminal (OUTPUT) terminal block, insert the AC cable into the terminal block and tighten the terminal block screws.

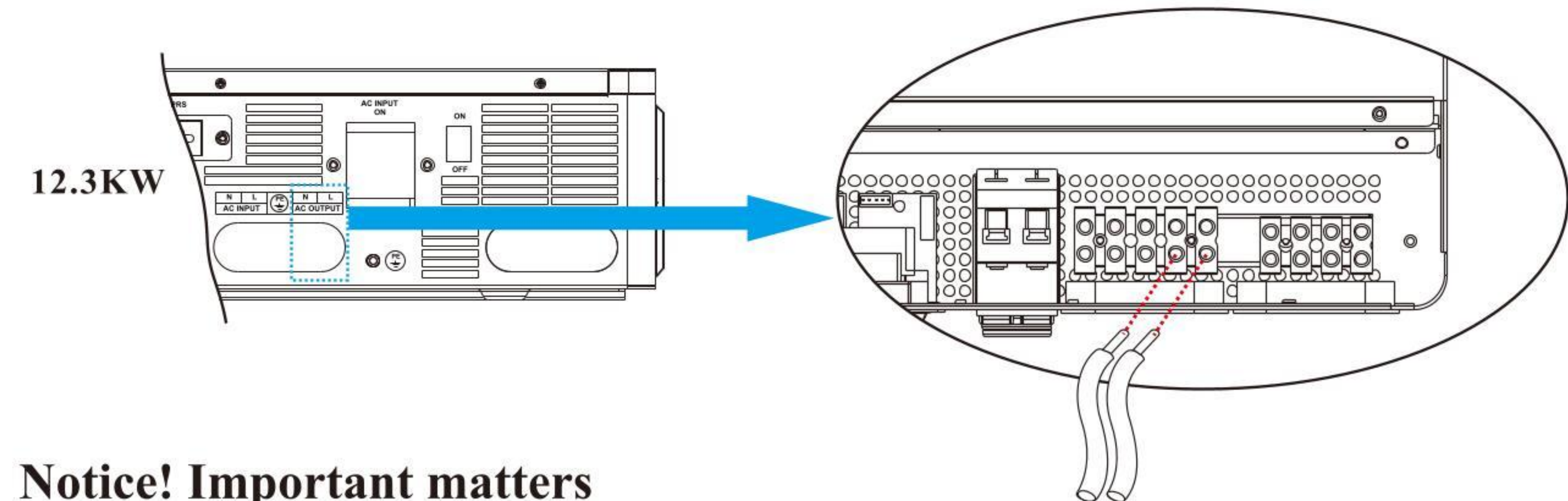
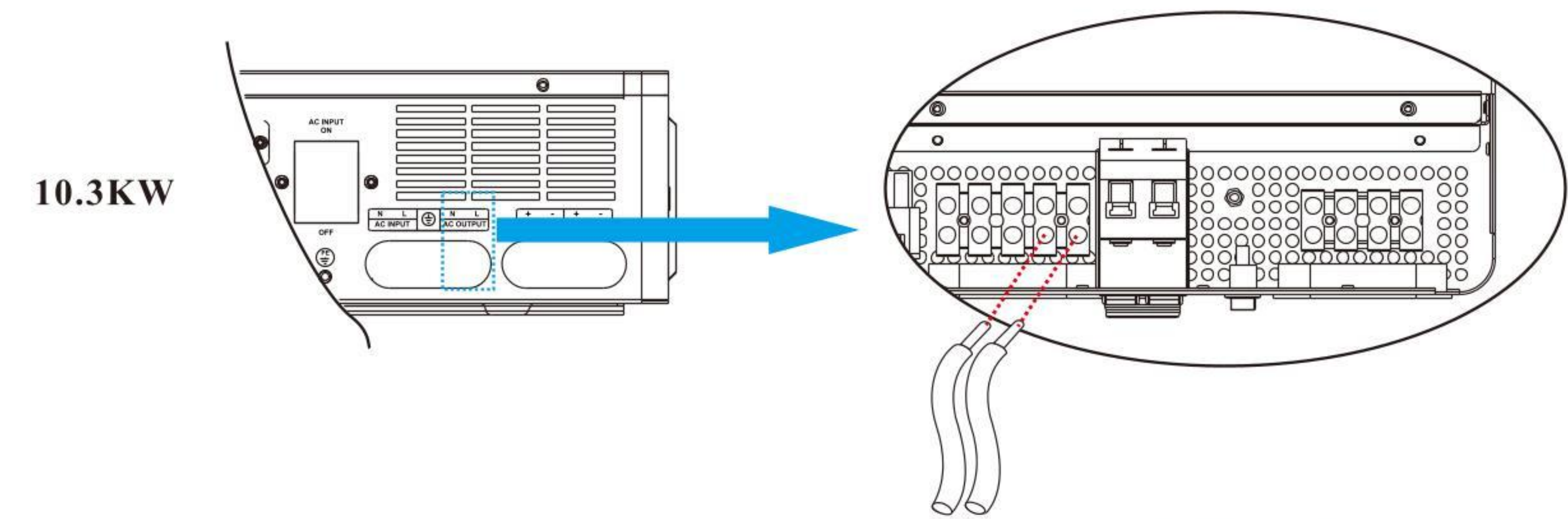
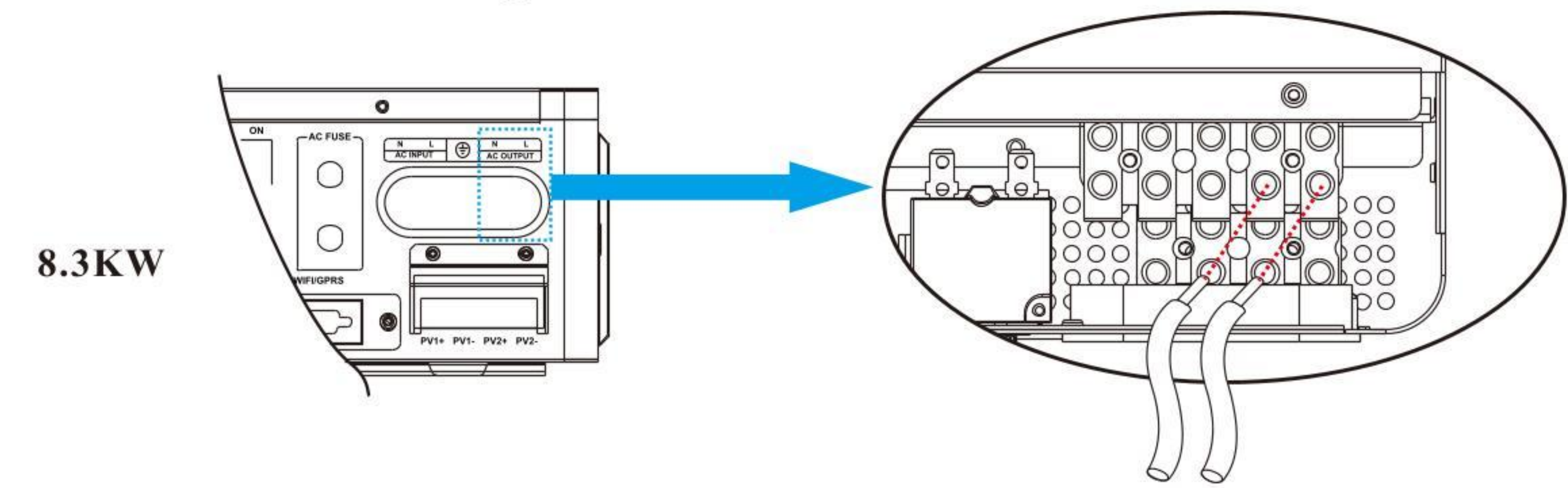

### Notice! Important matters

**Please ensure that the AC input and output cables are connected correctly in the neutral sequence**

**3)PV input connection (8.3KW/10.3KW/12.3KW models have 2 MPPT inputs, please ensure that the PV arrays connected to PV1/PV2 are 2 independent channels)**

Please follow the steps below to connect the solar module input:

- Peel off the insulation of the positive and negative wires by about 10mm.
- Check whether the positive and negative poles of the connecting cable connecting the solar module to the solar input connector are correct. After that, connect the positive pole (+) of the connecting cable to the (PV+ terminal block) on the inverter. Connect the negative pole (-) of the connecting cable to the (PV-terminal block) on the inverter
- Confirm that the wiring is firmly connected.

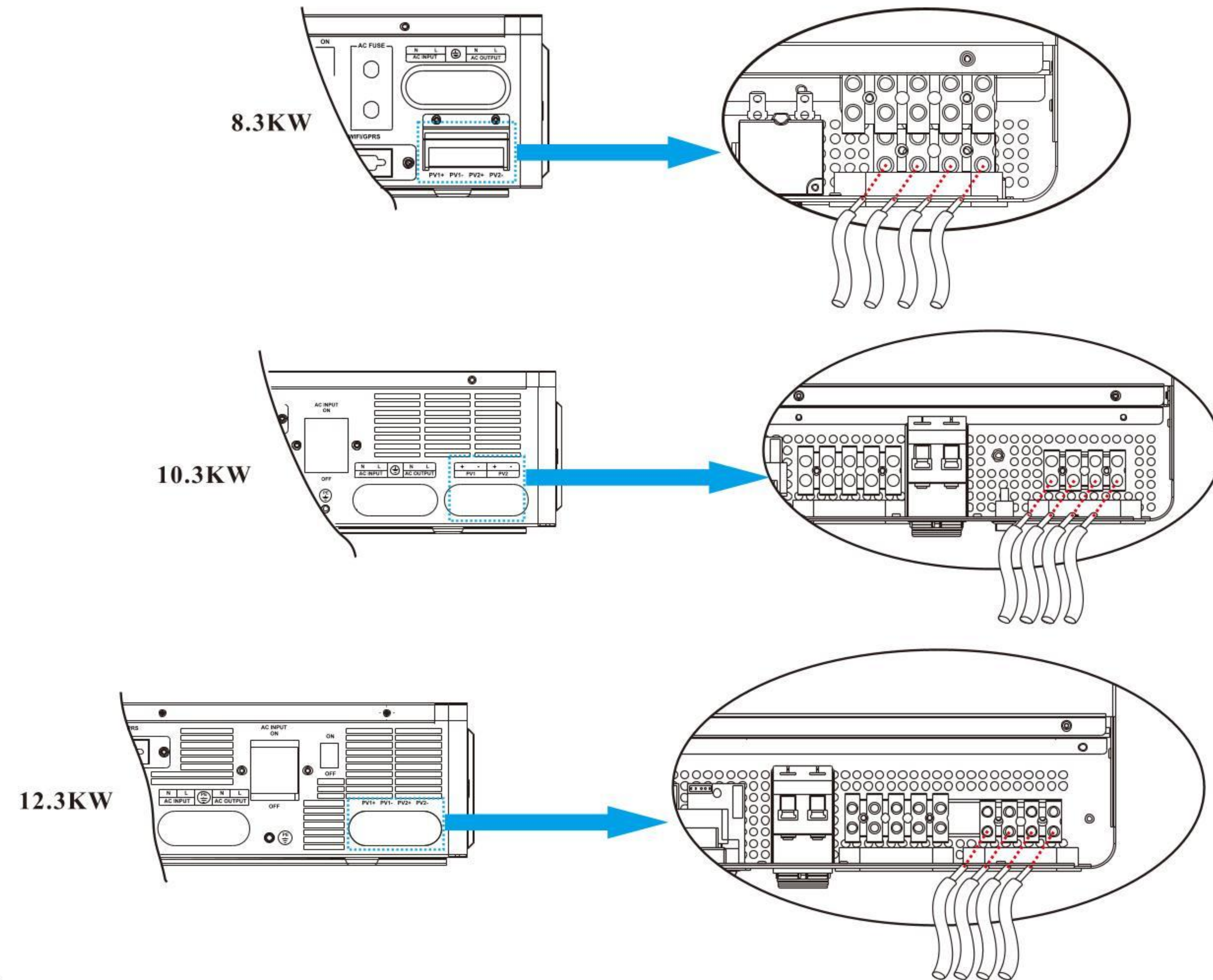

**Assembly:**

All wiring is connected, please lock the bottom cover back, see the picture below

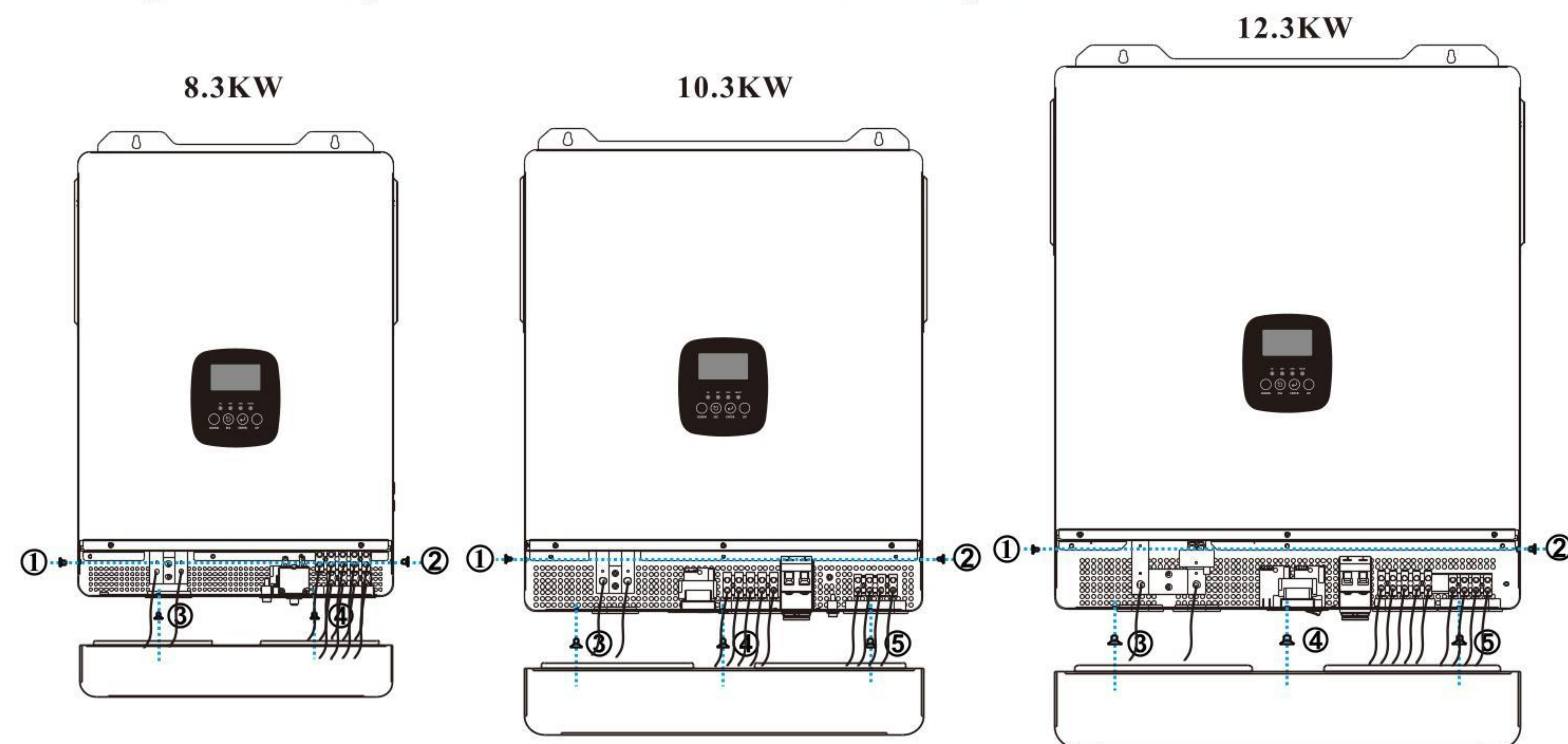

**Note :** The image shown here is indicative only. The actual product may differ.

**4. Display board Description:**

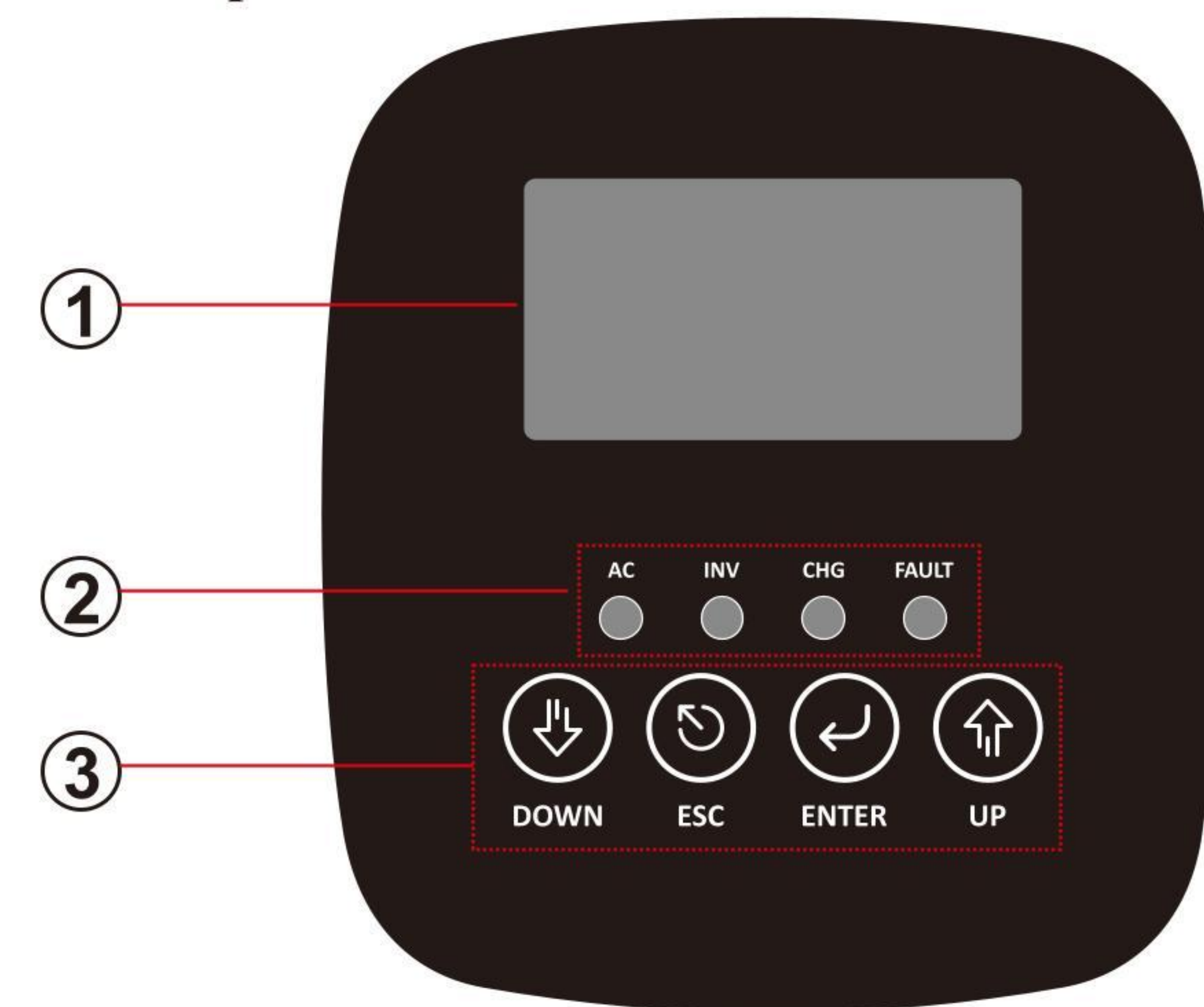

**4-1. Display control panel layout**

The display board is divided by function as shown in the figure. Divided into 3 functional areas:

- ①LCD display area, ②LED display area, ③Function key control area

**4-2. LED Indicator**

Name	Description
AC(Green)	On: The inverter works in the main state Off: Other states
INV(Green)	On: The inverter is working in the inverter state. Off: Other states
CHG (Yellow)	On: The battery is charging at float or the battery is fully charged Flashing: Battery is being charged at constant current and constant voltage Off: Other states
FLUAT (Red)	On: Inverter self-protection Flashing: Fault occurs in the inverter Off: Works normally

**4-3. Function key control area**

Four buttons:

**(UP key):** In parameter setting interface, it is numerical increase key or choose next page;

**(ESC key):** In parameter setting interface, it is exit key (exit without saving);

**(ENTER key):** Click on the display page to silence (Buzzer alarm sound is turned off), press and hold for 3 seconds to enter the setting page; Click on the settings page to enter parameter changes, long press for 3 seconds to save parameters and exit;

**(DOWN key):** In parameter setting interface, it is numerical decrease key or the previous page.

**4-4. On/off key area**

This switch is self-locking switch; Press the switch to turn on (activate AC output and charging), and Press the switch again and it will pop up to turn off (turn off AC output and charging). (When the switch is not pressed, if photovoltaic is connected at this time, the inverter will also start battery charging but no AC output).

#### 4-5. LCD screen description

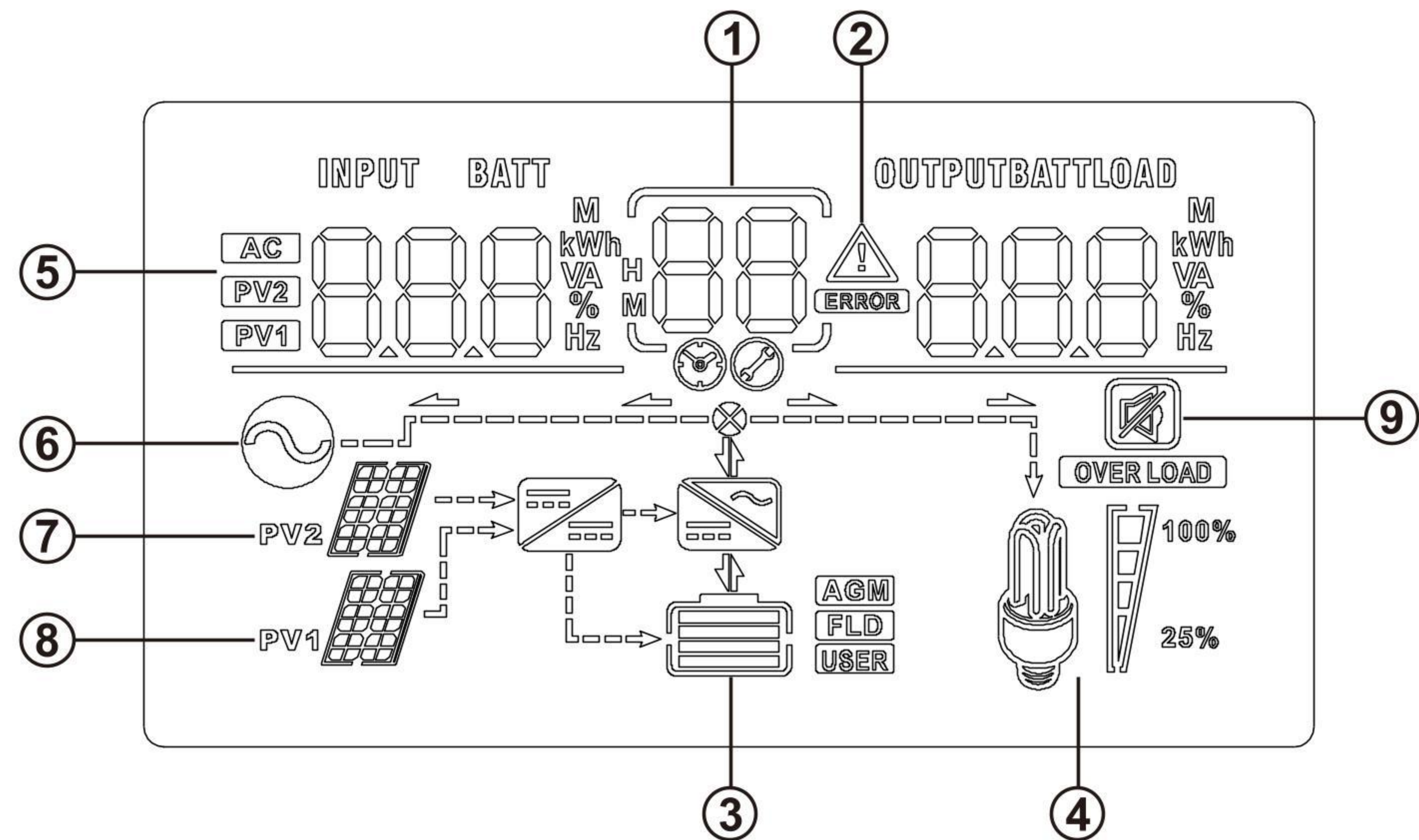

#### 1) LCD Display include icon display, working status display area, numerical display and function setting area.

1 Page number and fault code display icon	2 Fault icon	3 Battery capacity display
4 Load percentage display	5 Numeric display and function display area	
6 Mains icon	7 PV2 icon	8 PV1 icon
		9 Mute icon

##### a. Icon display:

- Load and battery icons indicate the load and battery capacity. Each square represents 25% of the capacity.
- Mute icon shows whether the buzzer is muted. Under normal circumstances, this icon is not displayed: press the ENTER key in any mode.

The inverter enters the mute state and the buzzer inhibit icon will be displayed.

- Fault icon only display when in fault mode, and won't display in other situations.

##### b. Working status display area:

- After starting up, this display area mainly displays working status of inverter, such as mains status, inverter status, grid connection status, etc.

##### c. Numerical display and function setting area:

- In non-function setting mode, this area displays inverter related information. Normal mode displays output information, check the operation up and down. Inquiry key (UP or DOWN key) is used to display input voltage and output voltage, input frequency and output frequency, battery voltage and current, PV voltage and PV current, PV voltage and power, output power and output voltage, output apparent power and output Voltage, load percentage and output voltage related information. The fault mode displays the fault code.

- In function setting page, you can set the working mode, battery high and low voltage alarm, etc. by operating the ENTER key and the UP and DOWN keys

#### 2) On and off operation

Please refer to this manual for power on/off operations.

##### a. Switch on steps

The power-on operation can be performed when a battery or mains power that meets the requirements is connected (the mains power needs to confirm a reasonable input range according to the output mode) or a PV that meets the requirements is connected.

- Mains power on

Connect to normal mains power, press the switch to ON state, system will boot. If set to mains output priority, wait for while, the screen will display mains mode to indicate that the startup is completed and inverter is in the mains mode.

- Battery powered on

Connect with normal battery, press the switch, and the inverter establishes working power. The system will automatically turn on. After waiting for a while, the screen will display battery mode to indicate that the startup is complete and inverter is in battery mode.

##### b Switch off steps

When inverter is in battery mode or mains mode output, if you press the switch again, the switch will pop up and inverter will shut down.

##### c Operations under alarm status

When inverter has an alarm sound and the LED fault light flashes, it means that inverter is working in an alarm state. Please check the cause of the alarm based on the alarm information or contact the supplier.

#### 4-6. Introduction to the display interface (main display interface)

**Display page 00) output priority (GRD: mains output priority; PV: photovoltaic output priority; PBG: battery output priority) and inverter working status (INV: inverter power supply, REC: mains charging, GRD: main+pv hybrid complementary power supply, GRE: On grid feed power supply, UTI: mains bypass power supply)**

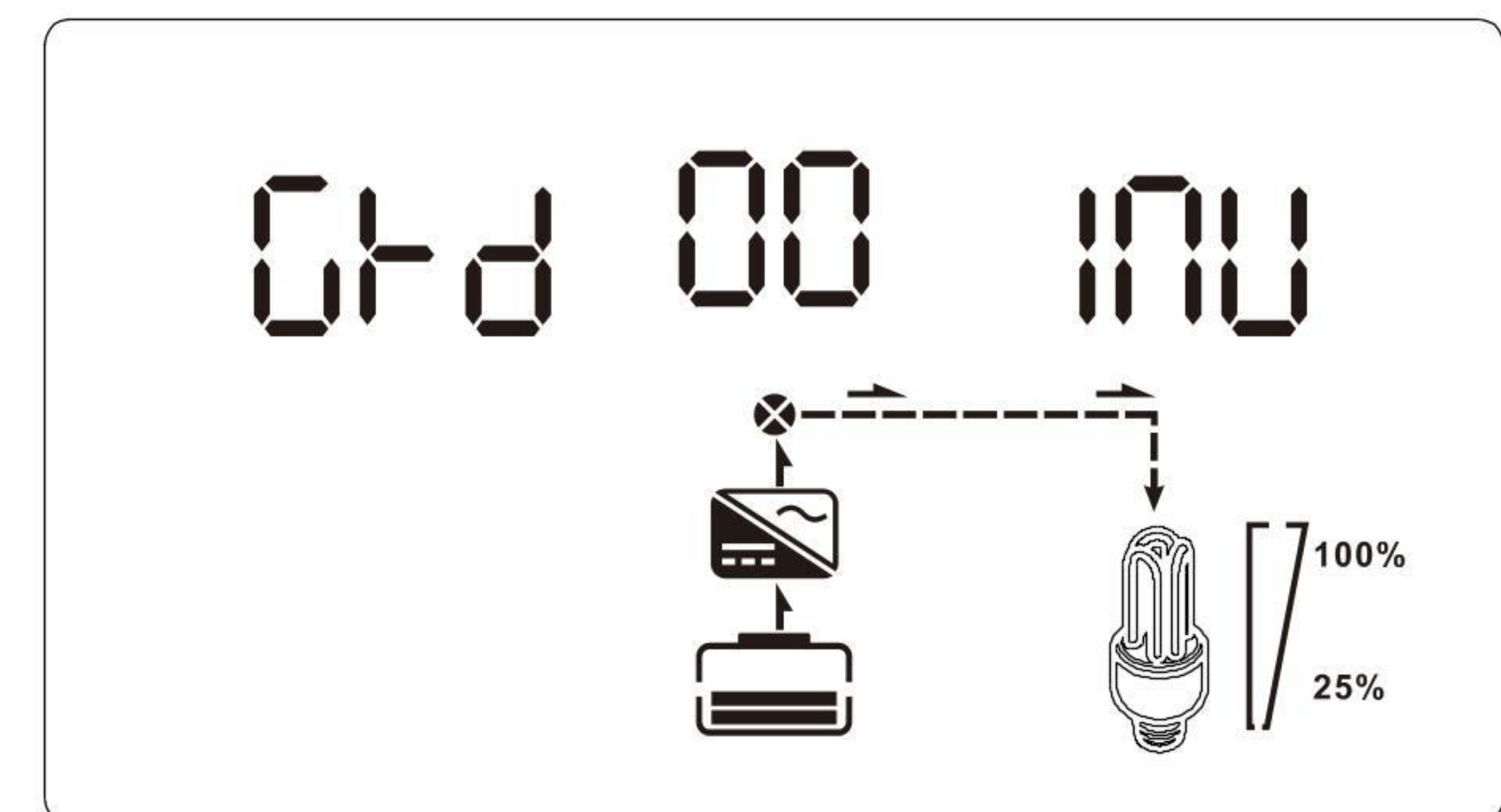

Page 01) AC Output voltage & frequency

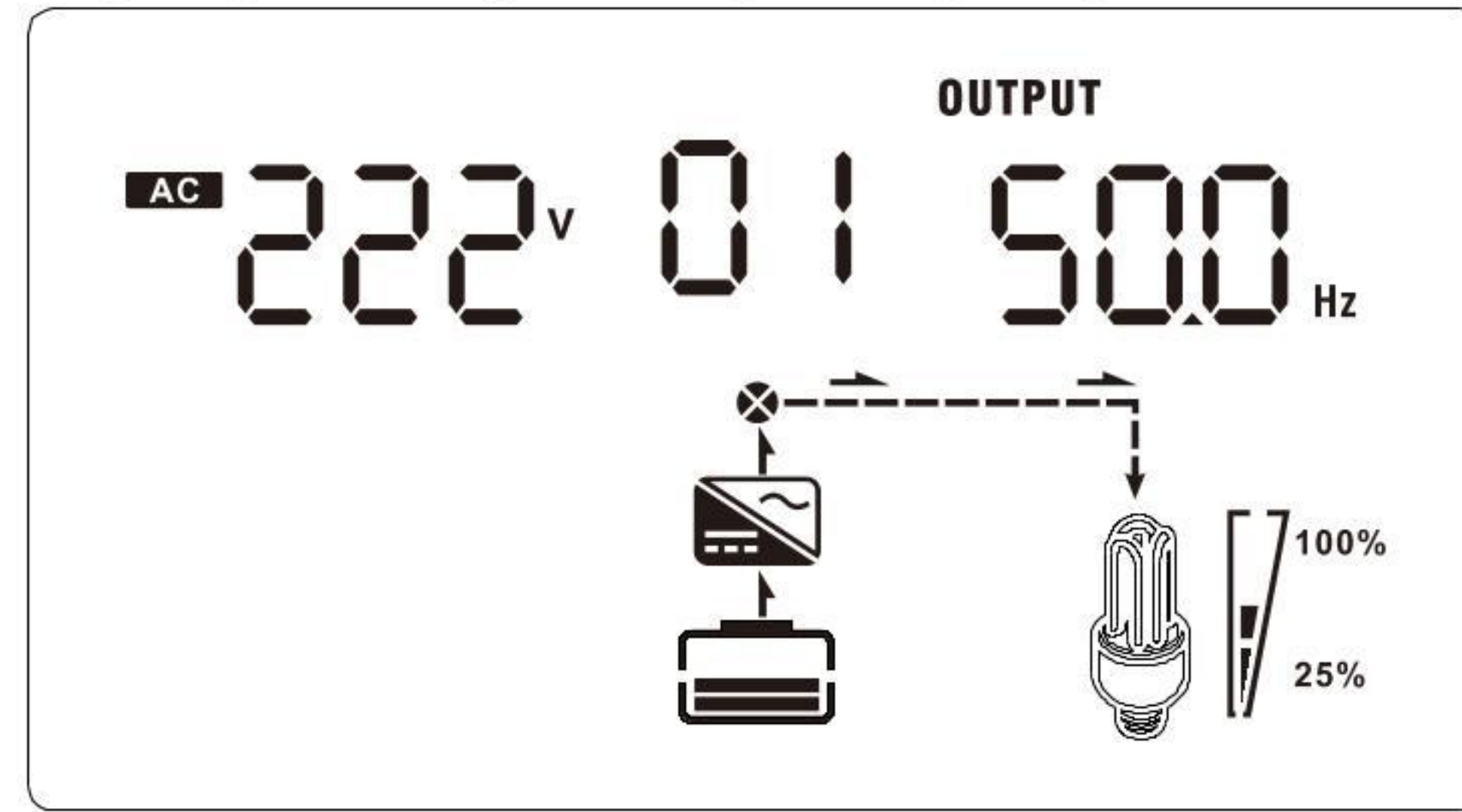

Page 02) AC Input voltage & frequency

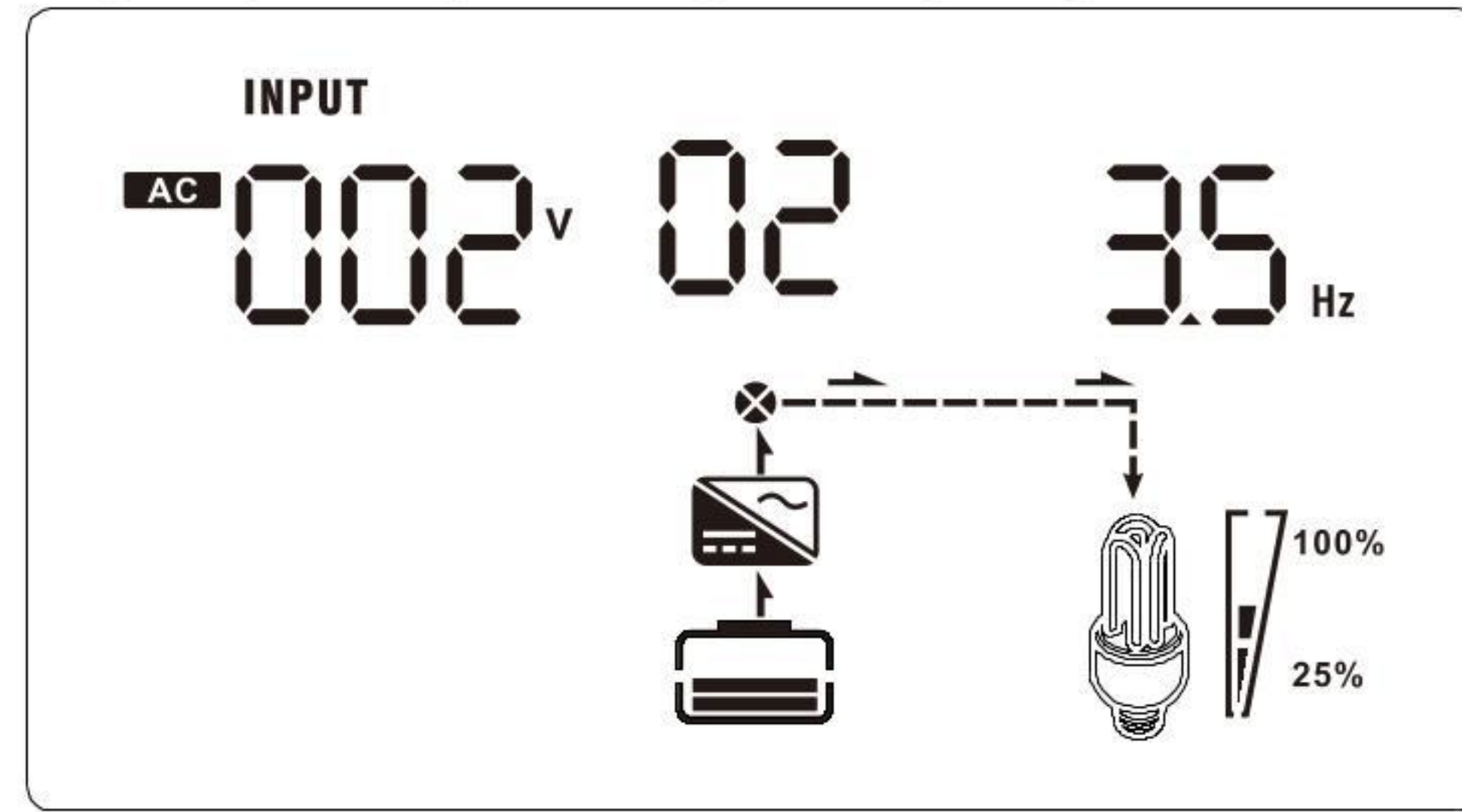

Page 03) Battery voltage & current

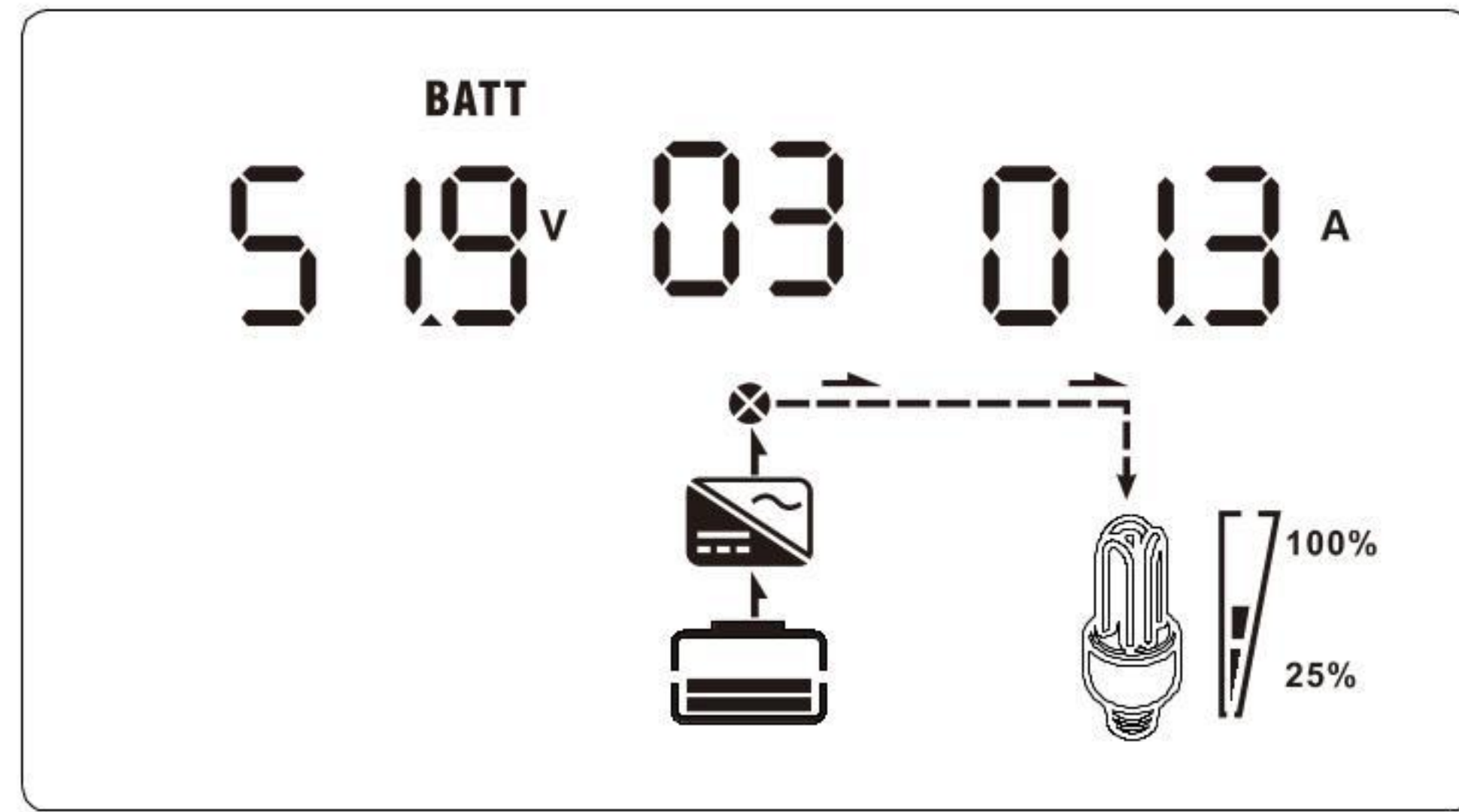

Page 04) Battery discharge power & discharge capacity

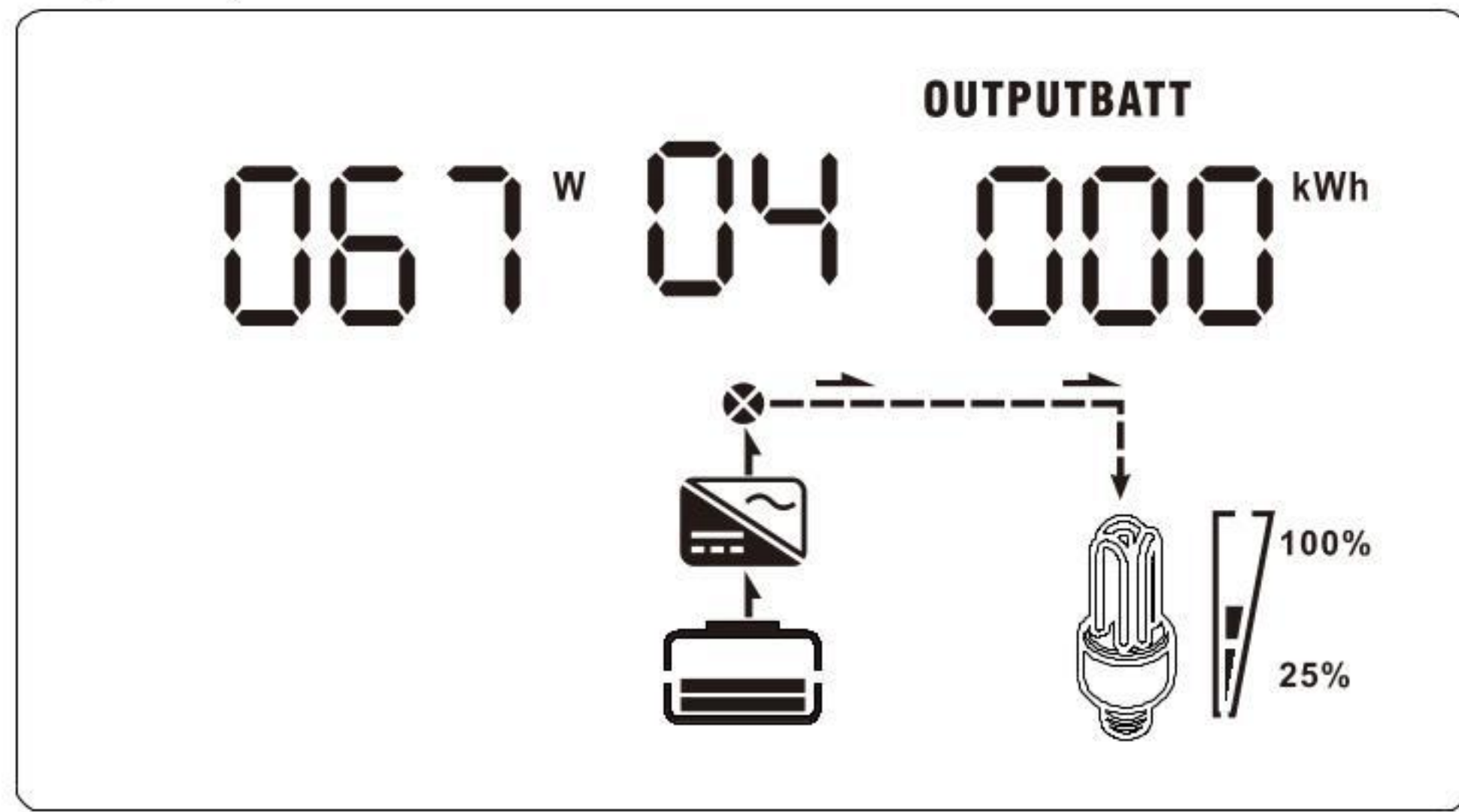

Page 05) Battery charge power & charge capacity

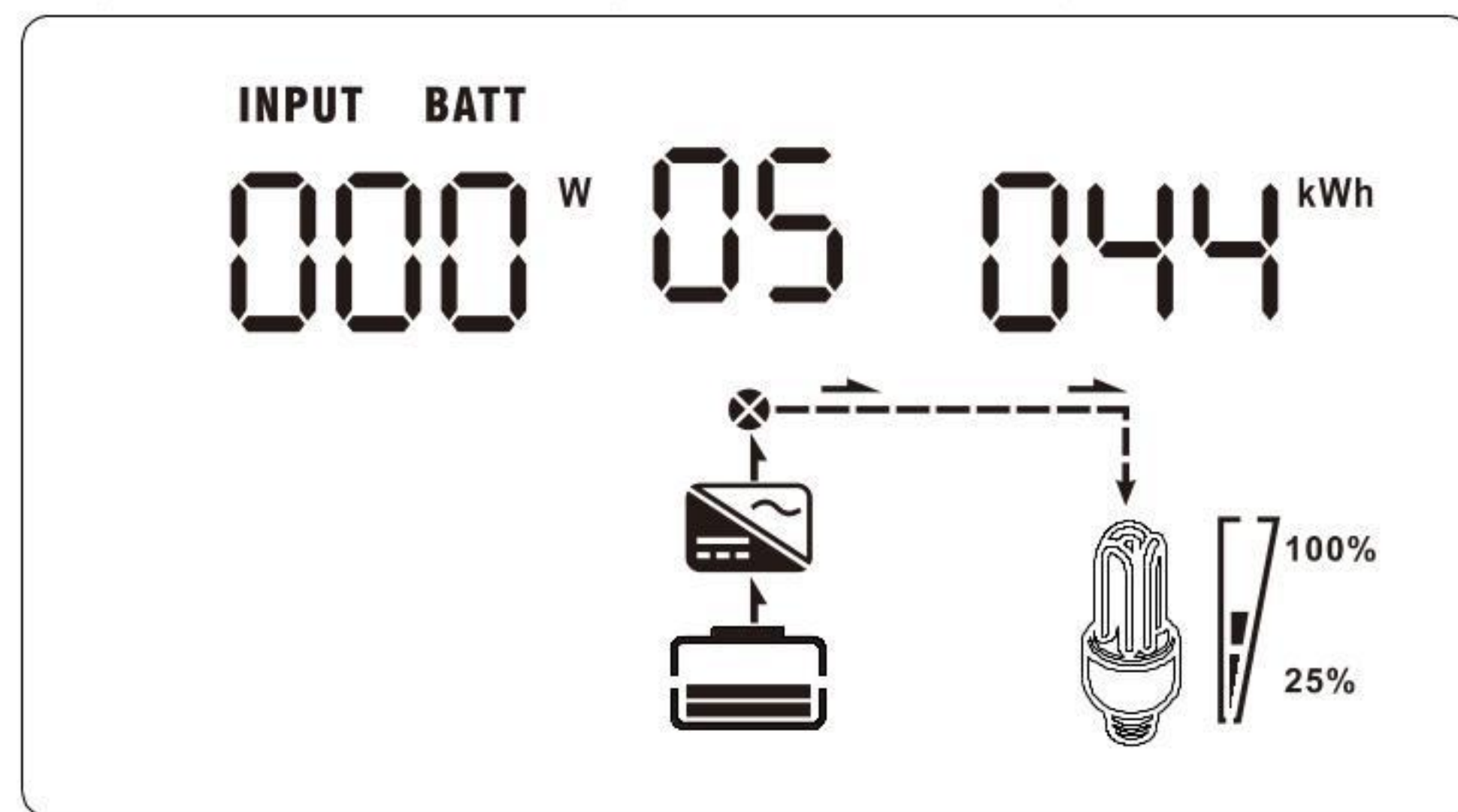

Page 06) Battery power percentage and remaining battery capacity  
(Note: The remaining battery capacity is only available when GRD, VLO and PAC lithium battery communication protocols are selected in Setting A16 and successfully connected to lithium batteries.)

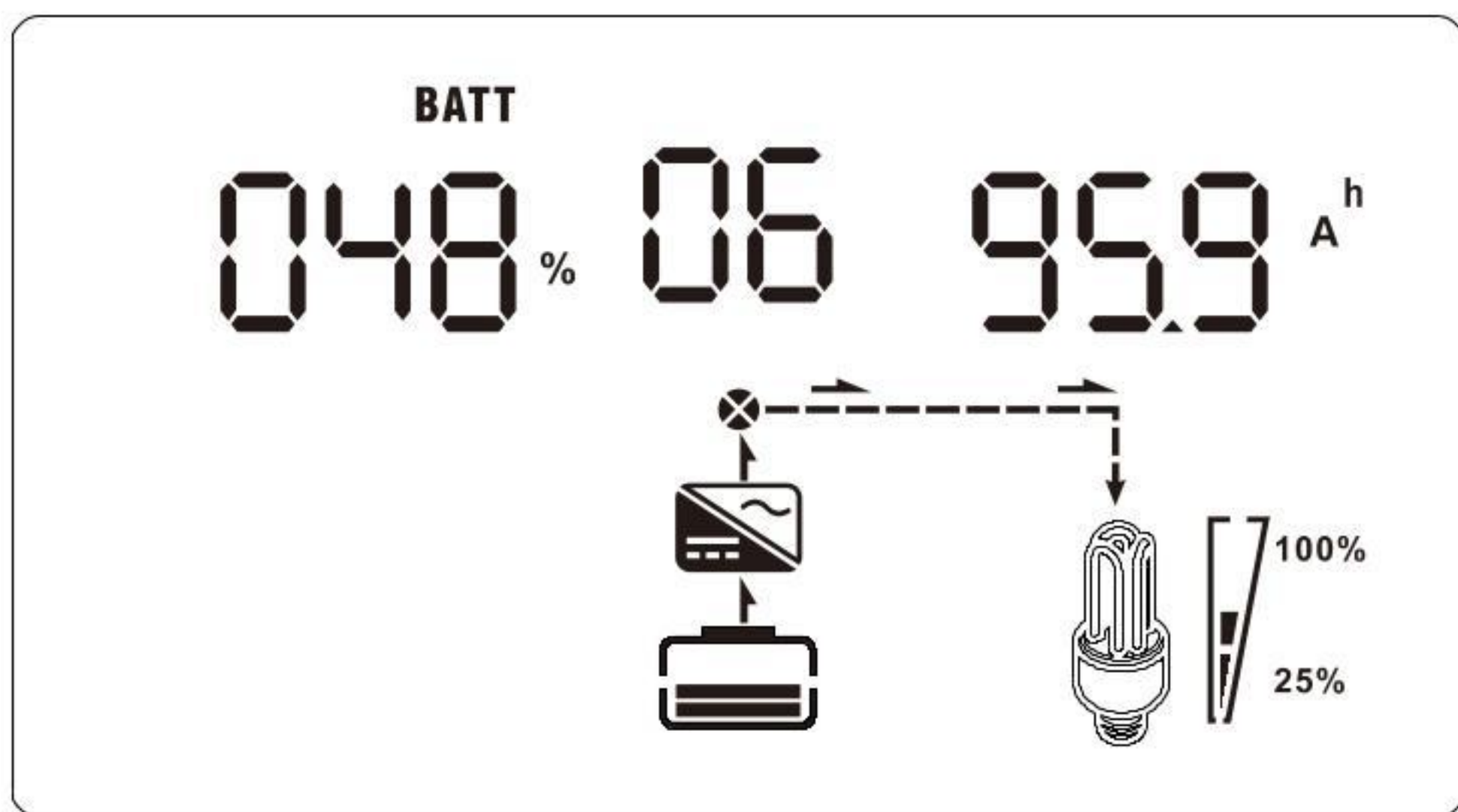

Page 07) Inverter inner BUS voltage & BUS current

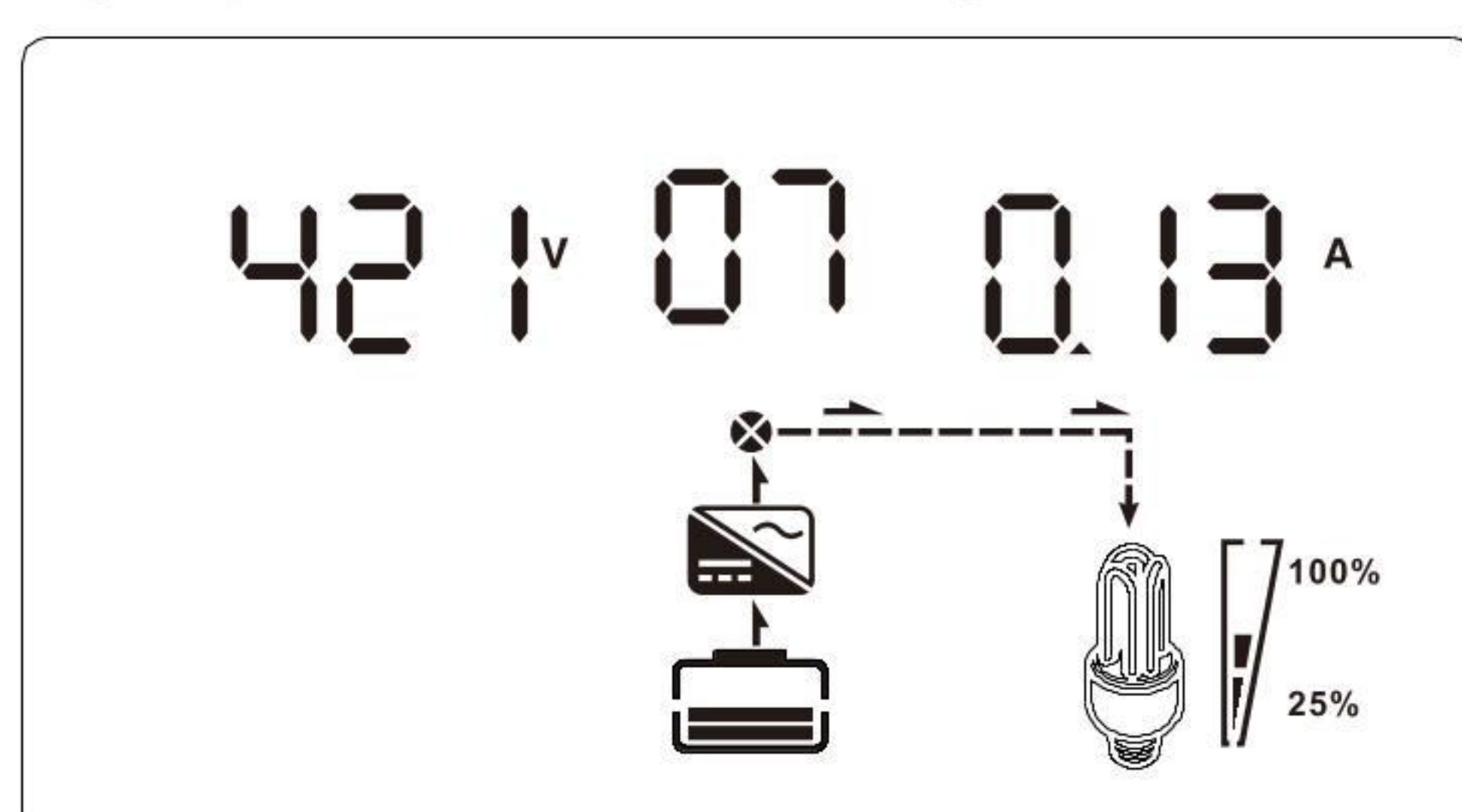

Page 08) AC input current & inverter inner convert current

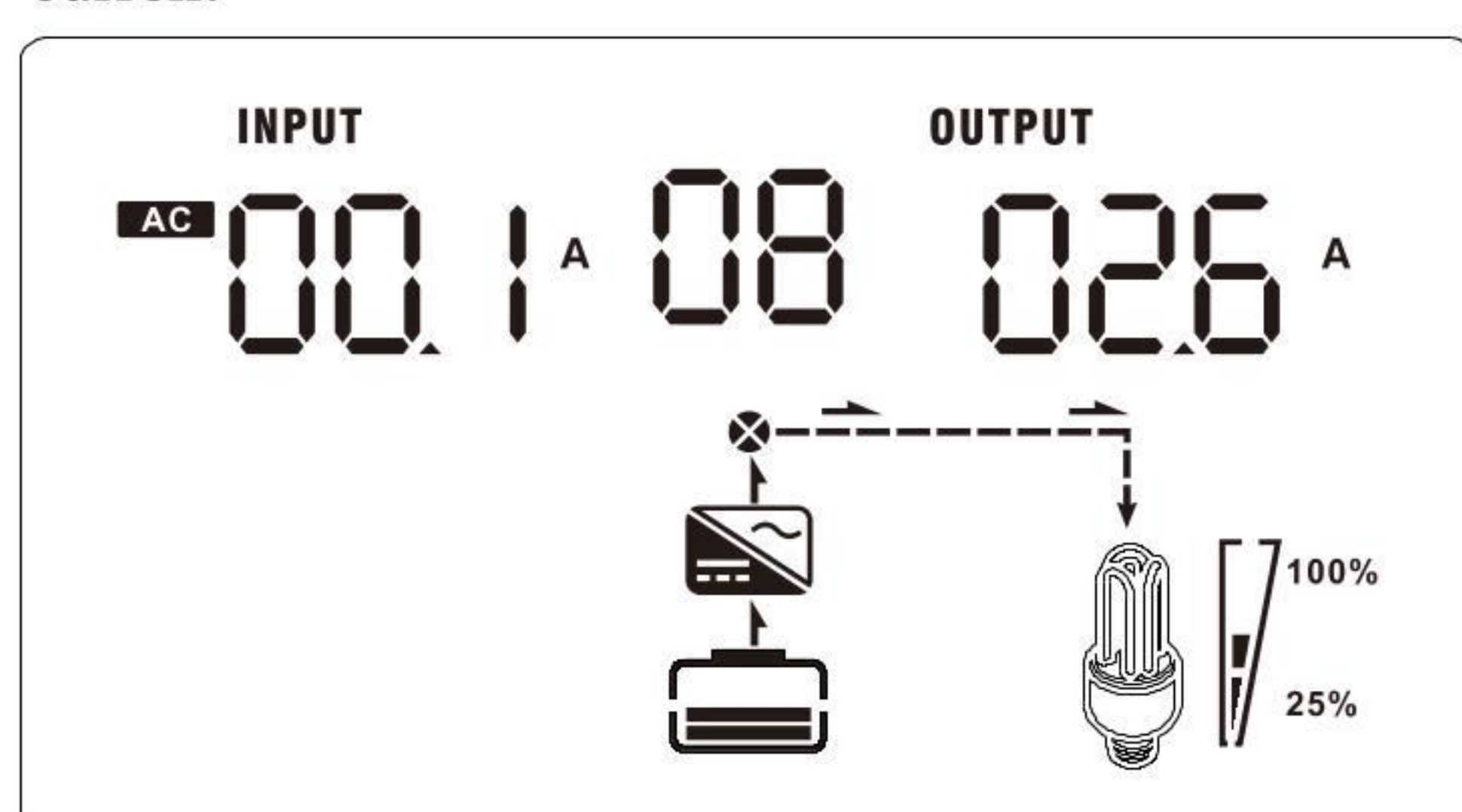

Page 09) Grid tie power & generation

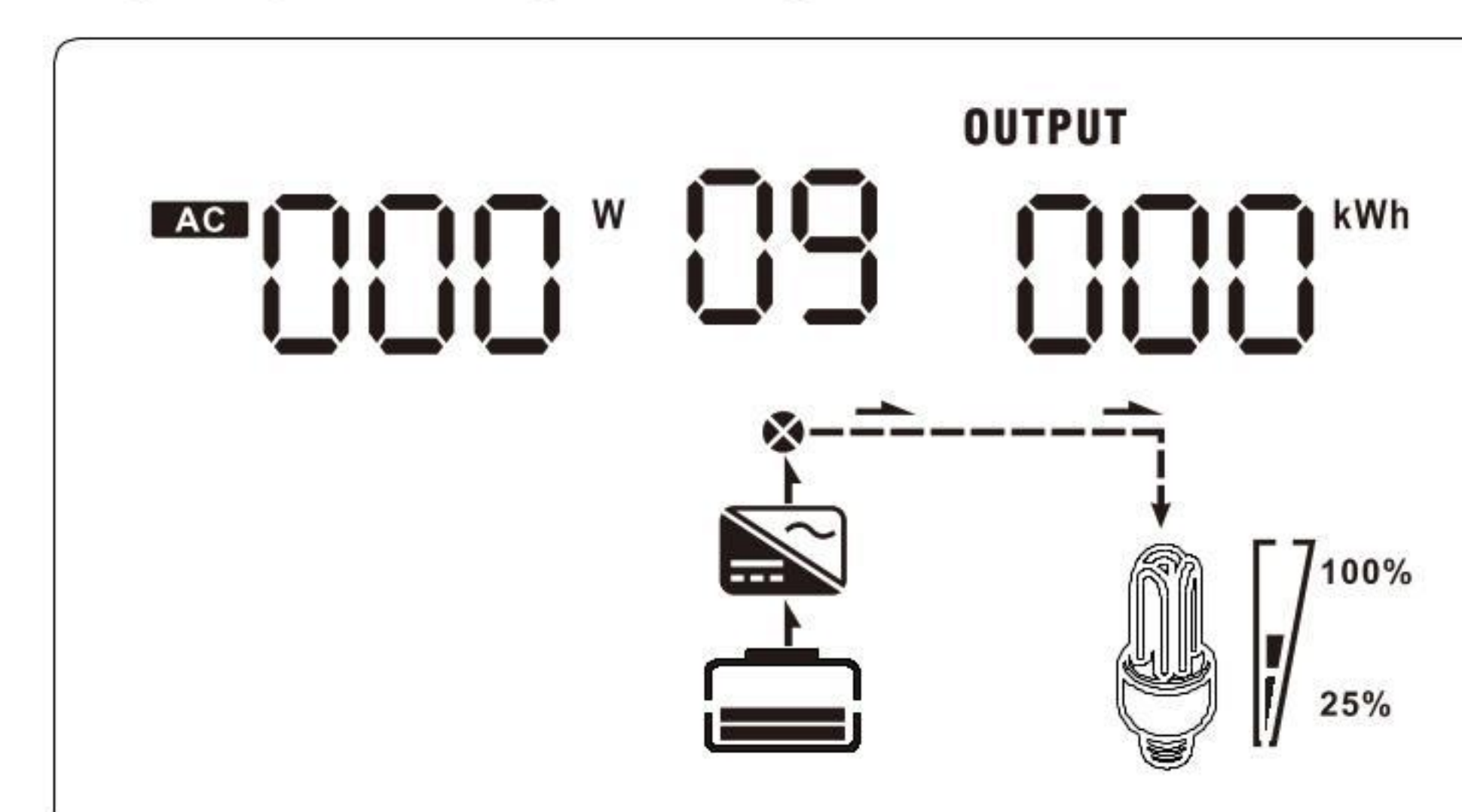

Page 10) AC Input power & Generation

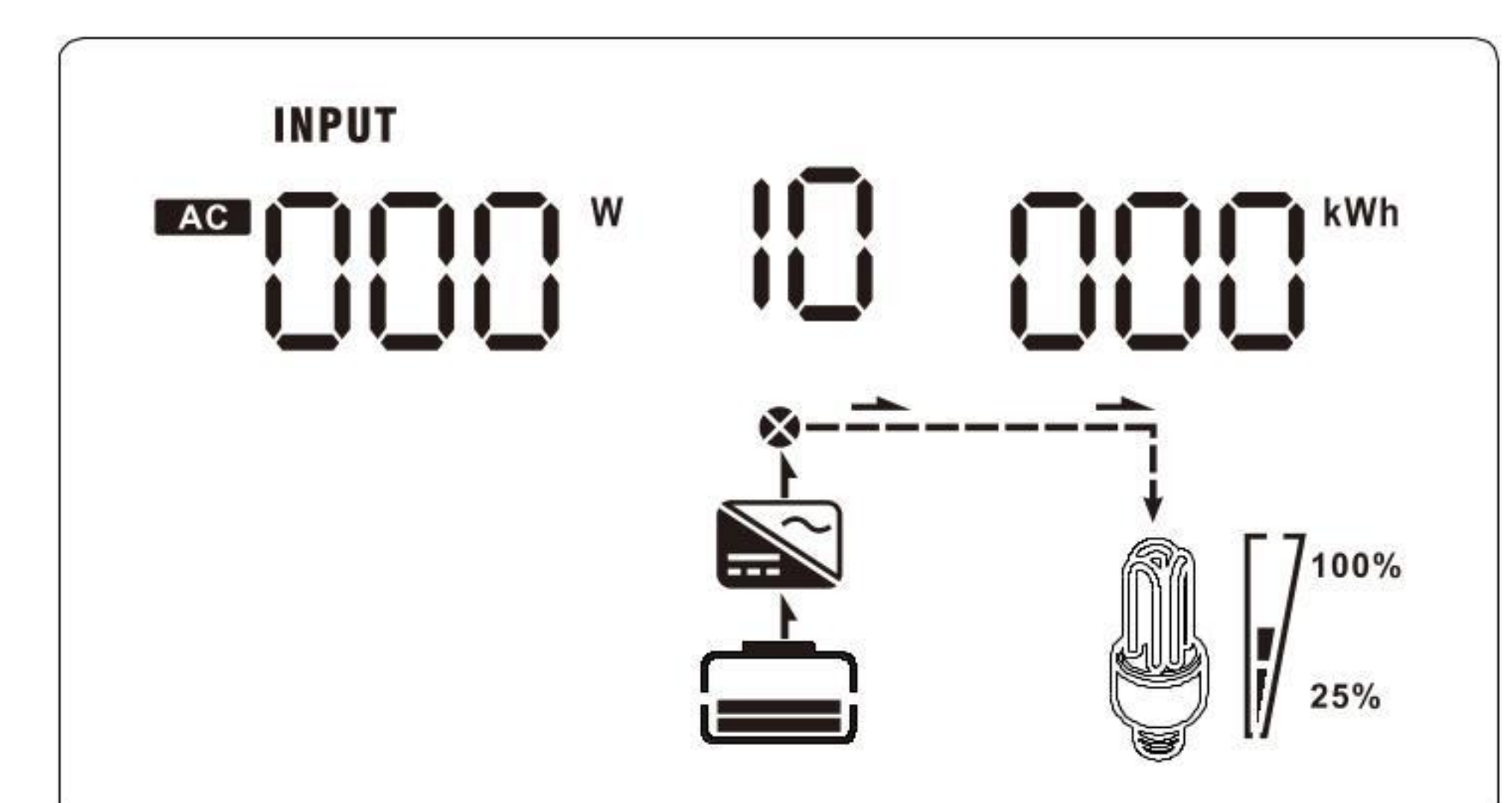

Page 11) AC charging power & electricity

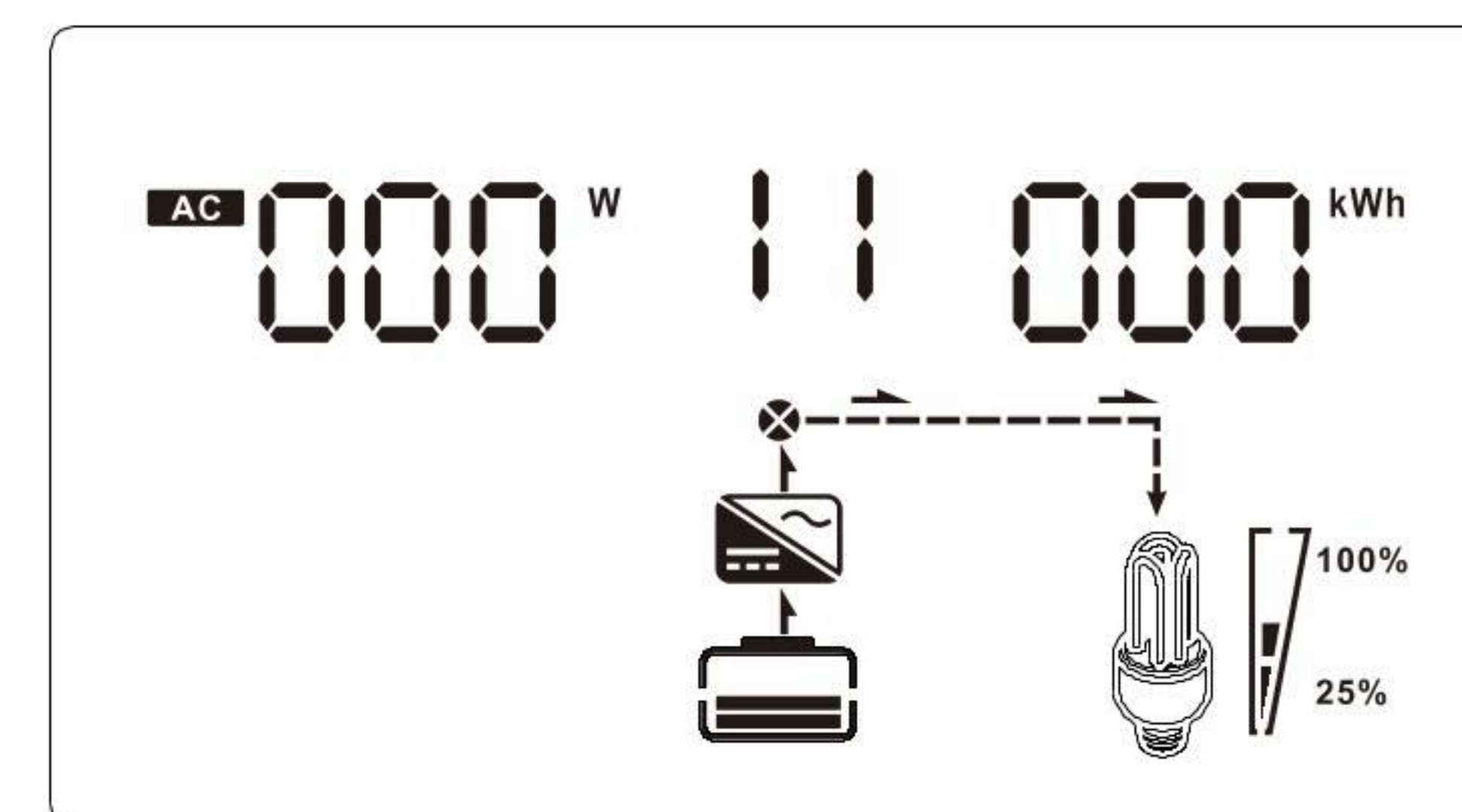

Page 12) Loads power & Loads power percentage

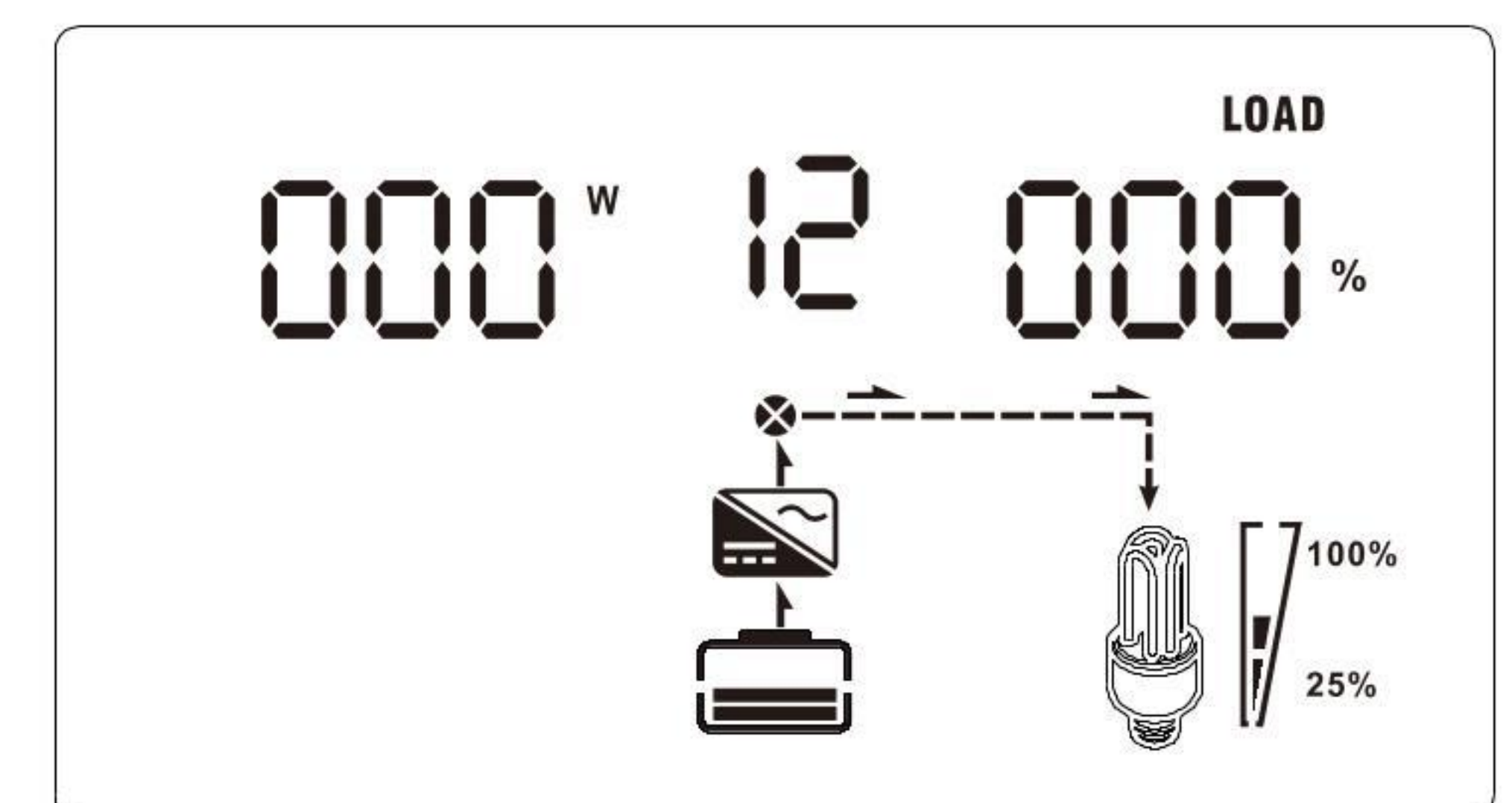

Page 13) Loads electricity & current

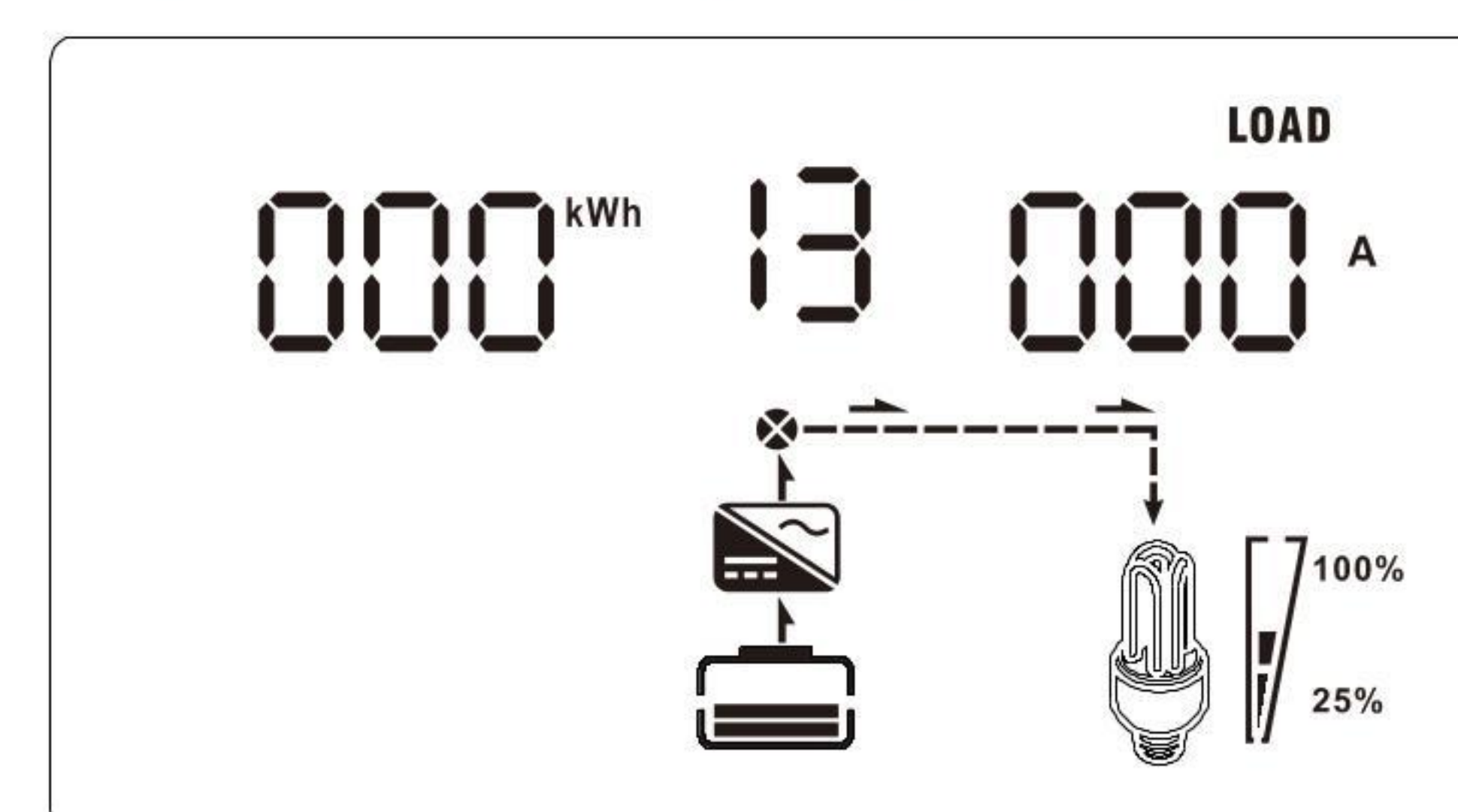

Page 14) PV1 voltage & PV1 current

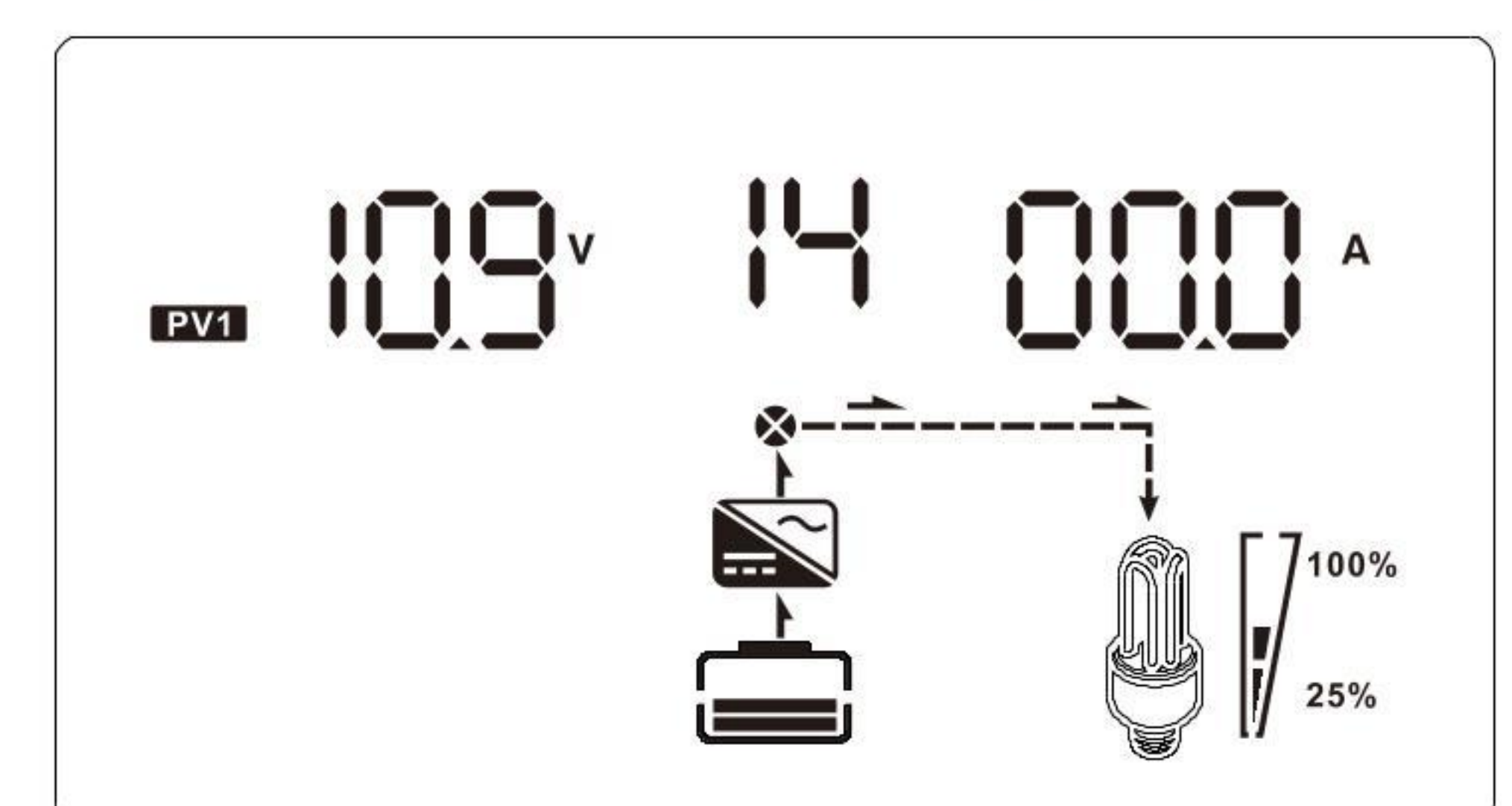

Page 15) PV1 Power and PV1 Generation

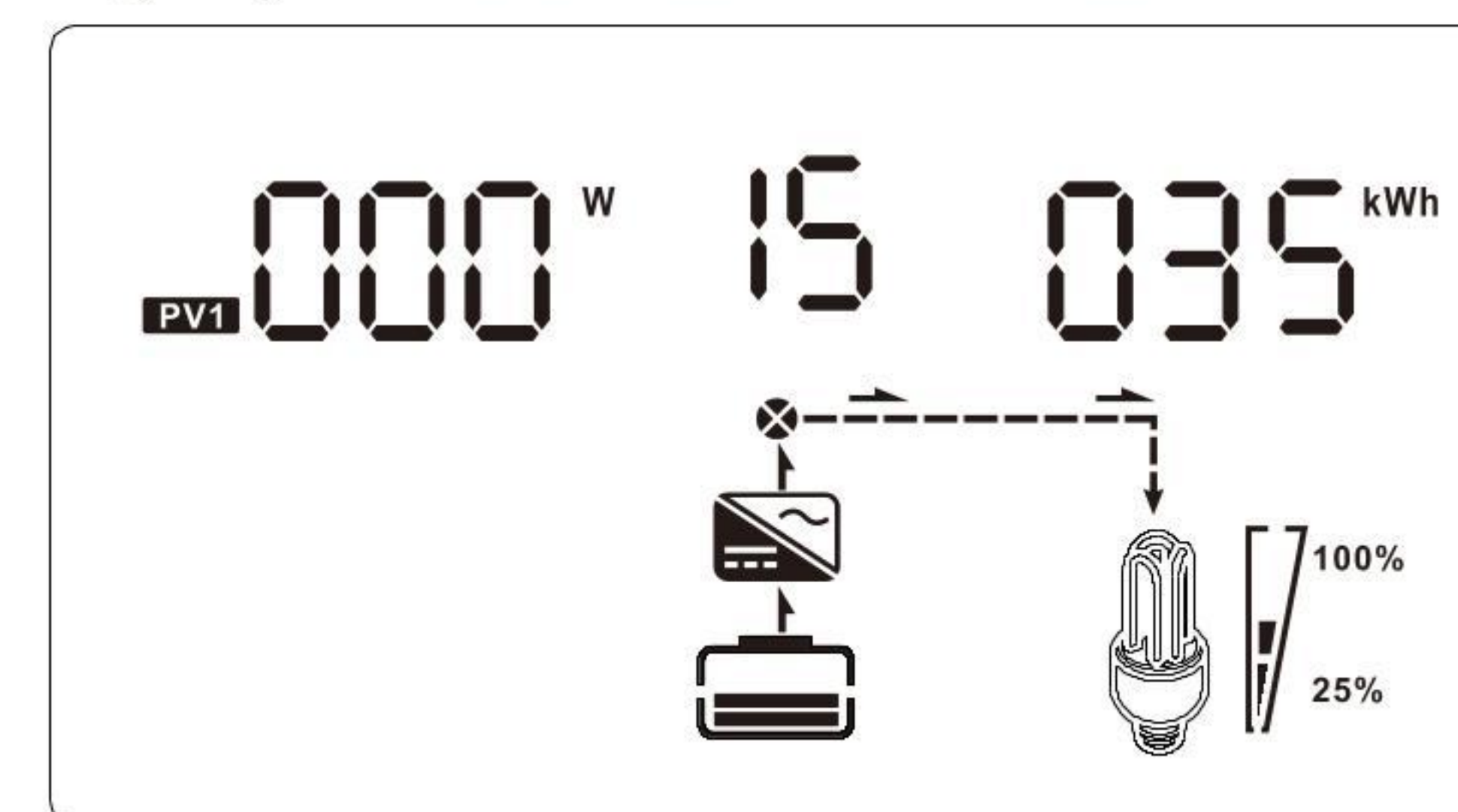

Page 16) PV2 voltage & PV2 current (Note: This page is not displayed for 3.3KW/4.3kw/6.3KW models)

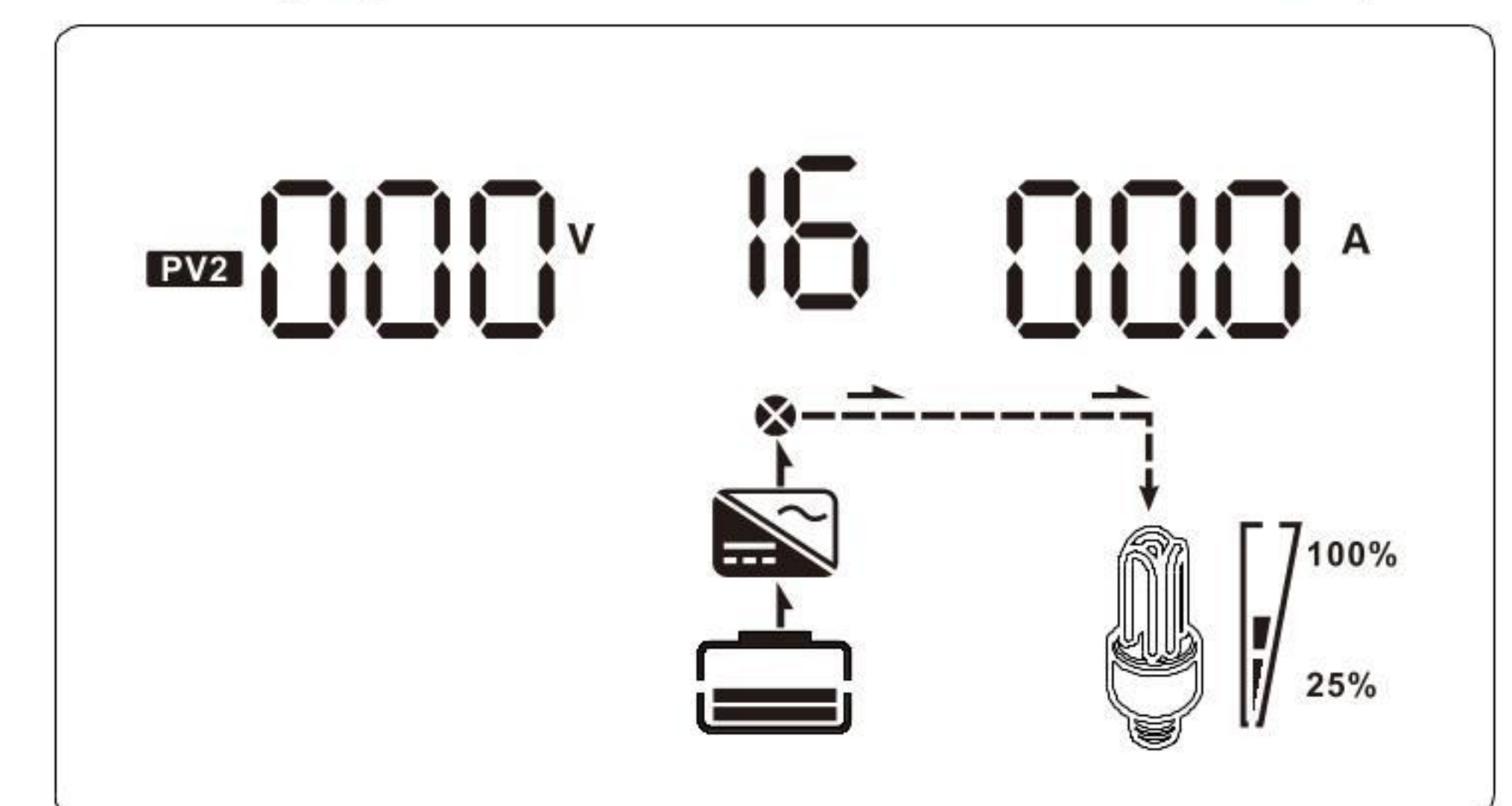

Page 17) PV2 Power and PV2 Generation (Note: This page is not displayed for 3.3KW/4.3kw/6.3KW models)

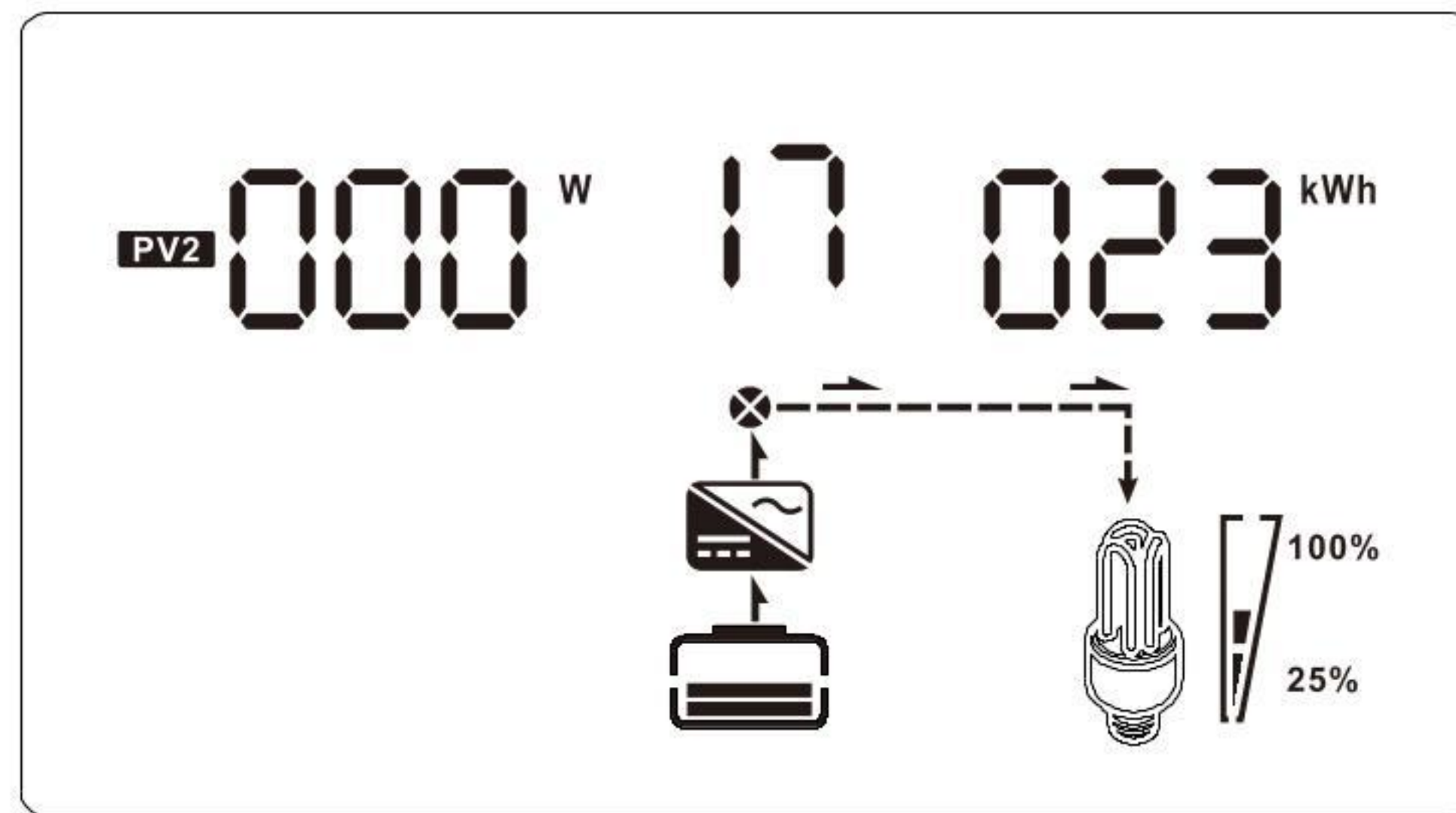

Page 18) Host computer (Note: This data for 3.3KW/4.3kw/6.3KW models is displayed on page 16)

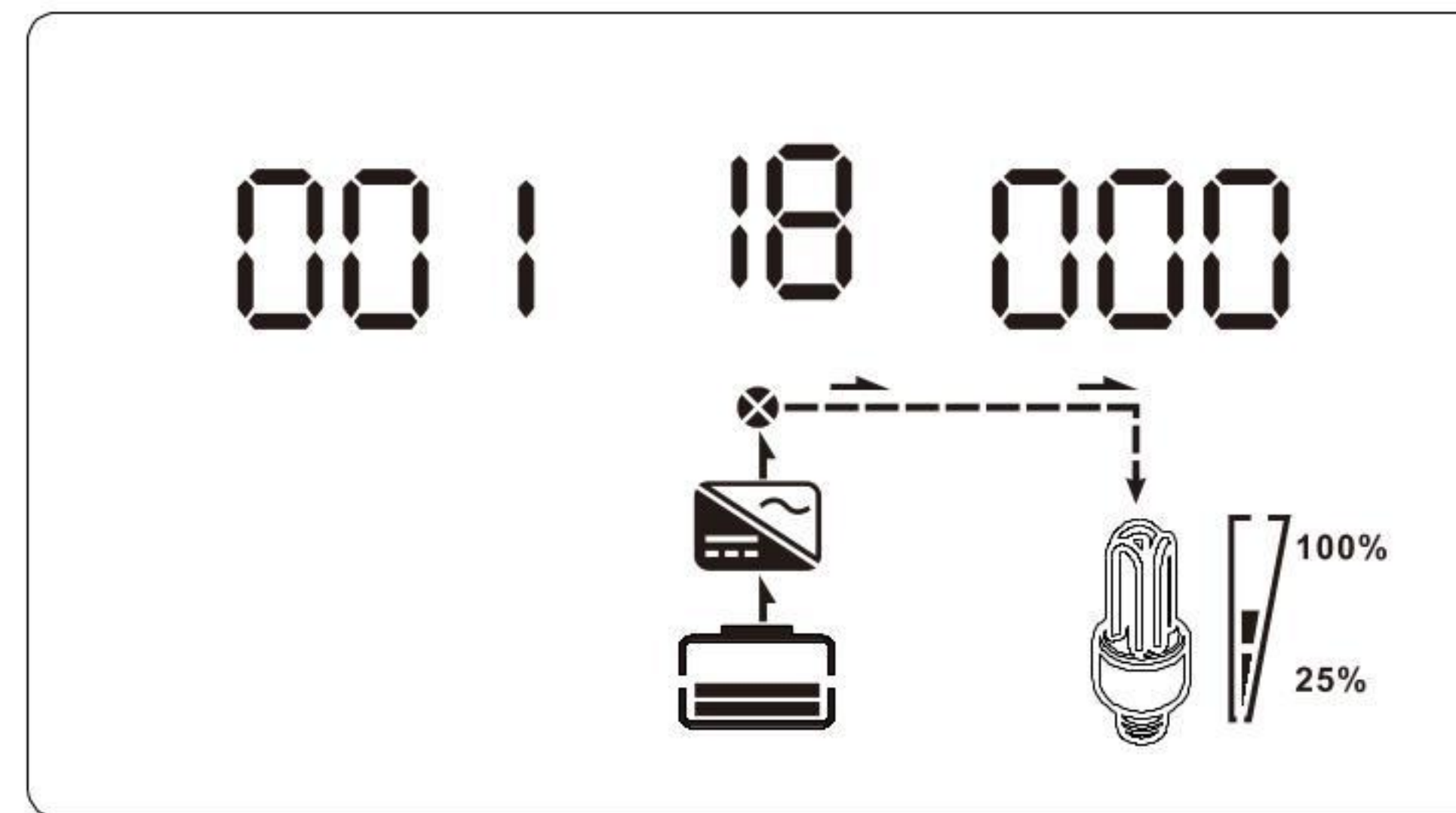

Page 19) Inverter Internal MPPT Heat Sink Temperature and Inverter Heat Sink Temperature (Note: This data for 3.3KW/4.3kw/6.3KW models is displayed on page 17)

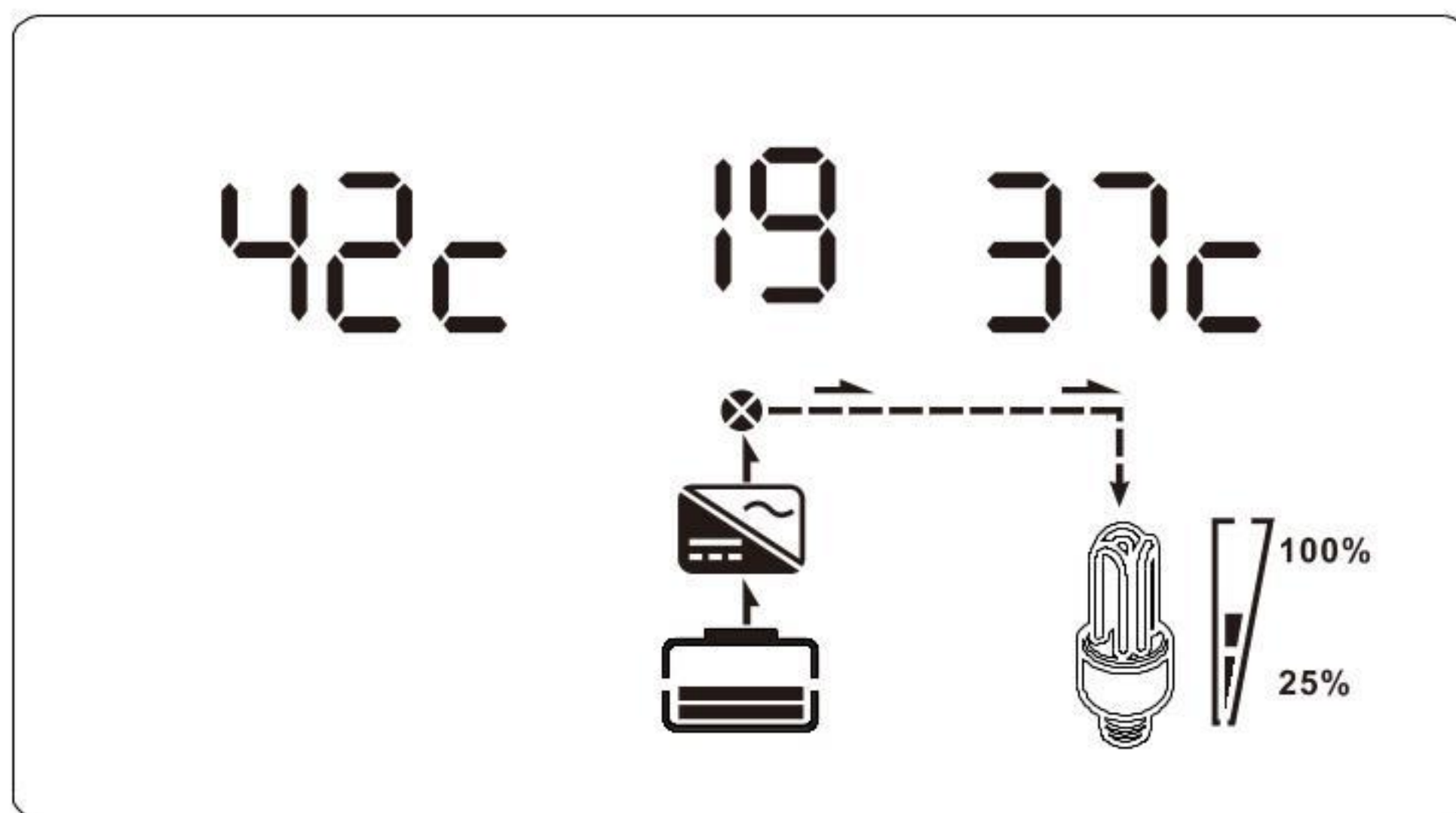

Page 20) Inverter Internal DC/DC Heat Sink Temperature and Software Version Number (Note: This data for 3.3 KW/4.3kw/6.3KW models is displayed on page 18)

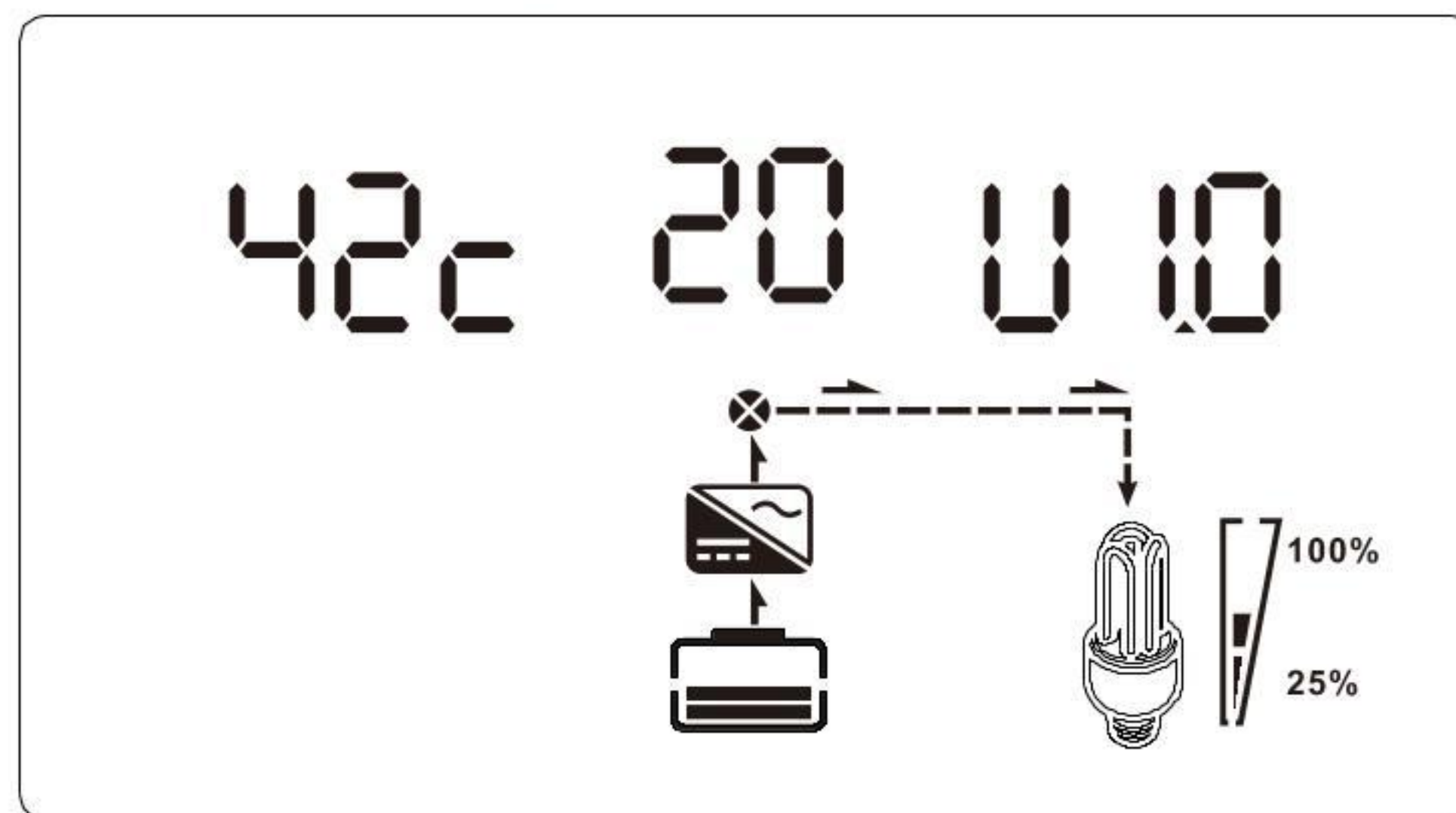

**Note: 3.3KW/4.3KW/6.3KW models have only one PV input, that is, no PV2, so pages 16 and 17 are not displayed, and pages 18, 19, and 20 will be moved forward two pages.**

#### 4-7. Function Setting Operation

Enter the exit function setting page and function setting specific operation as follows.:

- Press ENTER 2 seconds to enter the function setting page, Press UP key or DOWN key for 0.1 to 2 seconds to select the function, after turning the page to the desired function setting page, the corresponding function words will blink.
- Press ENTER for 0.1 to 2 seconds to enter the setting page of the selected function, at this time, the words of the selected function will light up, and the value will blink to the right of the words of the selected function. The selected function will be illuminated and the value of the selected function will be flashing on the right side of the word. Press the UP or DOWN key for 0.1 to 2 seconds to select the value of the desired function parameter.
- After turning the page to the required function parameter, press ENTER for 0.1 to 2 seconds, setting is completed, then the function parameter number is long lit and no longer flashing. The function setting is completed, and the number of function parameters will not flash anymore, then you can continue to set other functions.
- Finally press the ENTER key for more than 2 seconds before the function is set successfully, and at the same time exit the function setting page and return to the main display page. (You can also click the ESC key for 0.1 to 2 seconds without saving to return to the main display page.)

#### 1) Output priority setting (A0)

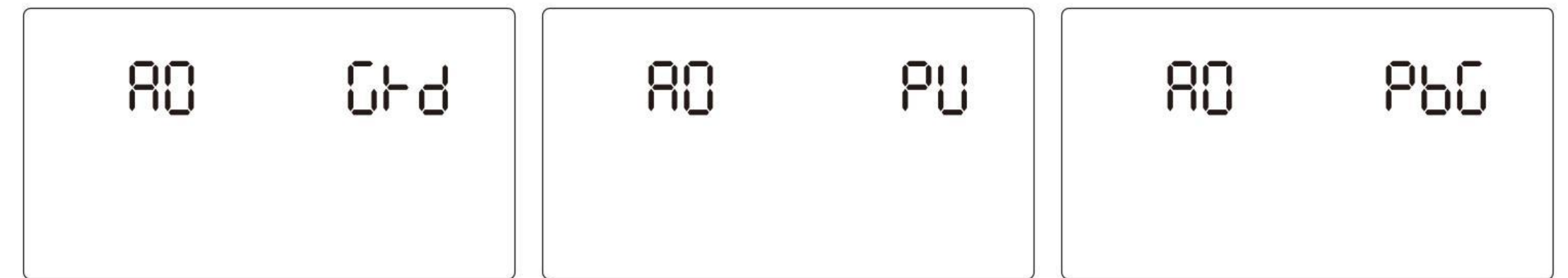

Function Set the output priority of the inverter

Note: There are three choices, the default is GRD: Mains priority, PV: PV priority, PBG: battery priority. It can only be set in the battery mode, and takes effect immediately after the setting is saved.

- Press ENTER for more than 2 seconds to enter the function setting page, Press UP key or DOWN key for 0.1 to 2 seconds to select the function, after turning the page to A0 output priority setting page, the word A0 will flash.
- Press ENTER for 0.1 to 2 seconds to enter the setting page of A0 output priority, at this time, the word A0 is long lit and the right side of the word A0 letters blink on the right side of A0. Press UP key or DOWN key for 0.1 to 2 seconds to select different output priority, the available output priority are GRD: Utility output priority / PV: Photovoltaic output priority / PBG: Battery output priority.
- After turning the page to the desired output priority, press the ENTER key for 0.1 to 2 seconds, the output priority setting is completed, at this time A0 The letter on the right side is long lit and no longer blinks.
- Finally press ENTER for more than 2 seconds before the function is set successfully to exit the function setting page and return to the main display page.

#### 2) Average charge voltage setting (A1)

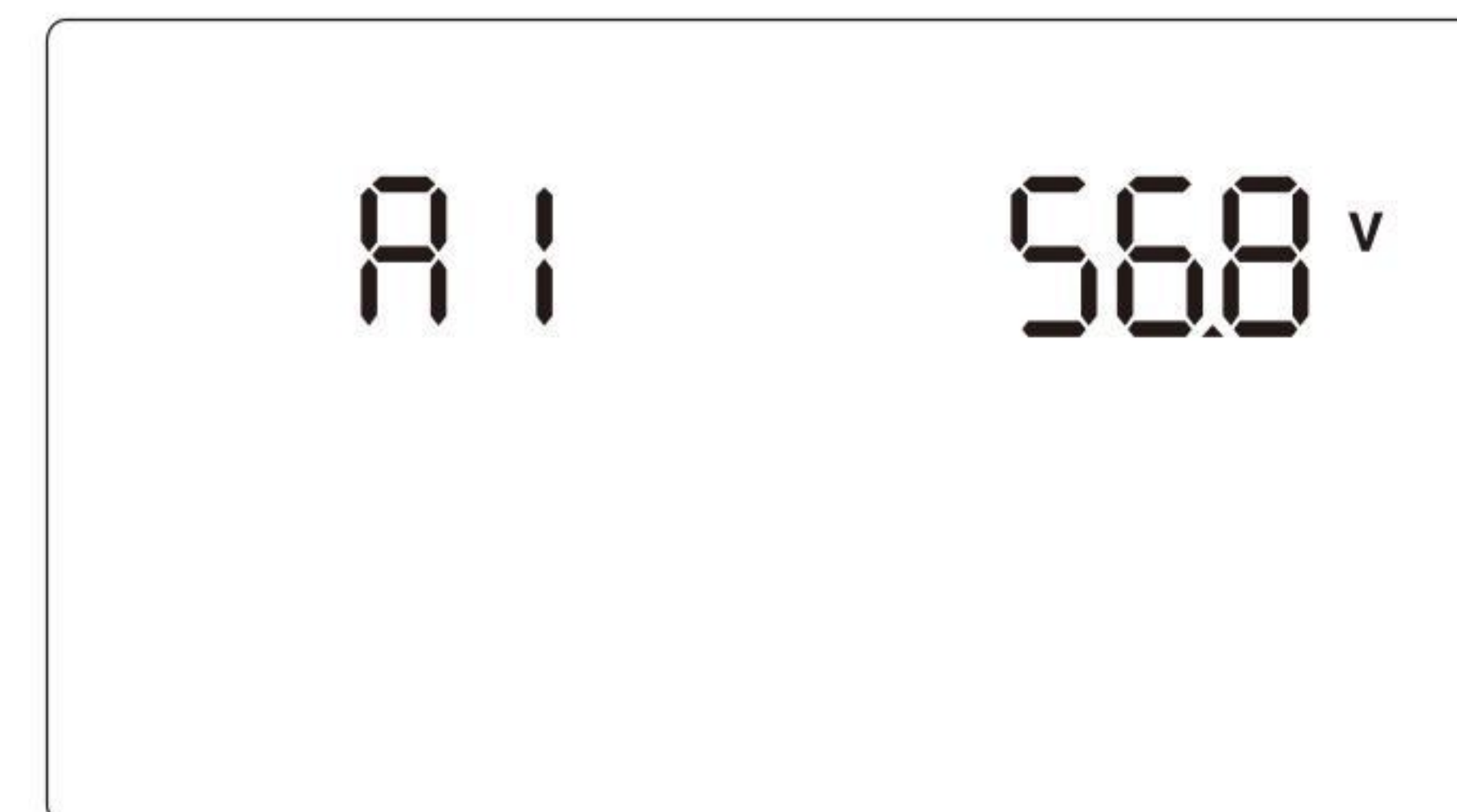

Function description: Average charge voltage setting. All working modes can be set, it takes effect immediately after setting is saved.

Noted:

48V Model: 48.0V~62.0V can be set, default is 56.8V;  
24V Model: 24.0V~31.0V can be set, default is 28.4V.

#### 3) Float voltage setting (A2)

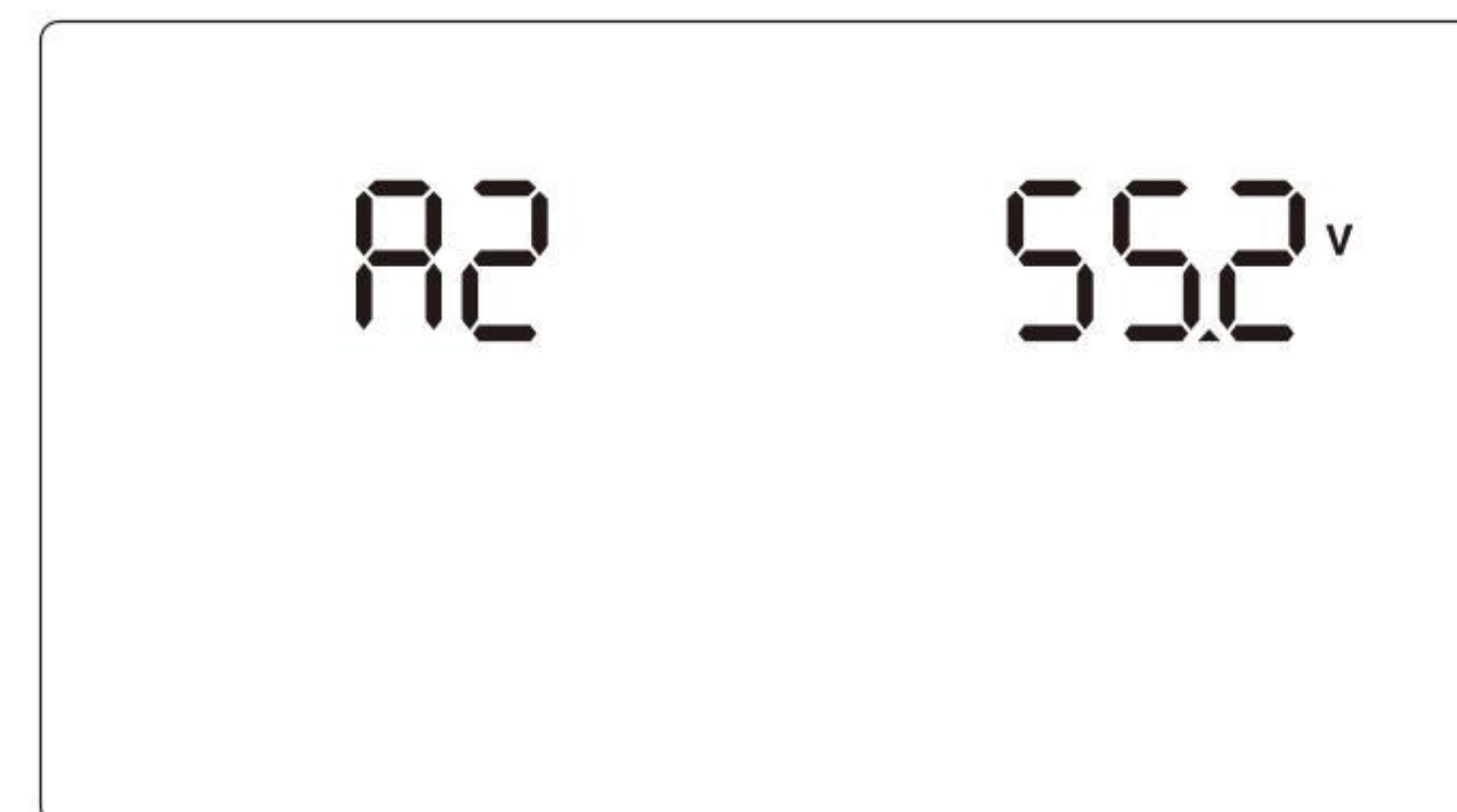

Function description: Float voltage setting. All the working modes can set, it takes effect immediately after setting is saved.

Noted:

48V Model: 48.0V~62.0V can be set, default is 55.2V;  
24V Model: 24.0V~31.0V can be set, default is 27.6V.

#### 4) Battery low voltage protection setting (A3)

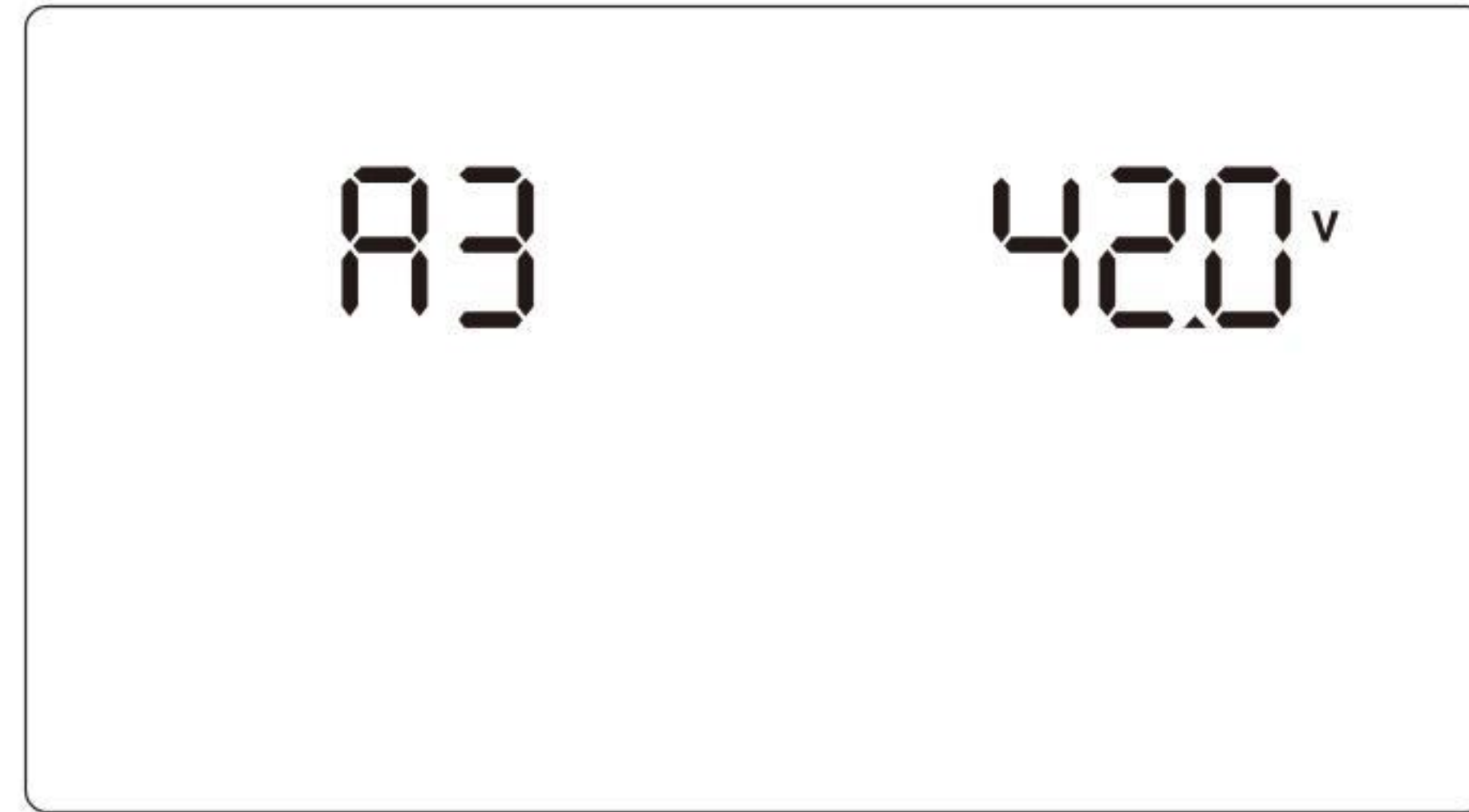

Function description: Battery low voltage protection setting. All working modes can be set, it takes effect immediately after setting is saved

Noted:

48V Model: 28.0V~52.0V can be set, Default: 42.0V;  
24V Model: 14.0V~26.0V can be set, default is 21V.

#### 5) Battery low voltage alarm setting (A4)

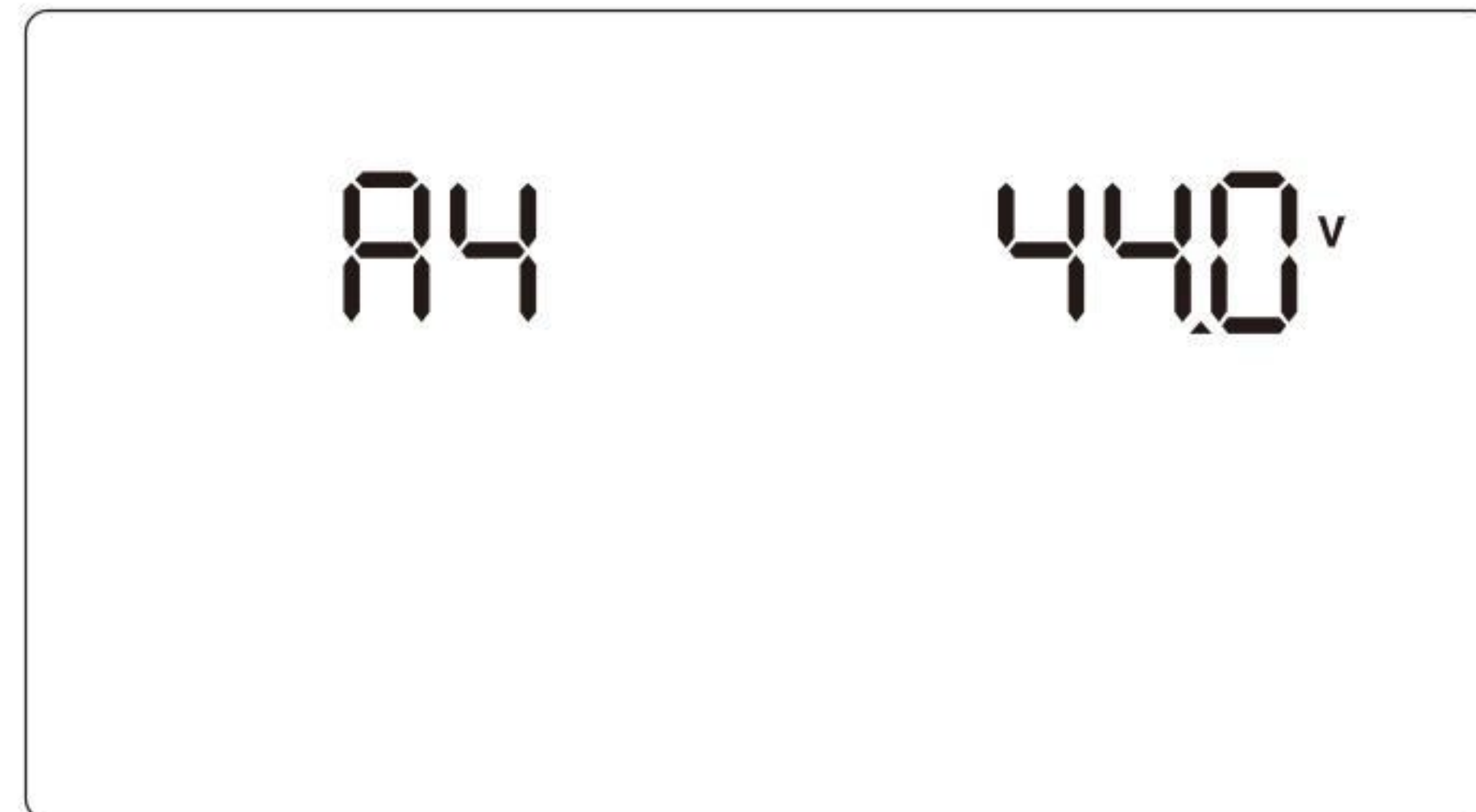

Function description: Battery low voltage alarm setting. All working modes can be set, it takes effect immediately after setting is saved.

Noted:

48V Model: 30.0V~54.0V can be set, default:44.0V;  
24V Model: 15.0V~27.0V can be set, default:22.0V

#### 6) Battery low voltage alarm setting (A5)

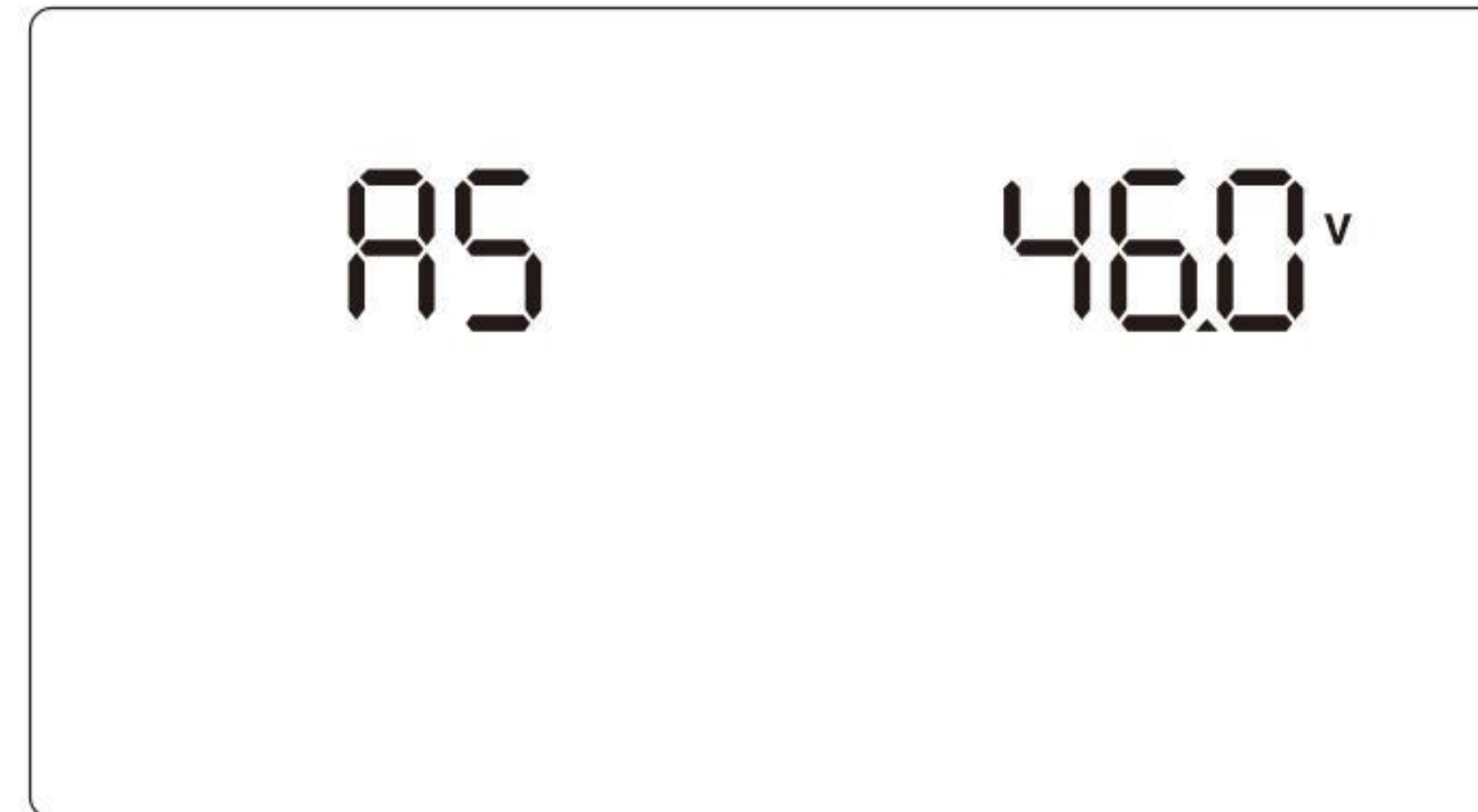

Function description: The recover battery voltage setting after low voltage protected. All working modes can be set, it takes effect immediately after setting is saved.

Noted:

48V Model: 30.0V~60.0V can be set, Default :52.8V;  
48V Model: 15.0V~30.0V can be set, Default :24V.

#### 7) Mains to battery mode voltage setting (A6)

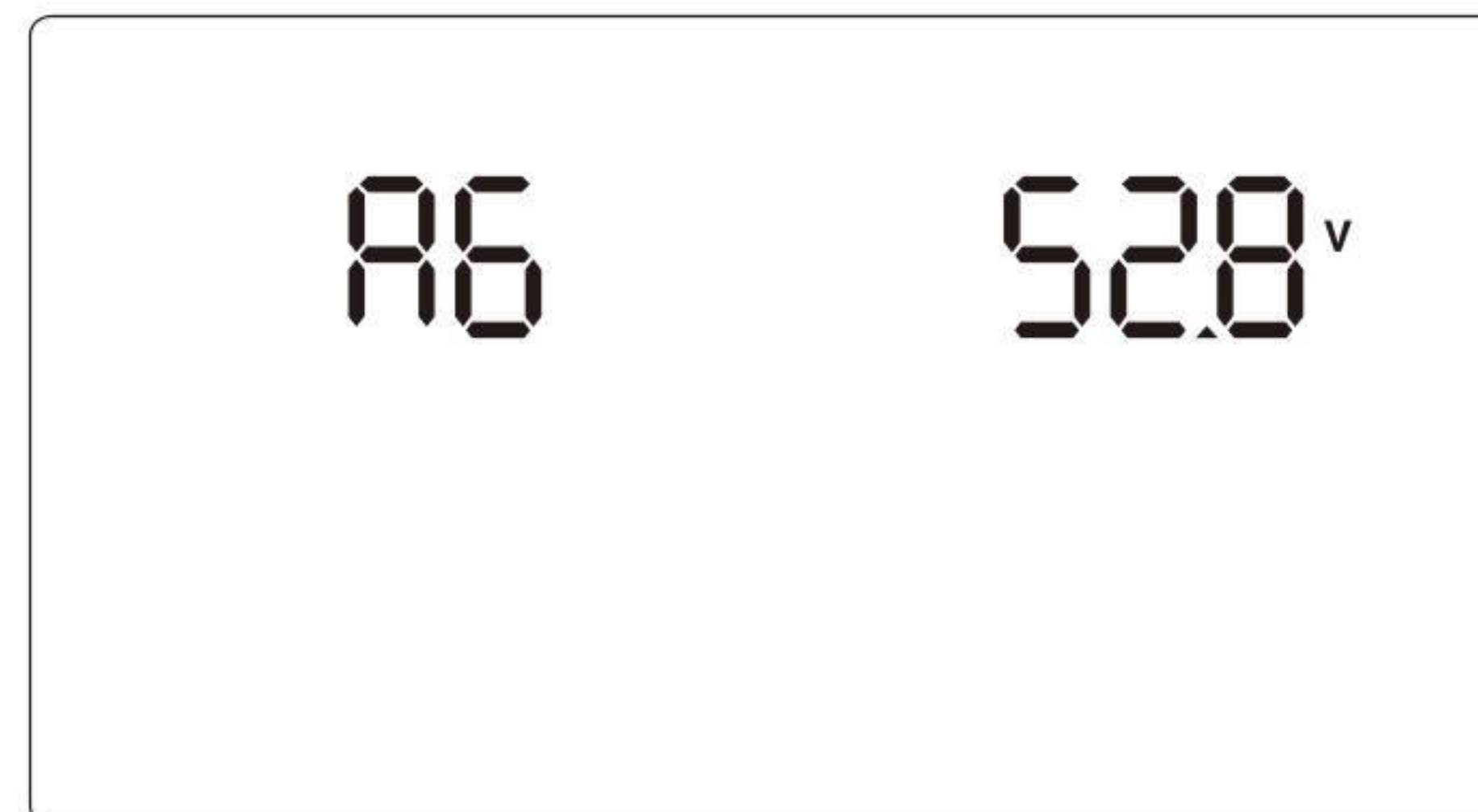

Function description: The inverter is set in battery priority (PBG) mode, and the battery voltage is set to restore the battery voltage from the mains to the battery supply. All working modes can be set, it takes effect immediately after setting is saved.

Noted:

48V Model: 36.0V~62.0V can be set, default 52.8V;  
24V Model: 18.0V~31.0V can be set, Default :26.4V.  
(This parameter is valid only when the battery type is lead-acid)

#### 8) Battery to mains voltage setting (A7)

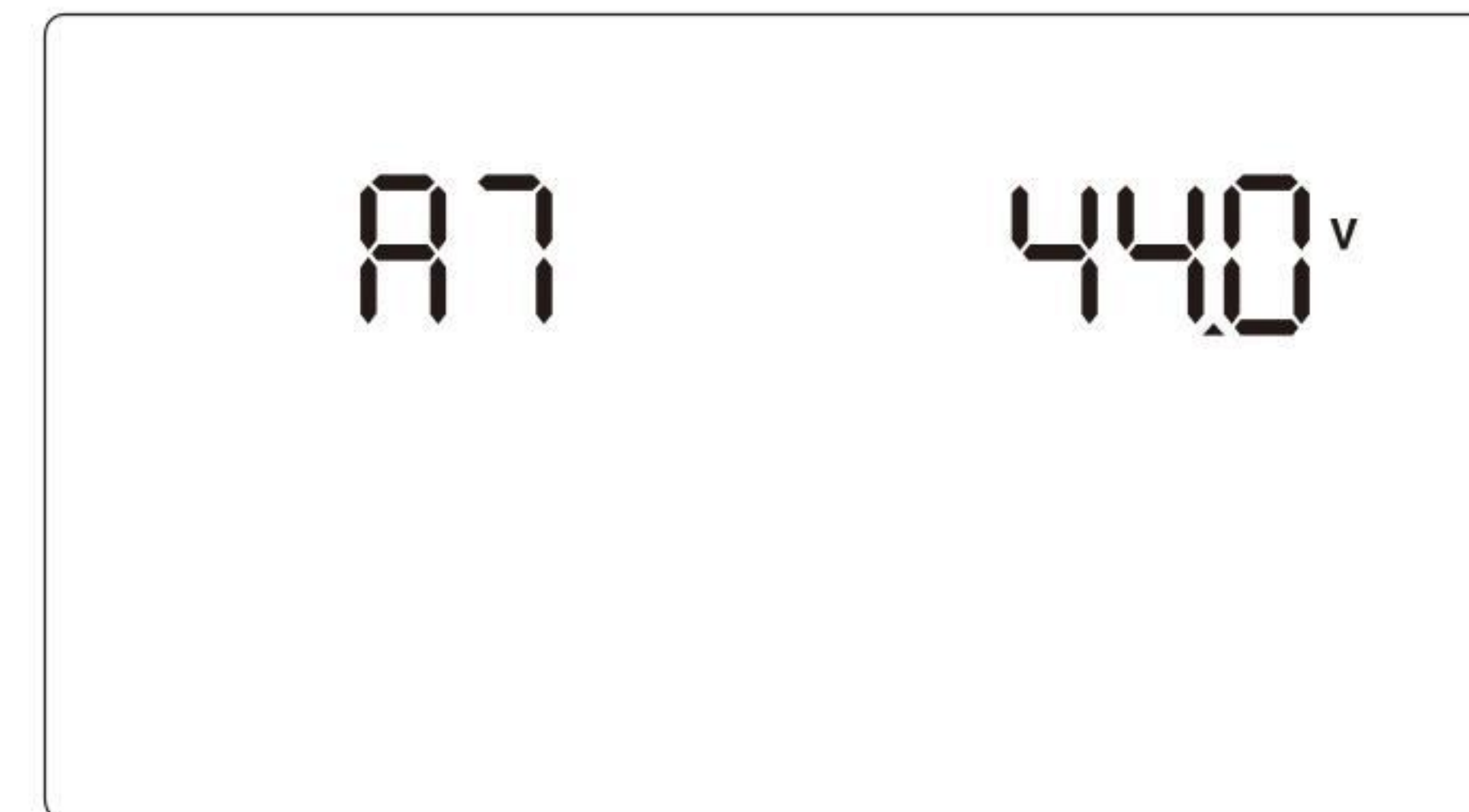

Function description: The inverter is set in battery priority (PBG) mode, Battery discharge low voltage setting from battery to mains. All working modes can be set, it takes effect immediately after setting is saved.

Noted:

48V Model: 28.0V~58.0V can set, default :44.0V;  
24V Model: 14.0V~29.0V can be set, Default :22.0V.  
(This parameter is valid only when the battery type is lead-acid)

#### 9) Frequency setting (A8)

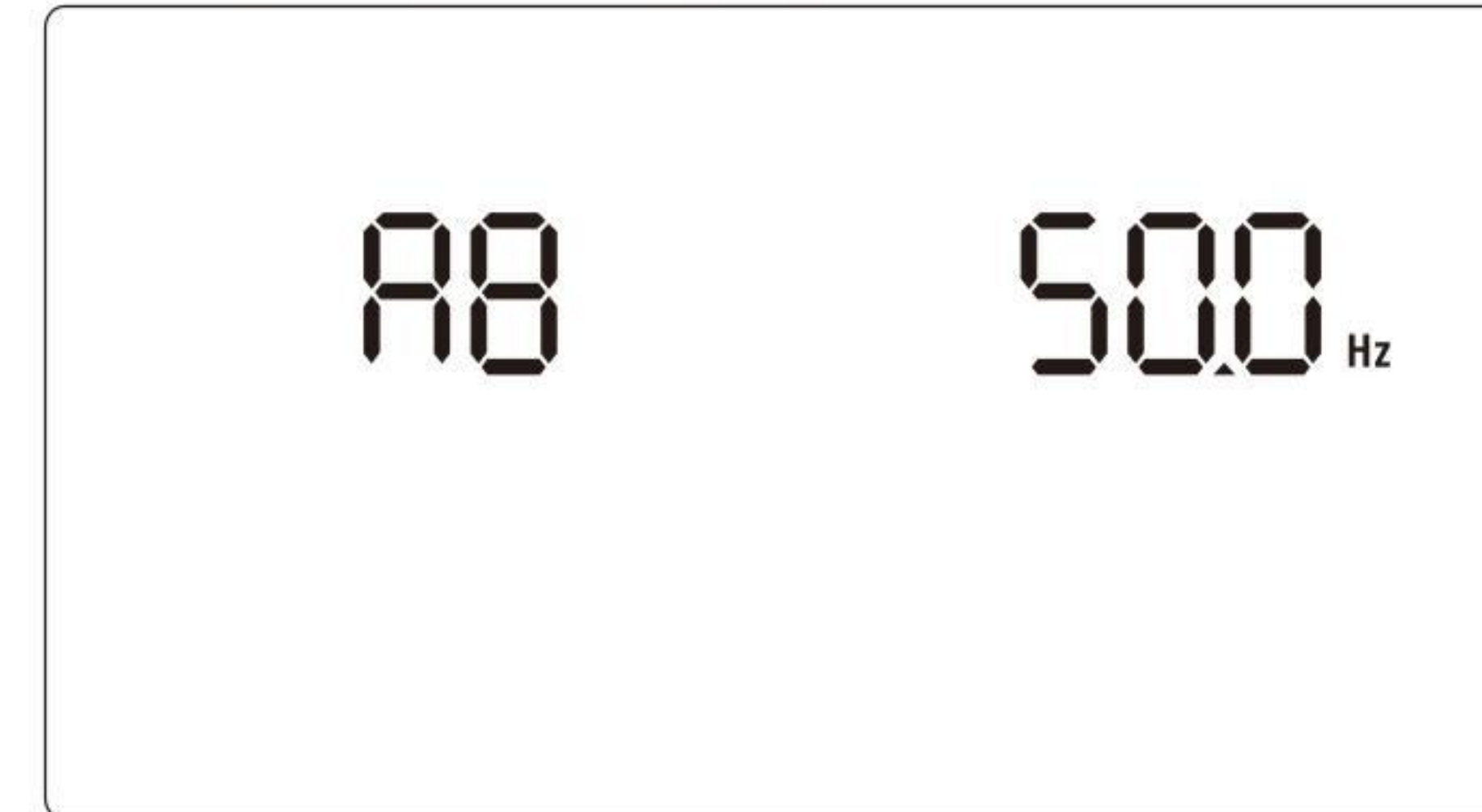

Function description: Frequency setting. All working modes can be set, it takes effect immediately after setting is saved.

Noted: 50Hz or 60Hz can be set, Default: 50Hz.

#### 10) Output voltage setting (A9)



Function description: Output voltage setting. All working modes can be set, it takes effect immediately after setting is saved.

Noted: 220V, 230V, 240V can be set, default :230V.

#### 11) Charging Priority Setting (A10)

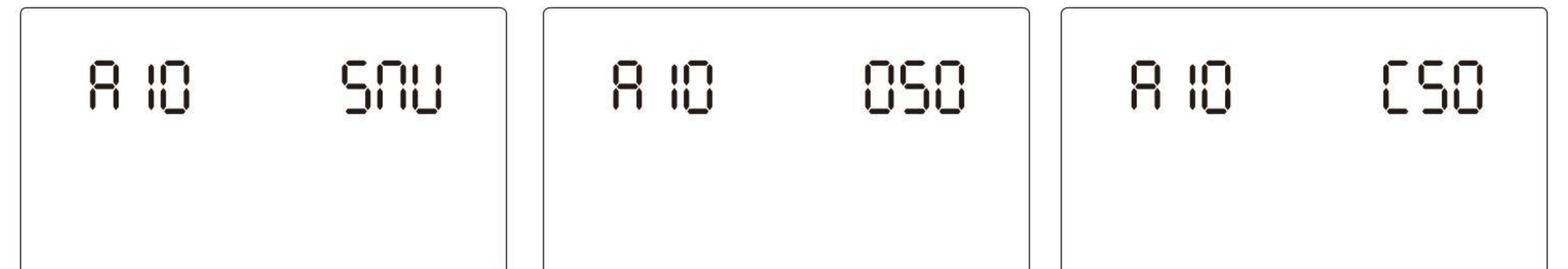

Function description: charging priority mode setting. Only setting under the battery mode, it takes effect immediately after setting is saved.

Noted: Three Option, default: SNU: PV & mains charging at the same time(PV power consume priority), OSO: Only PV charging, CSO: PV Charging priority (after without PV, Then Mains will charge the battery ).



### 12) Non battery mode settings (A11)

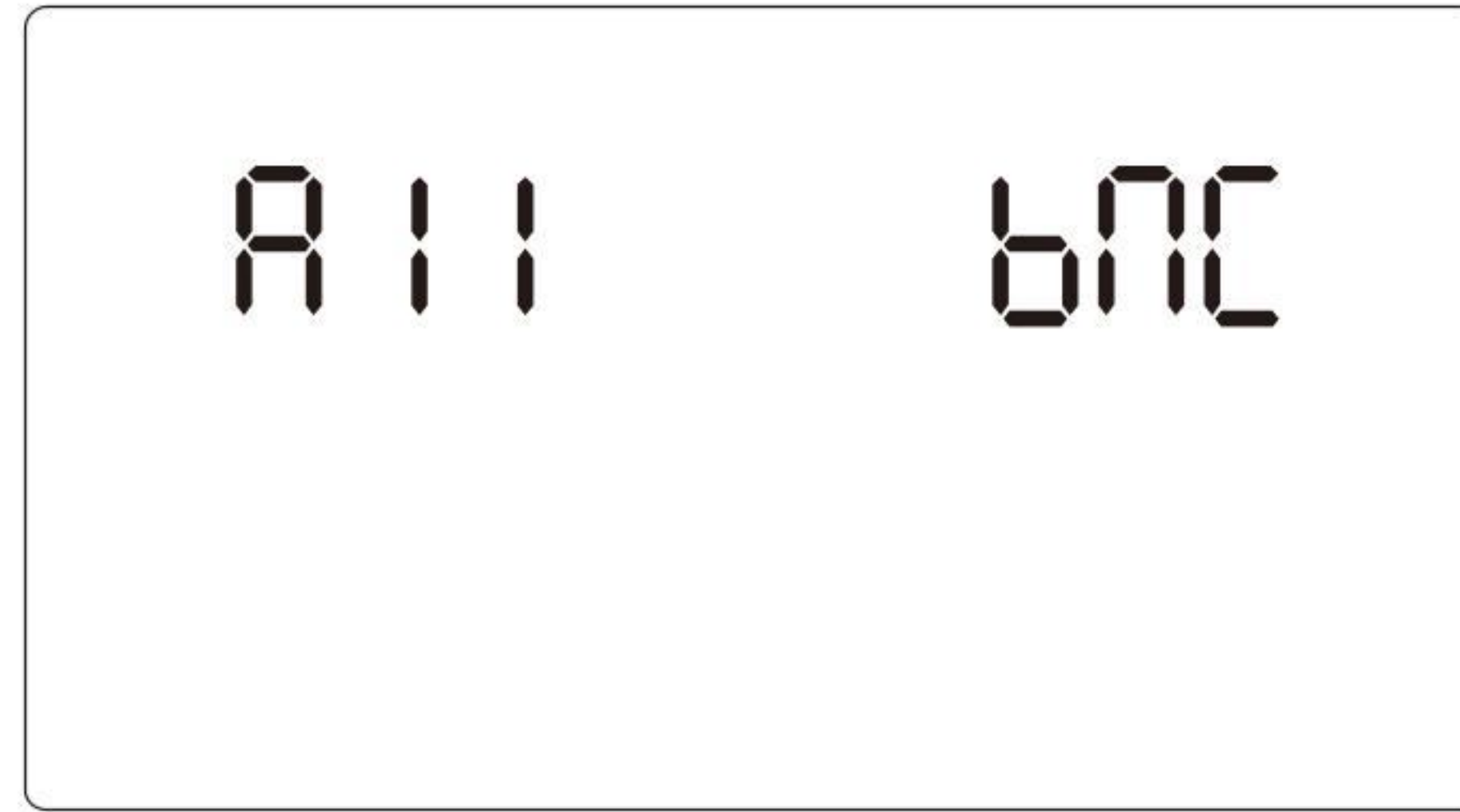
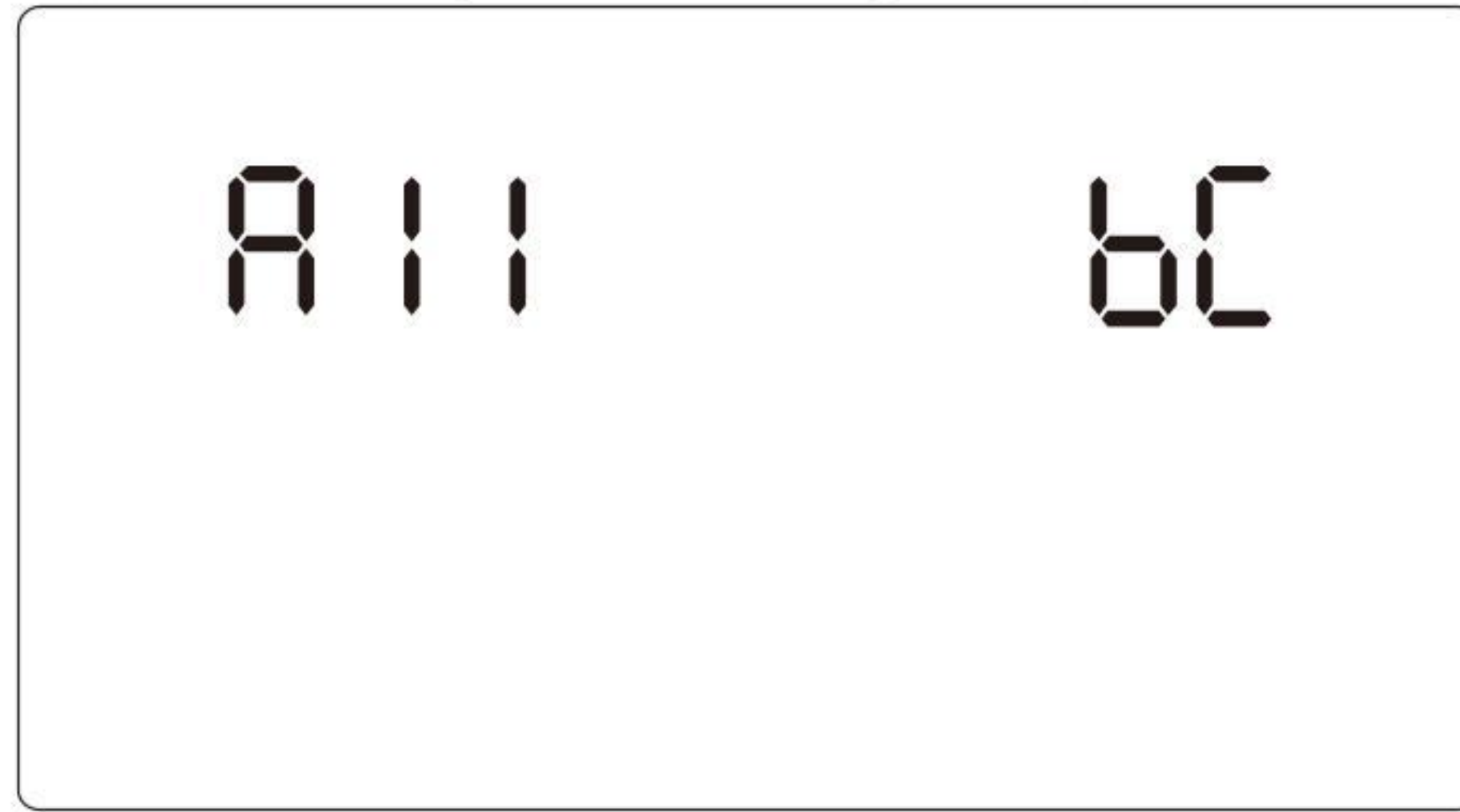

Function description: Set whether the inverter connected the battery or not. It can only be set in the battery mode, and the settings will take effect immediately after being saved.

Noted: The default is bC: connect battery, bNC: Disconnect battery

### 13) Mains charging current setting (A12)

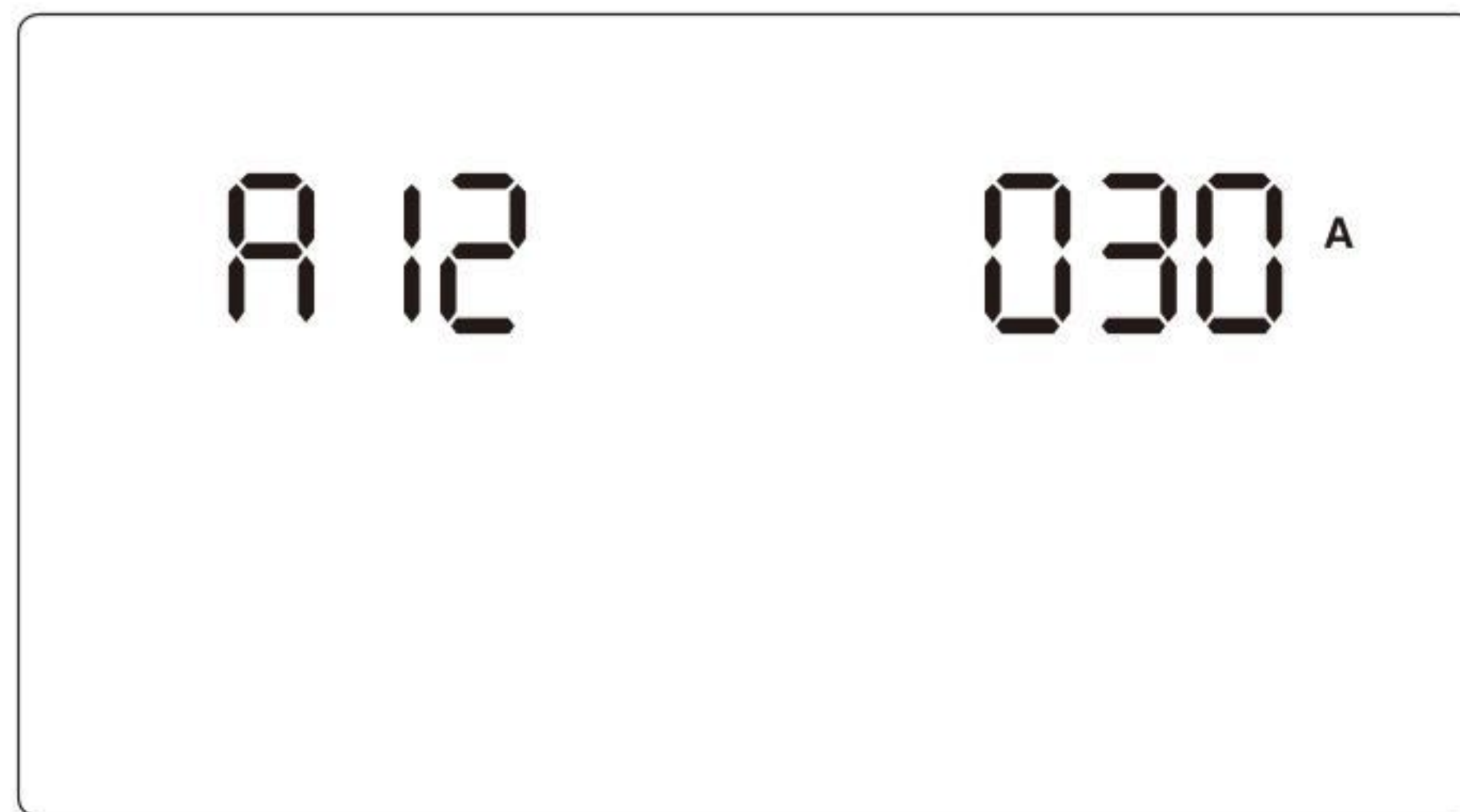

Function description: Mains charging current setting. All working modes can be set, and the settings will take effect immediately after being saved.

Noted: The default is 30A (Inverter setting range for different power segments 3.3KW: 1A~80A; 4.3KW: 1A~100A; 6.3KW: 1A~80A; 8.3KW: 1A~100A; 10.3KW: 1A~120A; 12.3KW: 1A~140A)

### 14) Maximum charging current setting (A13)



Function description: Maximum current setting for simultaneous charging of mains and photovoltaics. All working modes can be set, and the settings will take effect immediately after being saved

Noted: The default is 60A (Inverter setting range for different power segments 3.3KW: 1A~120A; 4.3KW: 1A~150A; 6.3KW: 1A~120A; 8.3KW: 1A~150A; 10.3KW: 1A~180A; 12.3KW: 1A~200A)

### 15) Mains input voltage range setting (A14)

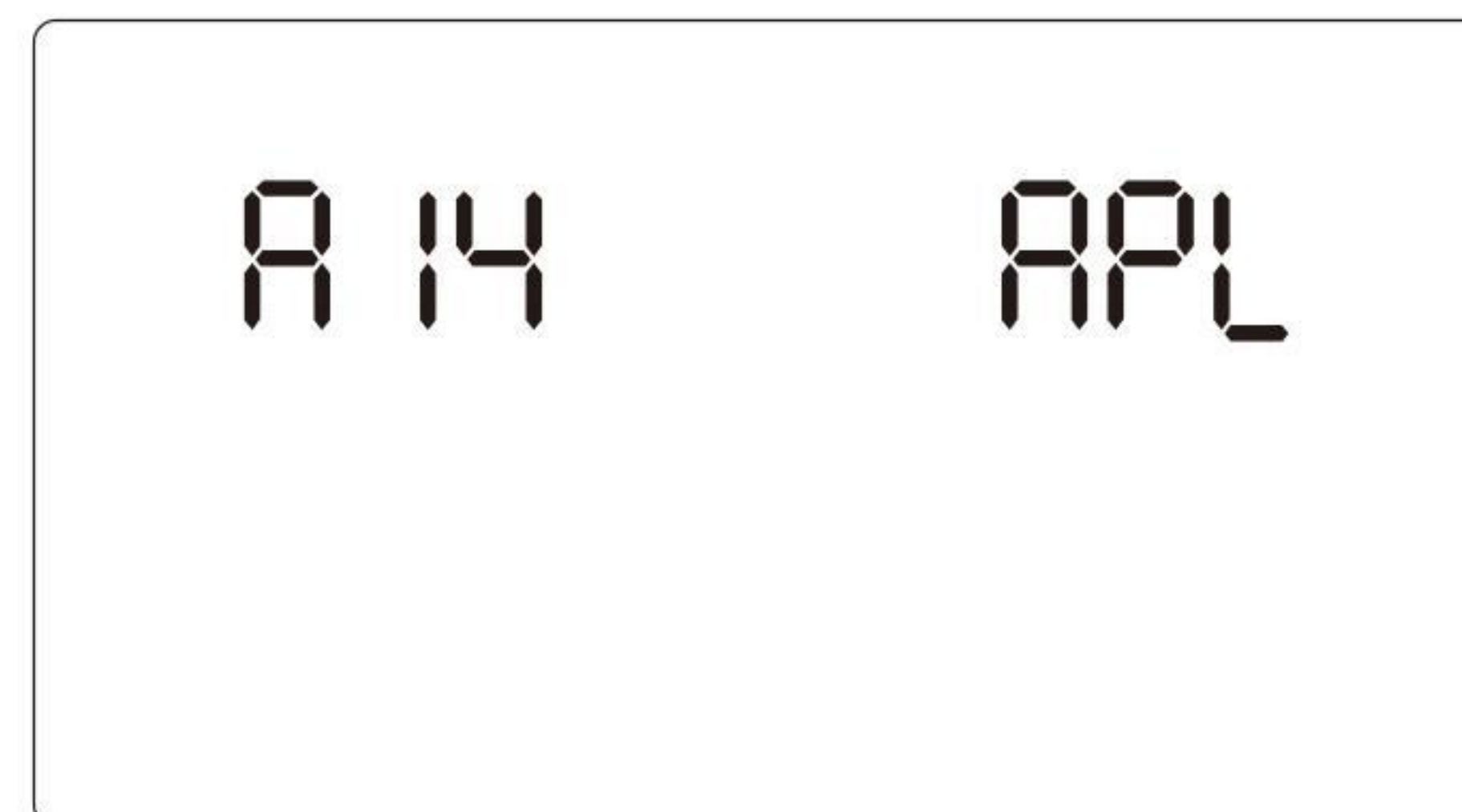
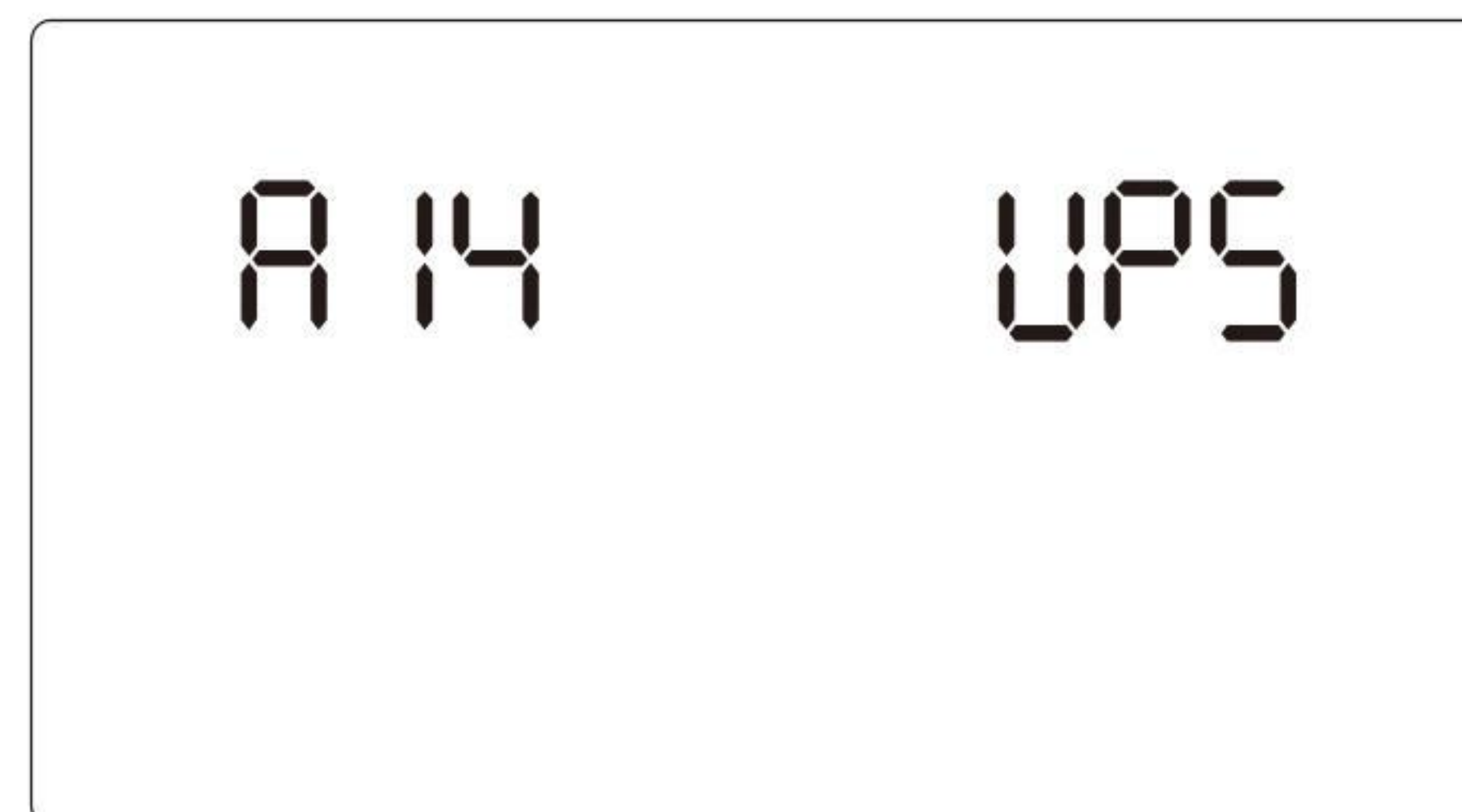

Function description: Mains input voltage range setting. All working modes can be set, and the settings will take effect immediately after being saved.

Note: The default is UPS: the mains input voltage range is 165V~280V, APL: the mains input voltage range is 120V~280V.

### 16) Working mode setting (A15)

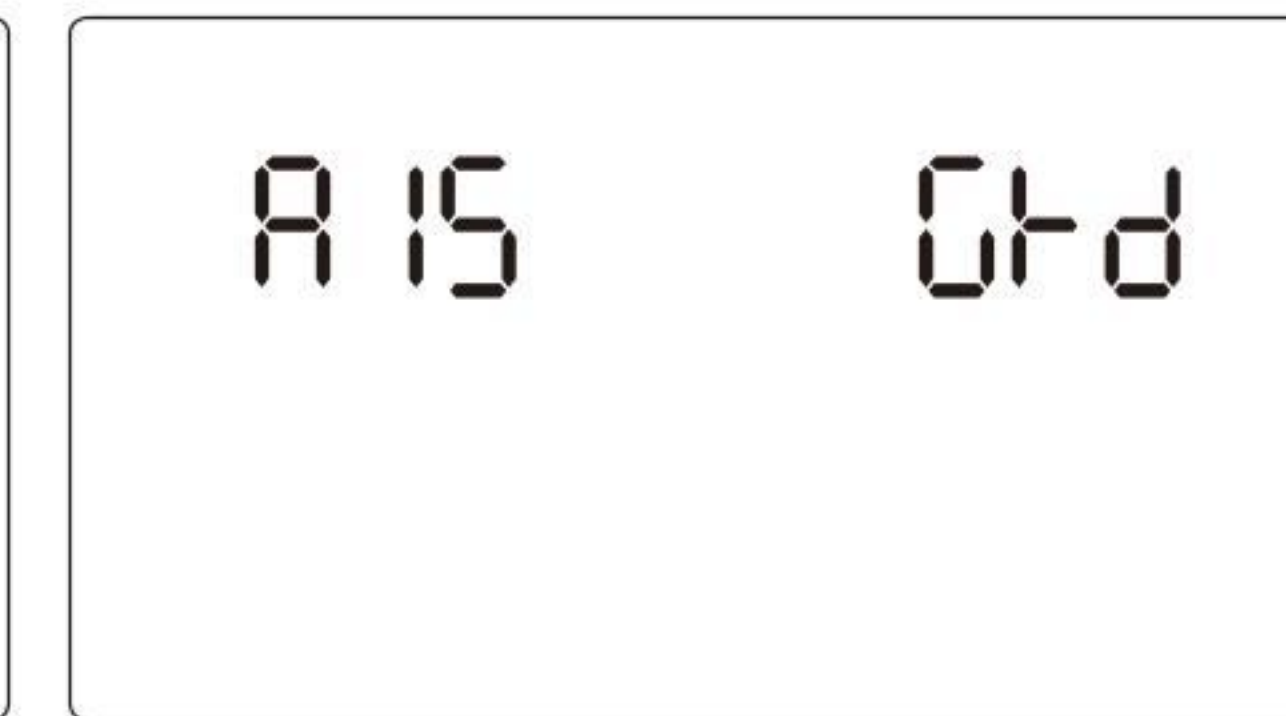
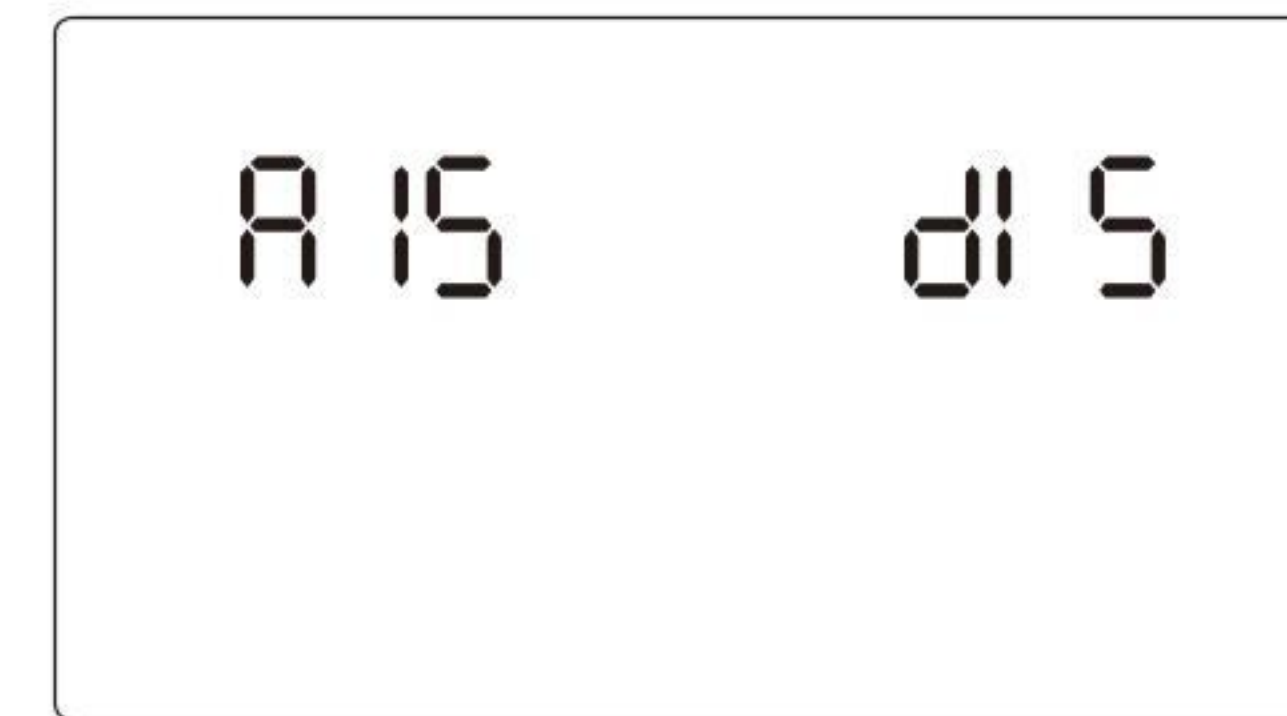

Function description: Working mode setting. It can only be set in the battery mode, and the settings will take effect immediately after being saved.

Note: There are three options. The default is GRD: hybrid mode, GRE: grid-connected feed mode, DIS: off-grid mode.

### 17) Grid-connected current setting (A16)

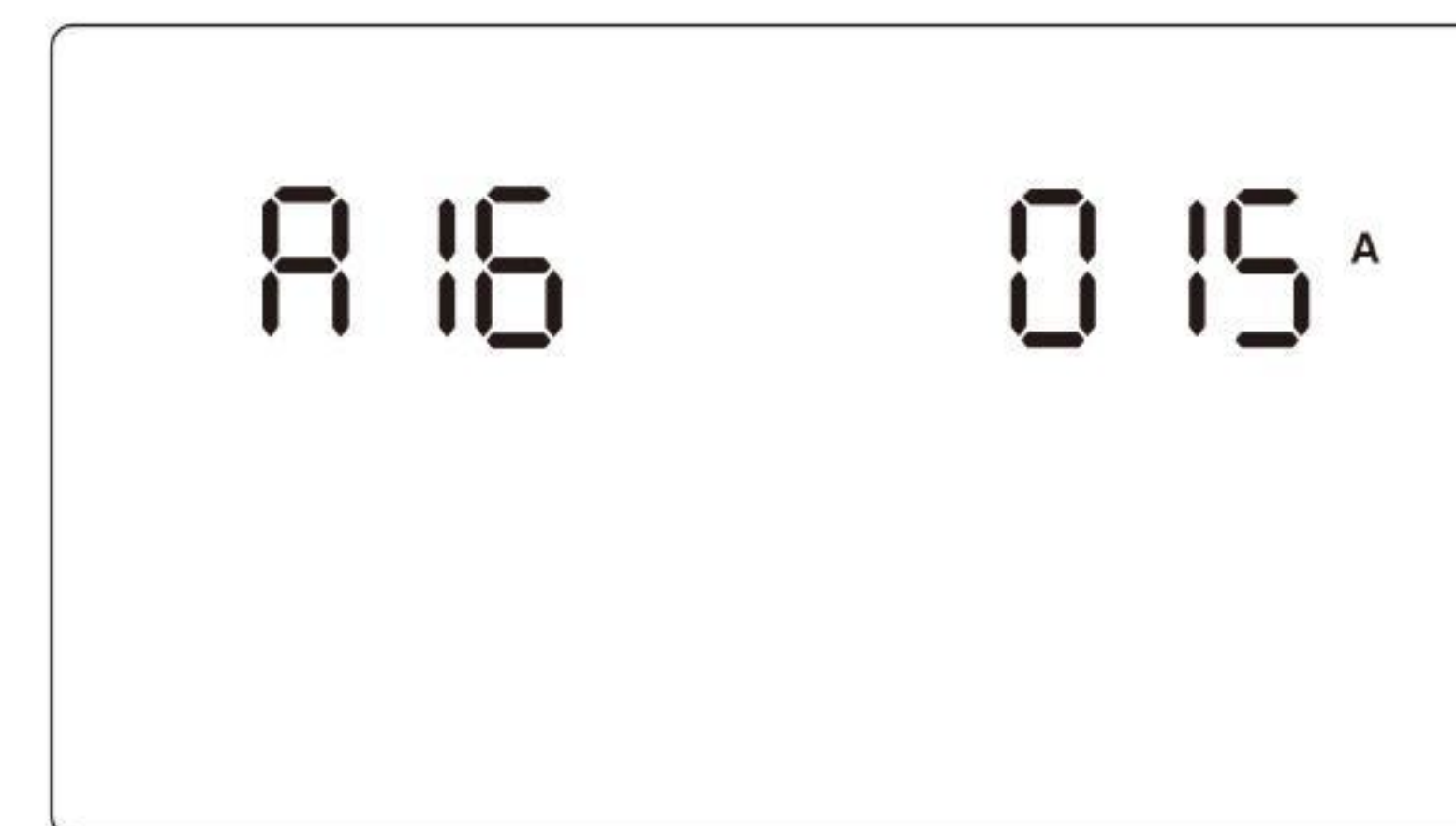

Function description: Set the current at AC INPUT when the grid is connected.

Note: The default value is 0A. The range of grid-connected current of inverters in different power segments is different, the minimum is 0A, and users can adjust it according to their needs.

### 18) Lithium battery BMS communication protocol setting (A17)

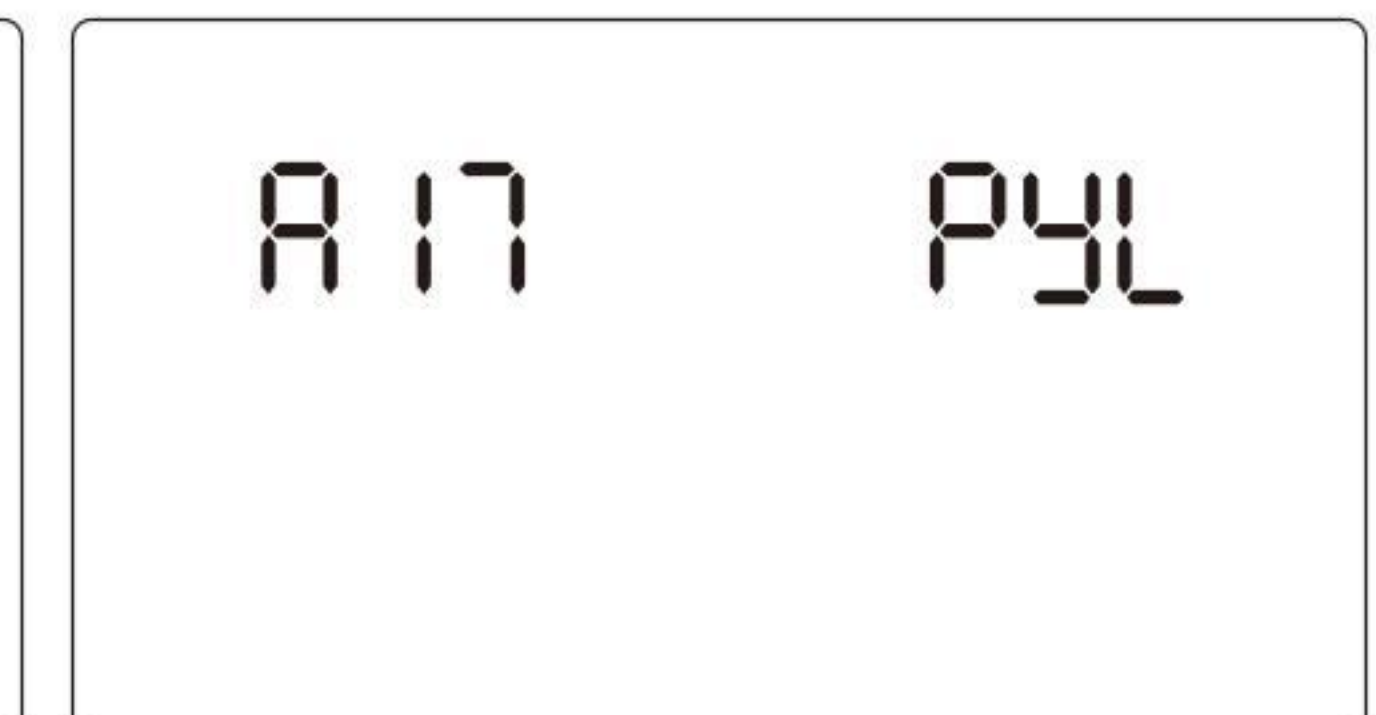
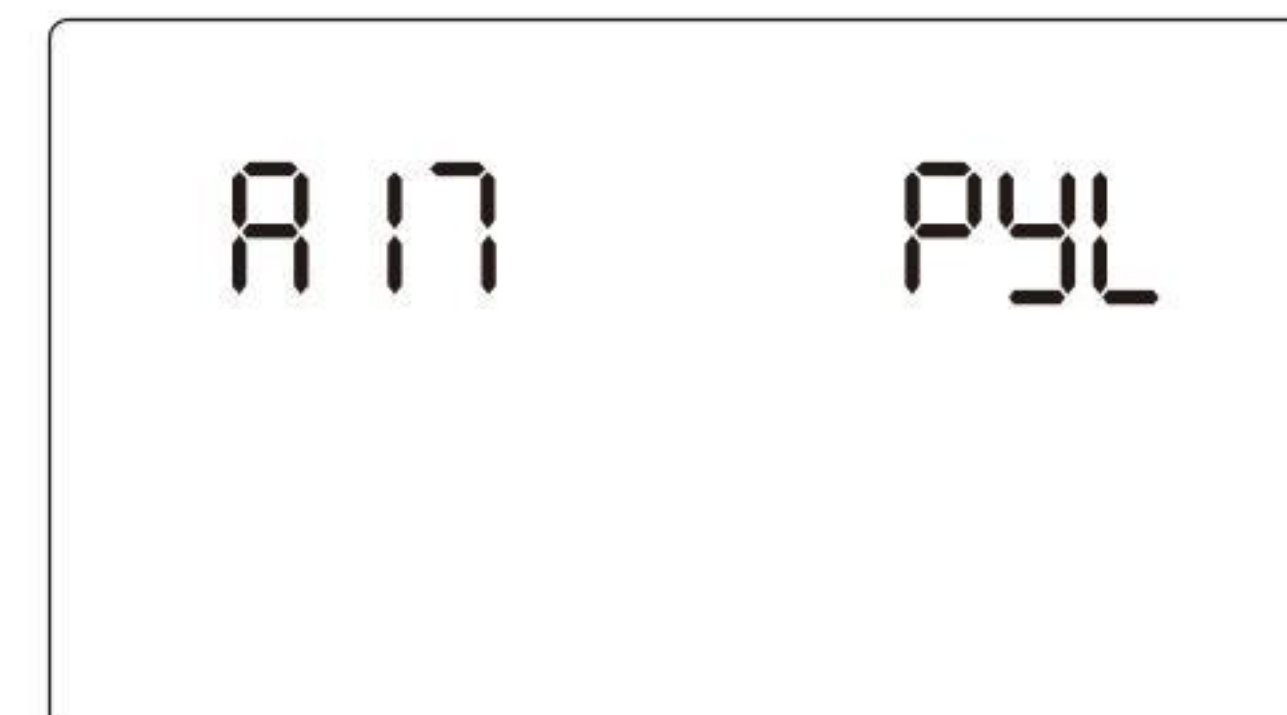

Function description: Communication protocol settings for communication with lithium batteries. All working mode can be set, and the settings will take effect immediately after being saved.

Note: There are 6 protocol options. The default is Pb: lead-acid battery, GRD: Growatt communication protocol, VLO: Voltronic communication protocol, PYL: Pylon communication protocol (there are two Pylon lithium battery communication protocols, logo Both are PYL), PAC: PACE Communication Protocol.

**19) BMS Communication address setting (A18)**



Function description: Set the BMS communication address code. All working modes can be set, and the settings will take effect immediately after being saved.  
Note: 000~247 can be set, the default is 000.

**20) Switch off SOC Setting (A19)**



Function description: Set the inverter switch off SOC. In the battery mode, the lithium battery SOC reaches the set value and shuts down (take effect under the communicate with the lithium battery). All working modes can be set, and the settings will take effect immediately after being saved.  
Note: 1%~80% can be set, the default is 5%.

**21) Low voltage recover SOC setting (A20)**



Function description: low-voltage recover SOC setting. After low-voltage protection, the inverter recover when the battery voltage reaches the set value (it needs to communicate with the lithium battery to take effect). All working modes can be set, and the settings will take effect immediately after being saved.  
Note: 1%~90% can be set, the default is 80%

**22) Inverter to mains battery SOC setting (A21)**



Function description: Set the SOC value of the battery mode-to-mains . When the inverter is set in battery priority (PBG) mode and the mains is normal, the battery SOC is discharged to the set value and switches from battery supply to mains supply. status (it takes effect after communicating with the lithium battery). All working modes can be set, and the settings will take effect immediately after being saved.  
Note: 1%~80% can be set, the default is 10%.

**23) Mains to battery mode SOC setting (A22)**



Function description: Set the SOC value from mains to battery. The inverter is set in the battery priority (PBG) mode. After the battery SOC recovers to the set value, it switches from the mains power supply state to the inverter power supply state (effect after lithium battery communication). All working modes can be set, and the settings will take effect immediately after being saved.  
Note: 1%~100% can be set, the default is 90%.

**24) Charging cut off SOC (A23)**



Function description: Set the inverter charging cut-off SOC. When the lithium battery SOC reaches the set value under the mains power supply, it will stop charging (it needs to communicate with the lithium battery to take effect). All working modes can be set, and the settings will take effect immediately after being saved.  
Note: 1%~100% can be set, the default is 100%.

**25) Charging cut off SOC (A24)**



Function description: After battery low voltage protection, the battery is charged to the recovery setting value. Whether to automatically turn on the inverter output setting item. It can only be set in the battery mode, and the settings will take effect immediately after being saved.  
Note: The default is BRE: Recover, BRD: Do not recover

**26) Over load recover setting (A25)**

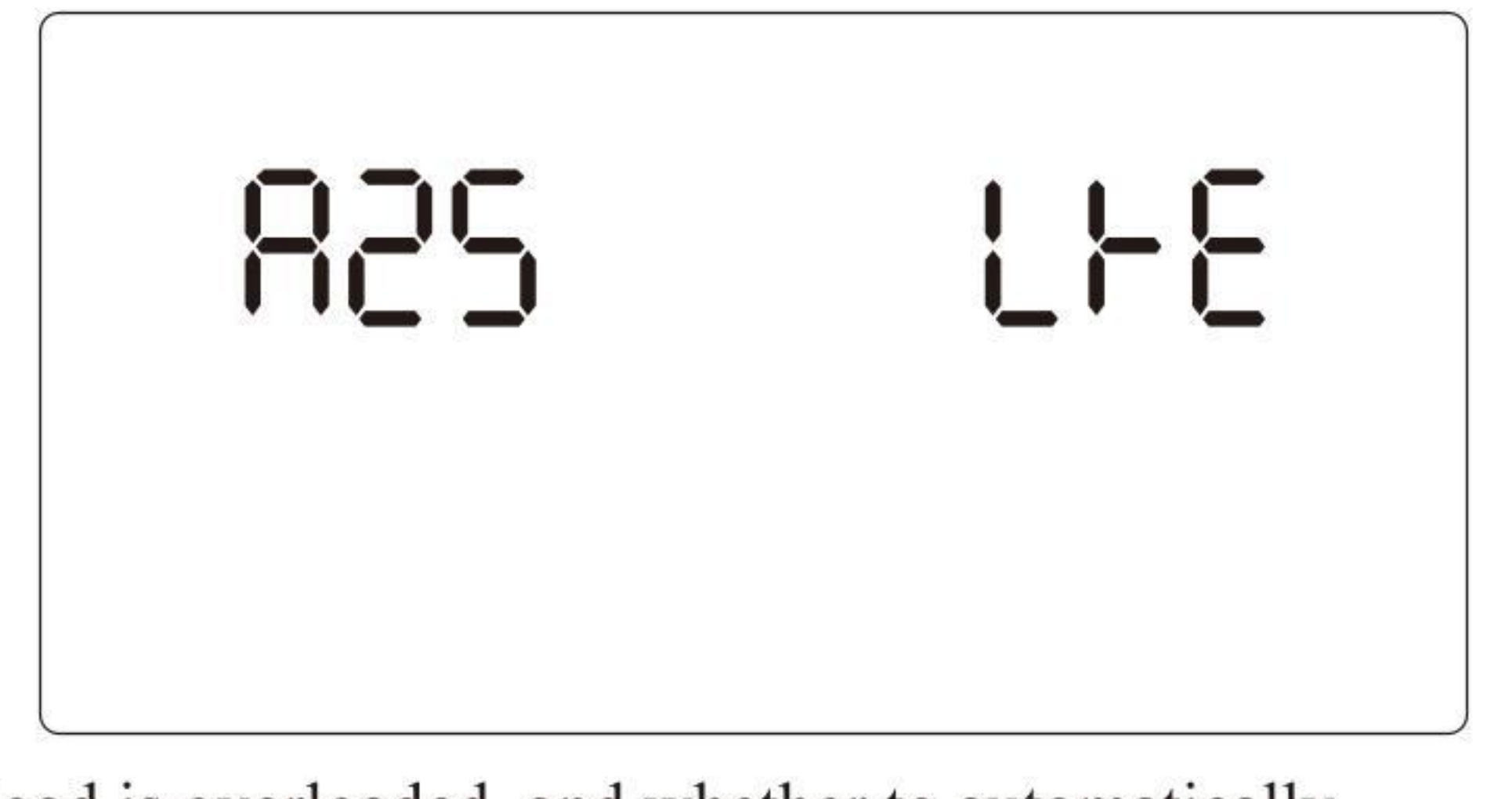

Function description: Whether to recover or not when the load is overloaded, and whether to automatically restore the power-on function after the inverter is overloaded. It can only be set in the battery mode, and the settings will take effect immediately after being saved.  
Note: The default is LRD: Do not recover, LRE: Recover.

### 27) Recover after over temperature (A26)

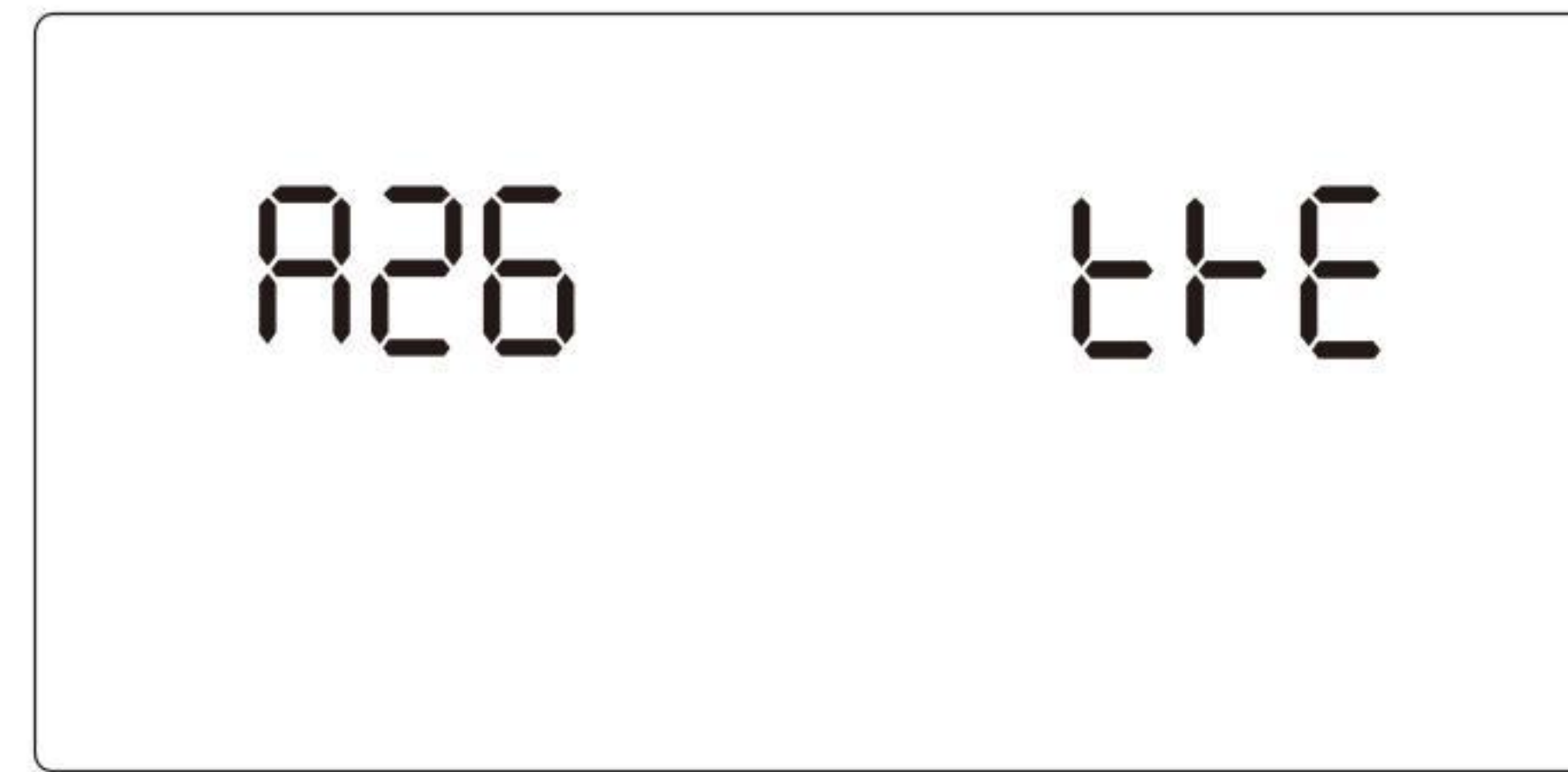

Function description: Whether to recover the setting item when the temperature is too high. After the inverter is over-temperature protected, whether to automatically restore the power-on function when the temperature drops. It can only be set in the inverter state, and the settings will take effect immediately after being saved.

Note: The default is TRD: Do not recover ; TRE: Recover.

### 28) Inverter computer communication address setting (A27)



Function description: Set the computer communication address code. All working modes can be set, and the settings will take effect immediately after being saved.  
Noted: 000~247 can be set, default is 001

### 29) Equipment neutral grounding settings (A28)(This setting is invalid for 3.3KW/4.3KW/6.3KW models)

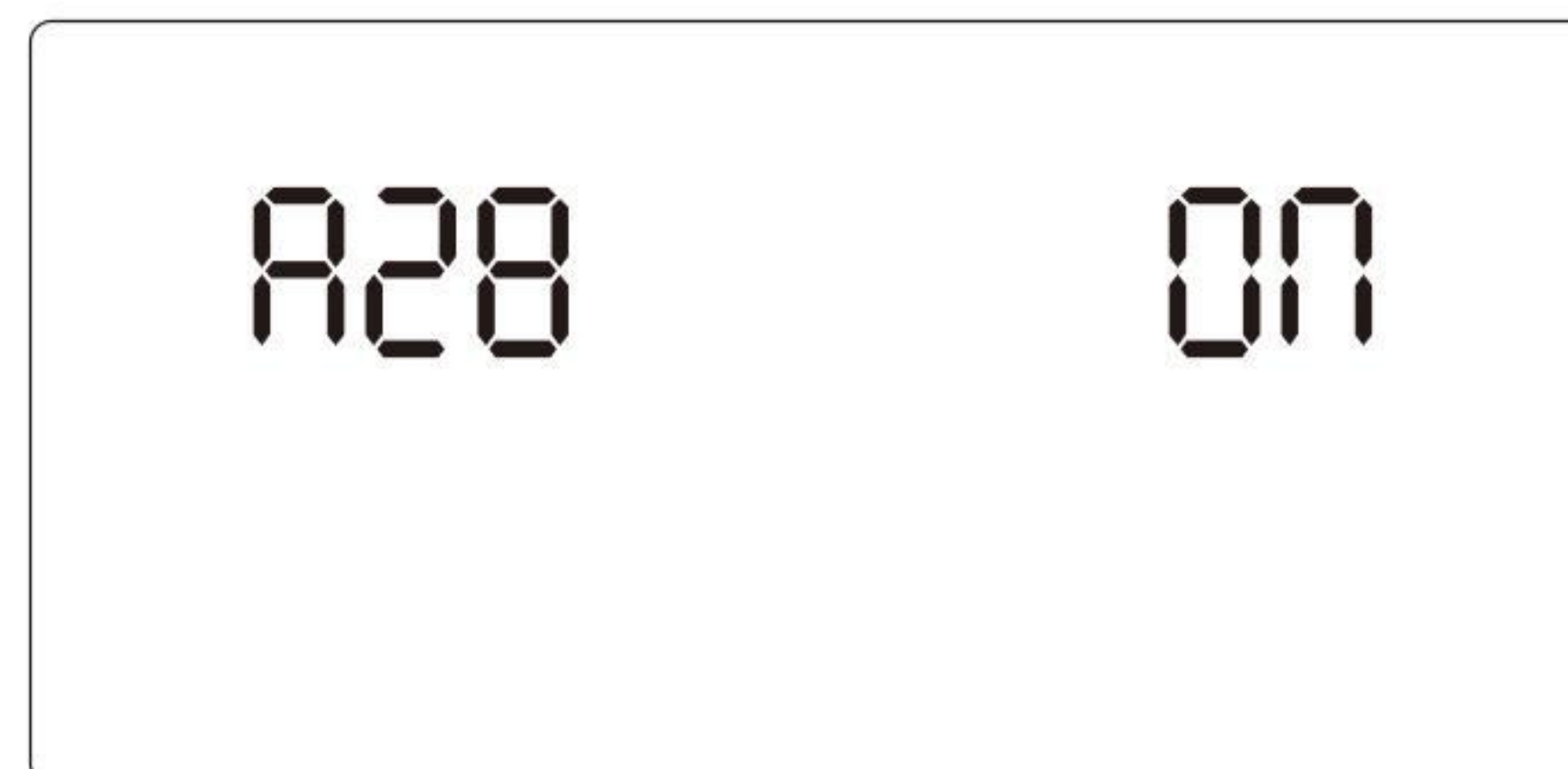

Function description: Set whether the output neutral line is grounded in the battery mode. It can only be set in the battery mode, and the settings are saved effective immediately.

Note: Default OFF: off (neutral line is not grounded), ON: open (neutral line is grounded).

### 30) Equipment power generation reset (A29)

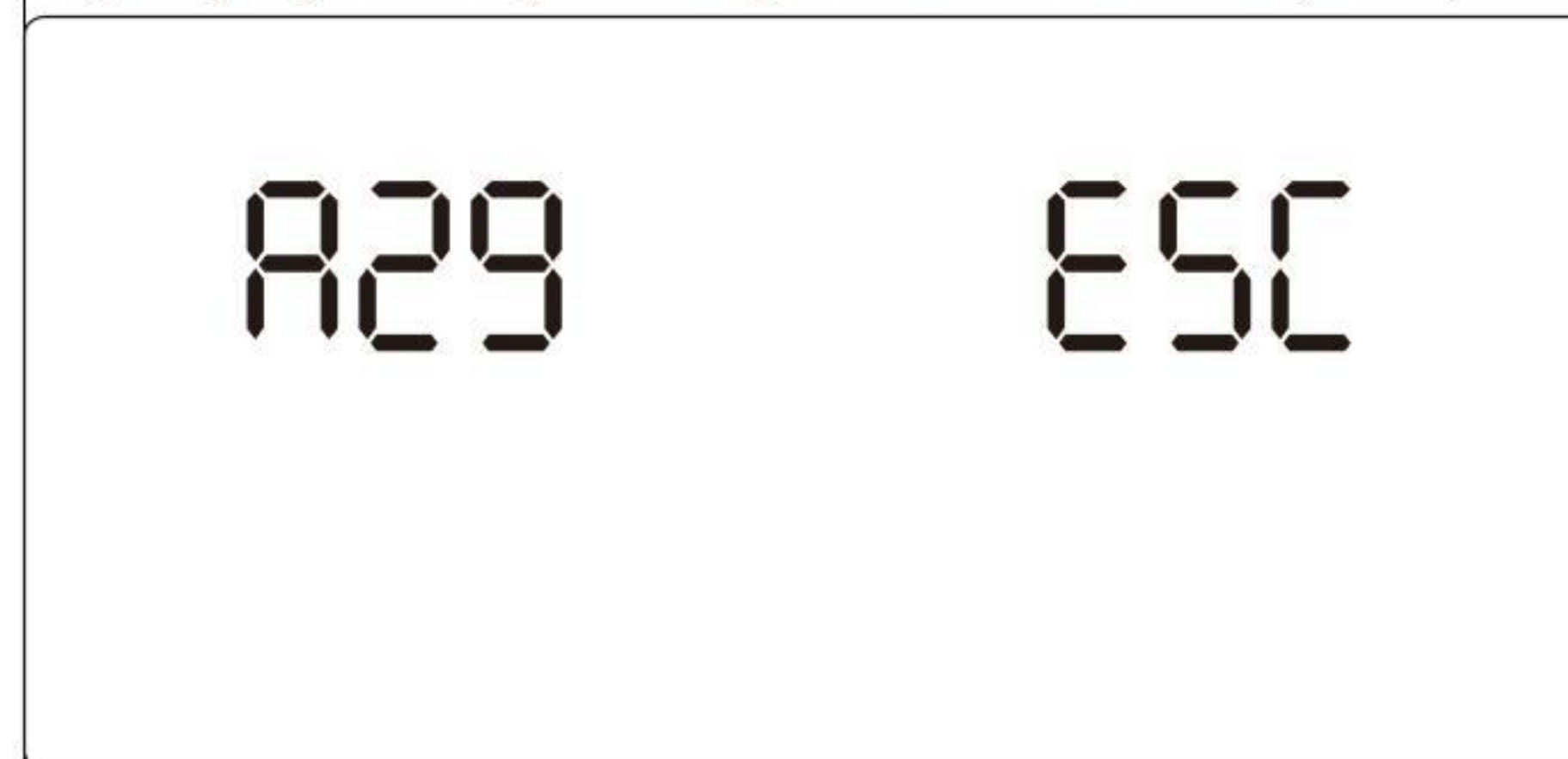

Function description: Inverter power generation reset item. It can only be set in the battery mode, and the settings will take effect immediately after being saved.

Note: The default is ESC: the power generation is not cleared, CLR: the power generation is cleared.

**Note: The above default values are for reference only and are subject to change without prior notice.**

## 5. Fault description

When the inverter has fault alarm, the LED red light flashes; when there is fault protection, the LED red light is on, and the LCD displays the fault code. For specific fault code description and solution, refer to the following sheet:

### Fault code sheet

Fault code	Fault message	Rx
30	EEPROM Read and write fault	Please contact the supplier
31	Communication failure with the main controller	Please contact the supplier
32	Abnormal parameter setting	Please contact the supplier
33	Abnormal reference voltage	Please contact the supplier
34	BUS soft start fault	Please contact the supplier
35	Hardware over flow	Please check whether the output is overloaded or has an excessively large non-linear load.
36	Short circuit fault	Please check the output for a short circuit to exclude the abnormal load
37	Inverter fault	Please contact the supplier
38	Battery over voltage alarm	Please check whether the battery voltage is too high, whether the number of battery cells is correct, and whether the voltage of each battery cell is normal.
39	Battery over voltage protection	Please check whether the battery voltage is too high, whether the number of battery cells is correct, and whether the voltage of each battery cell is normal.
40	Battery low voltage protection	Please check whether the battery voltage is too low, whether the number of battery cells is correct, and whether the voltage of each battery cell is normal.
41	Battery low voltage alarm	Please check whether the battery voltage is too low, whether the number of battery cells is correct, and whether the voltage of each battery cell is normal.
42	BUS high voltage fault	Please contact the supplier
43	BUS low voltage fault	Please contact the supplier
44	Overload alarm	Please check whether the output load is overloaded and reduce the load appropriately
45	High temperature of the inverter radiator	Please check whether the cooling fan is normal, whether the ambient temperature is too high, and whether the inverter vent is blocked.
46	DC / DC, the radiator at high temperature	Please check whether the cooling fan is normal, whether the ambient temperature is too high, and whether the inverter vent is blocked
47	MPPT radiator with high temperature	Please check whether the cooling fan is normal, whether the ambient temperature is too high, and whether the inverter vent is blocked
48	PV1 high voltage	Please check whether the PV input voltage of PV1 exceeds the operating range.
49	PV2 high voltage	Please check whether the PV input voltage of PV2 exceeds the working range
50	Mains high voltage	Please check whether the input mains voltage is too high

51	Abnormal frequency	Please check whether the mains frequency is normal
52	Remote shutdown	Please determine if a remote shutdown command was sent
53	Abnormal communication with the lithium battery	Please check whether the inverter and the lithium battery communication protocol correspond, and whether the connection line is correct
54	Lithium battery single cell or total voltage is too high	Please check whether the single-section cell voltage and total voltage of the lithium battery are too high
55	Lithium battery single cell or total voltage is too low	Please check whether the single-section cell voltage and total voltage of the lithium battery are too low
56	Lithium battery discharge overcurrent	Please check whether the load power is too large
57	Lithium battery charge overcurrent	Please appropriately reduce the maximum charging current set by the inverter
58	Lithium battery temperature is abnormal	Please contact the supplier

## 6. Introduction to output priority and working mode

### A.Grid-Tie mode

#### 1. Mains power priority

Mains power and PV provide power to the load at the same time, and the battery only provides power to the load when the mains power is unavailable;

PV are given priority to charge the battery, and when there is excess energy, it will be used to power the load and finally feed the grid.

##### 1.1 When there is PV and mains power

- Mains power gives priority to providing load energy; photovoltaics charge the battery.
- The battery is fully charged, and the remaining PV energy supplies power to the load. If the PV power generation is less than the load power, the mains power supplies supplementary power.
- The remaining PV power generation is greater than the load power and feeds power to the grid.
- When the PV power generation is insufficient (not enough for the set charging power), the mains will charge the battery to make up the remaining charging current. With PV, no mains power

##### 1.2 There have PV power , no mains power

- PV give priority to providing load energy, and the remaining energy is used to charge the battery.
- PV give priority to providing load energy.

If the PV power energy is insufficient, the battery discharges to supplement the load power supply.

- PV give priority to providing load energy.

If the PV power energy is insufficient, the battery discharges to supplement the load power supply. (The battery is discharged to low-voltage protection, the inverter switches to standby state, the PV power charges the battery, and the battery is charged until the battery returns to the set value, and the inverter output can be resumed.

Or manually press the power button twice with an interval of 1 to 2 seconds. Reinvertable output)

##### 1.3 There have mains power, no PV

- The mains power supplies power to the load and charges the battery according to the charging setting value.
- If the mains power is lost, the battery will be discharged.

When the battery is discharged to low voltage, it will be switched to standby.

#### 2. PV power priority

Mains power and PV power provide power to the load at the same time, and the battery only provides power to the load when the mains power is unavailable; PV power is given priority to power the load, and when there is excess energy, it will be used to charge the battery. Finally, it feeds power to the grid.

##### 2.1 There is PV and mains electricity

- PV power energy is provided to the load first, and the excess energy is used to charge the battery.
- When the battery voltage is not very low, and the battery voltage reaches the grid connection condition (it does not need to be fully charged, the battery voltage depends on the mains voltage, if the mains voltage is 230V, the battery voltage is above 46V), the remaining PV energy feeds into the grid.
- The PV power energy is insufficient for load use, the charging current is reduced to 0, and the mains power supplies the insufficient energy. (That is, photovoltaic + mains power are loaded at the same time)

##### 2.2 With PV, no mains power

- PV solar energy is provided to the load first, and the excess energy is used to charge the battery.
- If the PV power energy is insufficient for the load, the battery will be discharged to supplement it.
- PV power give priority to providing load energy.

If the PV power energy is insufficient, the battery discharges to supplement the load power supply. (The battery is discharged to low voltage protection, the inverter switches to standby state, the photovoltaic charges the battery, the battery is charged to the battery low voltage recovery setting value, and the inverter output can be resumed. Or manually press the power button twice, with an interval of 1 to 2 seconds. , can be re-inverter output).

##### 2.3 With mains power and no PV

- The mains power supplies power to the load and charges the battery according to the charging setting value.
- If the mains power is lost, the battery will be discharged. When the battery is discharged to low voltage, it will be switched to standby.

#### 3. Battery priority (off-grid operation mode)

PV power will give priority to supplying power to the load. If the PV power are insufficient or unavailable, batteries will be used as a supplement to provide power to the load. When the battery discharge voltage reaches the set value, it will switch to the mains to supply power to the load.

##### 3.1 There is PV and mains electricity

- The inverter works in the inverter state, PV power energy gives priority to powering the load, and excess energy charges the battery.
- When the PV power energy is insufficient for the load, the battery is discharged to supplement, and the PV and battery supply power to the load at the same time.
- The battery is discharged to low voltage (converts to the mains power supply setting value), switches to the mains bypass power supply state, and starts battery charging (charging according to the charging priority), and the battery is charged to the battery voltage and switches to the inverter power supply setting value. Can be converted back to inverter output.

##### 3.2 With PV and no mains electricity

- PV power gives priority to powering the load, and the excess energy is used to charge the battery.
- If the PV power energy is insufficient for load use, the battery will be discharged to replenish it.
- PV power give priority to providing load energy.

If the PV power energy is insufficient, the battery discharges to supplement the load power supply. (The battery is discharged to low voltage protection, the inverter switches to standby state, the PV power charges the battery, the battery is charged to the battery low voltage recovery setting value, and the inverter output can be resumed. Or manually press the power button twice, with an interval of 1 to 2 seconds. , can be re-inverter output)

##### 3.3 With mains power and no PV

- Prioritize battery discharge for load use.
- The battery is discharged to low voltage (converts to the commercial power supply setting value), switches to the commercial power bypass power supply state, and starts battery charging (charging according to the charging priority). The battery is charged to the battery voltage and switches to the inverter power supply setting value. Can be converted back to inverter output.
- When the mains power is lost, the battery will be discharged. When the battery is discharged to low voltage, it will be switched to standby.

## B. Hybrid mode

### 1. Mains power priority

Mains power and PV power provide power to the load at the same time, and the battery only provides power to the load when the mains power is unavailable; PV power are given priority to charge the battery, and when there is excess energy, it will be used to power the load.

#### 1.1 There is PV and mains electricity

- a. Priority is given to the mains to provide load energy; PV power charge the battery.
- b. When the PV power energy is insufficient, the mains charges the battery to make up for the remaining charging current.
- c. The battery is fully charged or the PV power generation is greater than the required charging power, and the excess PV energy is used for the load. (The remaining PV power is greater than the load power, and the load energy is all provided by PV and no mains energy is consumed)
- d. The battery is fully charged or the PV power generation is greater than the required charging power, and the excess PV energy is used for the load. (The remaining PV power is less than the load power, and the part insufficient for load use is supplemented by mains power)

#### 1.2 With PV, no mains power

- a. PV power give priority to providing load energy, and the remaining energy is used to charge the battery.
- b. PV power give priority to providing load energy. If the PV power energy is insufficient, the battery discharges to supplement the load power supply.
- c. PV power give priority to providing load energy. If the PV power energy is insufficient, the battery discharges to supplement the load power supply. (The battery is discharged to low voltage protection, the inverter switches to standby state, the PV power charges the battery, the battery is charged to the battery low voltage recovery setting value, and the inverter output can be resumed. Or manually press the power button twice, with an interval of 1 to 2 seconds. , can be re-inverter output)

#### 1.3 With mains power, no PV

- a. The mains power supplies power to the load and charges the battery according to the charging setting value.
- b. If the mains power is lost, the battery will be discharged. When the battery is discharged to low voltage, it will be switched to standby.

### 2. PV power priority

Mains power and PV power provide power to the load at the same time, and the battery only provides power to the load when the mains power is unavailable; PV power is given priority to power the load, and when there is excess energy, it will be used to charge the battery.

#### 2.1 There is PV and mains electricity

- a. PV power energy is provided to the load first, and the excess energy is used to charge the battery.
- b. If the PV power energy is insufficient, the charging current will be reduced to 0.

If loading continues, the mains power will supplement the insufficient energy. (That is, photovoltaic + mains power are loaded at the same time)

#### 2.2 With PV and no mains electricity

- a. PV power energy is provided to the load first, and the excess energy is used to charge the battery.
- b. If the PV power energy is insufficient for the load, the battery will be discharged to supplement it.
- c. PV power give priority to providing load energy. If the photovoltaic energy is insufficient, the battery discharges to supplement the load power supply. (The battery is discharged to low voltage protection, the inverter switches to standby state, the photovoltaic charges the battery, the battery is charged to the battery low voltage recovery setting value, and the inverter output can be resumed. Or manually press the power button twice, with an interval of 1 to 2 seconds. , can be re-inverter output)

#### 2.3 With mains power and no PV

- a. The mains power supplies power to the load and charges the battery according to the charging setting value.
- b. If the mains power is lost, the battery will be discharged. When the battery is discharged to low voltage, it will be switched to standby.

### 3. Battery priority (off-grid operation)

PV power will give priority to supplying power to the load.

If the photovoltaics are insufficient or unavailable, batteries will be used as a supplement to provide power to the load. When the battery discharge voltage reaches the set value, it will switch to the mains to supply power to the load.

#### 3.1 There is PV and mains electricity

- a. The inverter works in the inverter state, PV energy gives priority to powering the load, and excess energy charges the battery.
- b. When the PV energy is insufficient for the load, the battery is discharged to supplement, and the PV and battery supply power to the load at the same time.
- c. The battery is discharged to low voltage (converts to the mains power supply setting value), switches to the mains bypass power supply state, and starts battery charging (charging according to the charging priority), and the battery is charged to the battery voltage and switches to the inverter power supply setting value. Can be converted back to inverter output.

#### 3.2 With PV and no mains electricity

- a. PV gives priority to powering the load, and the excess energy is used to charge the battery.
- b. If the PV energy is insufficient for load use, the battery will be discharged to replenish it.
- c. PV power give priority to providing load energy. If the PV power energy is insufficient, the battery discharges to supplement the load power supply. (The battery is discharged to low voltage protection, the inverter switches to standby state, the photovoltaic charges the battery, the battery is charged to the battery low voltage recovery setting value, and the inverter output can be resumed. Or manually press the power button twice, with an interval of 1 to 2 seconds. , can be re-inverter output)

#### 3.3 With mains power and no PV

- a. Prioritize battery discharge for load use.
- c. The battery is discharged to low voltage (converts to the commercial power supply setting value), switches to the commercial power bypass power supply state, and starts battery charging (charging according to the charging priority), and the battery charges to the battery voltage and switches to the inverter power supply setting value. Can be converted back to inverter output.
- c. If the mains power is lost, the battery will be discharged. When the battery is discharged to low voltage, it will be switched to standby.

## C. Off-grid mode

### 1. Mains power priority

Mains power supplies priority to the load (bypass), and PV power only charge the battery (PV energy cannot meet the charging set value, and mains power supplies supplementary charging). However, when mains power is unavailable, the battery inverter works (PV + battery supplies power to the load). , the volts will give priority to supplying electric energy to the load. If the photovoltaic has excess energy, the battery will be charged. If the PV is insufficient or cannot be used, the battery will be used as a supplement to provide power to the load).

- a. Priority is given to the mains to provide load energy; PV power charge the battery.
- b. When the PV power energy is insufficient, the mains charges the battery to make up for the remaining charging current.
- c. When the mains power is unavailable, it switches to battery inversion work (photovoltaic + battery supplies power to the load, the PV power will give priority to supplying power to the load, and if the PV power has excess energy, it will charge the battery.)
- d. Mains power is unavailable. If the PV power power supply is insufficient for the load, the battery will be used as a supplement to provide power for the load.
- e. The mains power supplies power to the load and charges the battery according to the charging setting value.
- f. When the mains power is lost, the battery will be discharged. When the battery is discharged to low voltage, it will be switched to standby.

### 2. Photovoltaic priority/off-grid mode.

**Under normal circumstances, do not select PV priority as the output priority.**

PV power will give priority to supplying power to the load. If the photovoltaic has excess energy, it will charge the battery. If the PV is insufficient or unavailable, the battery will be used as a supplement to provide power to the load. When the battery discharge voltage reaches the set value, it will switch to the mains to supply power to the load.

- a. PV energy is provided to the load first, and the excess energy is used to charge the battery.
- b. If the PV energy is not enough for the load, the battery should be discharged to replenish it.
- c. The battery is discharged to low voltage (transferred to the commercial power setting value) and transferred to the commercial power bypass for load. (Photovoltaic charges the battery)
- d. When the battery is charged to low voltage and restored to the set value, it will not turn into the battery inversion state. Only when the mains fails will the system switch back to battery inverter power supply.

### 3. Battery priority

PV power will give priority to supplying power to the load. If the PV power are insufficient or unavailable, batteries will be used as a supplement to provide power to the load. When the battery discharge voltage reaches the set value, it will switch to the mains to supply power to the load.

### D. No battery operation mode

If there is no battery configured in the system, the inverter needs to be set to bNC without battery (setting item A11).

**Note:** After selecting the battery-less mode, the output priority cannot be set to battery output priority, otherwise the inverter will not perform work according to the battery output priority working logic, but will be forced to perform in grid-connected or hybrid mode. (In other modes, battery output is prioritized and operates in off-grid mode)

#### 1. Grid-tie mode:

a. PV solar energy is given priority to load power supply. When the PV power generation is not enough for the load, the mains power is supplemented. When the PV power is greater than the load power, the excess energy is fed to the grid.

b. When the mains power is unavailable, turn to PV inverter to carry the load. If the PV energy is insufficient, the output will be turned off. (Alarm, after more than ten seconds, if the PV voltage is within the range, the output will be restarted)

#### 2. Hybrid mode:

a. PV power energy is given priority to load power supply, and when the PV power generation is not enough for the load, the mains power will be supplemented.

b. When the mains power is unavailable, turn to PV inverter to carry the load. If the PV energy is insufficient, the output will be turned off. (Alarm, after more than ten seconds, if the PV voltage is within the range, the output will be restarted)

#### 3. Off-grid mode:

**(It is not recommended to set to off-grid mode, because in this case, if the PV power is insufficient, the output will be unstable)**

a. The PV inverter is loaded. If the PV energy is insufficient, the output will be turned off. (Alarm, after more than ten seconds, if the PV voltage is within the range, the output will be restarted) In this mode, only the PV can be turned on and loaded, and the mains power is invalid.

## 7. Maintenance

1) The inverter just needs the minimum maintenance. And life of Pb(battery) can be preserved by frequent charge.

2) Batteries should be charged for every three months if the inverter is long-term unused.

3) Lifespan of battery normally lasts for three to five years. It should be replaced in advance if any battery is found in poor state. And the replacement shall be operated by the professional.

4) Batteries should be wholly replaced by the instruction of the supplier.

5) For every three months, batteries should be discharged (until the inverter shuts down) and recharged. Every charge (by standard inverter) should last at least for 12 hours.

6) Among high temperature area, batteries should be discharged and recharged forevery two months. Every charge (by standard inverter) should last at least for 12 hours.

#### Note:

- Please shut down the inverter , then disconnect AC input and PV input before replacing batteries.
- Please do not wear metal jewelry such as ring or watch.
- Please use screwdriver with insulated handle and avoid to place tools or metal objects on batteries.
- Please avoid short circuit or reverse connection.

#### Warning:

- Battery must not be put in the fire, which may cause explosion.
- Shall not open or damage the battery. Electrolyte released will cause harm to eyes and skin and even intoxication.

#### Assembly of dust filter

As shown in the picture, remove the 2 screws fixing the dust filter cover on the left and right sides. Then take off the dust filter cover and dust filter to clean the dust filter. After cleaning, install the dust filter and its cover in the order shown in the figure, and then use the 2 removed screws to fix the left and right dust filter covers on the inverter.

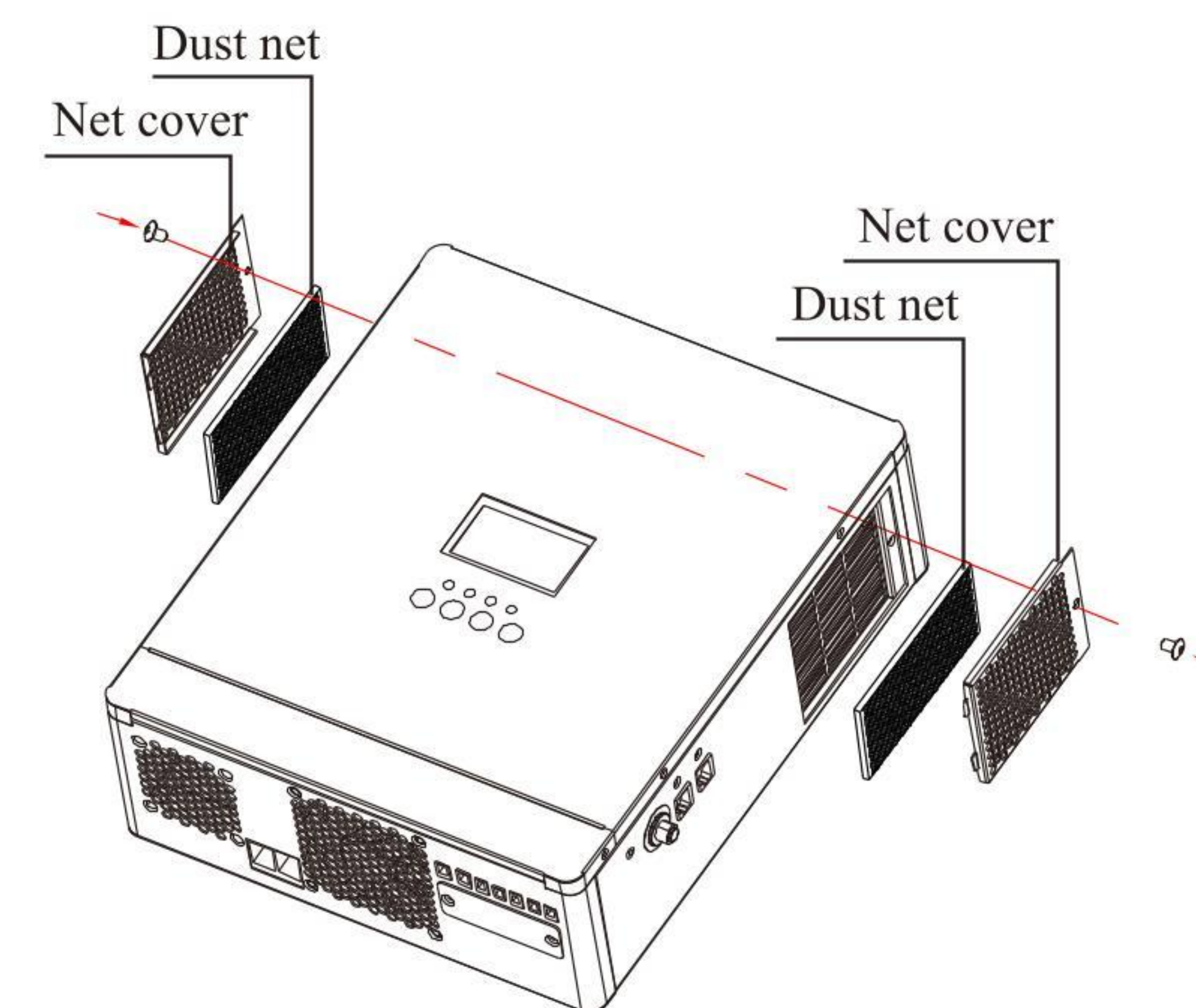

#### Note:

When using the inverter in areas with poor environment, the dust filter is easily blocked by air particles. Please disassemble and clean the dust filter regularly to avoid affecting the air volume and flow rate inside the inverter and triggering the over-temperature protection of components. The Failure will affect power supply usage and the service life of the inverter.

## 8. Technical specification

Model: HFP		33224	43224	63228	83248	103248	123248
PV	Max PV Input Power	5000W	5000W	7000W	4500W*2	6000W*2	6000W*2
	MPPT Tracking Voltage Range	40VDC-450VDC		80VDC-450VDC			
	Rated Voltage	360VDC					
	Max PV Input Voltage Voc (at the lowest temperature)	500VDC					
	Max PV Input Current	18A		27A	18A*2	22A*2	27A*2
	MPPT Tracking Channels (Input Routed )	1			2		
Battery& Charging	Battery Type	Lead-acid Battery/Lithium Battery					
		Custom Battery (Charging and discharging parameters of different types of batteries can be set through the operation board)					
	Rated Battery Voltage	24VDC		48VDC			
	Battery Voltage Range	21~30VDC(default)		42~60VDC(default)			
	Max PV Charging Current	120A	150A	120A	150A	180A	200A
	Max AC Charging Current	80A	100A	80A	100A	120A	140A
	Max Charging Current	120A	150A	120A	150A	180A	200A
	<b>On-Grid Operation</b>						
On-Grid Output (AC)	Rated Output Power	3300W	4300W	6300W	8300W	10.3KW	12.3KW
	Rated Output Voltage	220VAC/230VAC/240VAC					
	Grid Voltage Range	187VAC~264VAC					
	Rated Output Frequency	50Hz/60Hz					
	Frequency Range	47Hz~52Hz(50Hz), 57Hz~62Hz(60Hz)					
	Rated Output Current	14.5A/13.9A /13.3A	19.5A/18.7A /17.9A	28.6A/27.4A /26.2A	37.7A/36.1A /34.6A	46.7A/44.9A /42.9A	55.9A/53.5A /51.3A
	Power Factor	>0.98(Rated Power)					
	<b>Off-Grid Operation</b>						
AC Input	Rated Input Voltage	220V/230V/240V					
	Mains input voltage range	165VAC~280VAC / 120VAC~280VAC(Can be set)					
	Rated Input Frequency	50Hz/60Hz					
	Input Frequency Range	45Hz~55Hz(50Hz), 55Hz~65Hz(60Hz)					
AC Output	Rated Output Power	3300W	4300W	6300W	8300W	10.3KW	12.3KW
	Rated Output Voltage	220V/230V/240V					
	Output Voltage Accuracy	±2%					
	Rated Input Frequency	50Hz/60Hz					
	Output Frequency Accuracy	±1%					
	Output Wave	Pure Sine Wave					

Hybrid Operation (Complementary Mode)							
AC Input	Rated Input Voltage	220V/230V/240V					
	Mains Input Voltage Range	187VAC~264VAC					
	Rated Input Frequency	50Hz/60Hz					
	Input Frequency Range	47Hz~52Hz(50Hz), 57Hz~62Hz(60Hz)					
AC Output	Rated Output Power	3300W	4300W	6300W	8300W	10.3KW	12.3KW
	Rated Voltage Rated	220VAC/230VAC/240VAC					
	Output Current	14.5A/13.9A /13.3A	19.5A/18.7A /17.9A	28.6A/27.4A /26.2A	37.7A/36.1A /34.6A	46.7A/44.9A /42.9A	55.9A/53.5A /51.3A
<b>Regular Parameters</b>							
Maximum Conversion Efficiency (Battery Discharge)		94%(peak value)					
MPPT Tracking Efficiency		≥99.9					
Transfer Time		10ms(Typical value)					
Display		LCD+LED					
Cooling Method		Cooling fan in intelligent control					
Communication		RS485/Dry Contact/Mobile APP(WIFI Monitoring or GPRS monitoring)(Optional)					
Protection Degree		IP20					
Installation		Wall-Mounted					
Protection	Battery low voltage alarm	22VDC(default value)		44VDC(default value)			
	Battery low voltage protection	21VDC(default value)		42VDC(default value)			
	Anti-islanding protection	≤2S					
	Overload power protection	Automatic Protection (battery mode),Circuit Breaker or Insurance (AC mode)					
	Inverter output short circuit protection	Automatic Protection (battery mode),Circuit Breaker or Insurance (AC mode)					
	Temperature protection	>90℃(Shut down output)					
	Environment	Operating temperature	-10℃~50℃				
Storage temperature		-15℃~60℃					
Noise		≤55dB					
Elevation		2000m(More than derating)					
Humidity	0%~95% , (No condensation)						
<b>Dimension and Weight</b>							
Product Size(L*W*Hmm)		325*275*102	365*297*102	390*320*112	515*365*117	535*462*117	630*540*130
Package Size(L*W*Hmm)		400*330*167	440*352*167	465*375*187	600*430*192	615*527*192	715*605*205
N.W.(kg)		6	7	8.5	13	15.5	23.5
G.W.(kg)		6.5	7.5	9.5	15	17.5	25.5

**Note: The above parameters are subject to change without prior notice!**

## 9. RS485 communication interface appendix

### RS485 communication port pin definition

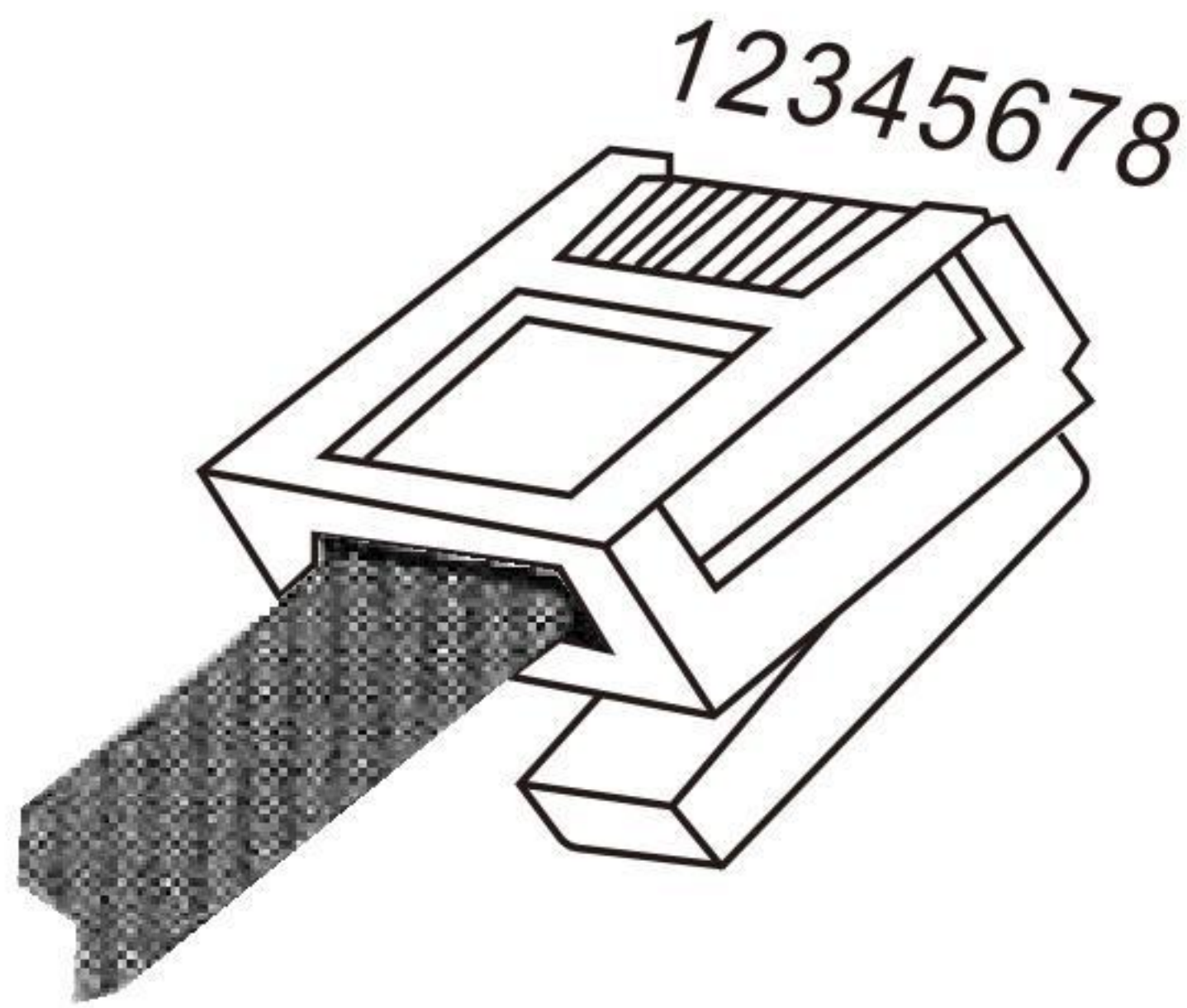
PIN1-----RS485-B	
PIN2-----RS485-A	
PIN3-----NC	
PIN4-----NC	
PIN5-----NC	
PIN6-----NC	
PIN7-----NC	
PIN8-----NC	

**NC: refer to as not connect.**

## 10. WIFI/GPRS communication interface appendix (WIFI/GPRS/4G data collector optional)

WIFI/GPRS/4G data collector access for remote monitoring and control on mobile phones or web pages.

The operating information of the inverter can be uploaded to the server via WiFi/GPRS/4G. Users can choose to use web or APP for monitoring and viewing according to their needs. Users need to register an account and bind the device with a WiFi/GPRS/4G serial number. The serial number of the WiFi/GPRS/4G data collector is affixed to the packaging box and the WiFi/GPRS/4G data collector.

Website: <http://www.dessmonitor.com/#/entry>

Product certificationAPP:Android customers search for “Guangchubao” in the app store. IOS customers search for “Guangchubao” in the APP Store. For detailed instructions on the WIFI/GPRS/4G data collector, please refer to the instruction manual of the WIFI/GPRS/4G data collector.

## Warranty Card

Customer Name: \_\_\_\_\_ Tel.: \_\_\_\_\_

Address: \_\_\_\_\_

Brand: \_\_\_\_\_ Model: \_\_\_\_\_

Serial No.: \_\_\_\_\_ Date of Purchase: \_\_\_\_\_

Bought From: \_\_\_\_\_

Invoice Number: \_\_\_\_\_ Invoice Price: \_\_\_\_\_

### Warranty Instruction

- Please keep this warranty card as proof of maintenance.
- The warranty period is 1 year from the date of purchase.
- During the warranty period, under the condition of normal use and maintenance, if damage caused by the product's own quality, the company will provide free repair and replacement parts after verification.
- The company reserves the right to maintain and interpret all contents.

### Free maintain won't be given under the following circumstance:

- The damage caused by the manipulation that hasn't follow the requests of the manual.
- The product has been repaired, modified by technicians other than our company's, and any internal parts of the product have been replaced by users.
- The product number has been altered or product is inconsistent with the warranty card.
- Damage caused by careless use, penetration of water or other substances into the product.
- Damage caused by accident or natural disaster.

## Certificate

Name: \_\_\_\_\_

Model: \_\_\_\_\_

Inspectors: \_\_\_\_\_

Date: \_\_\_\_\_

Products have been tested qualified by standard and permitted to deliver.